

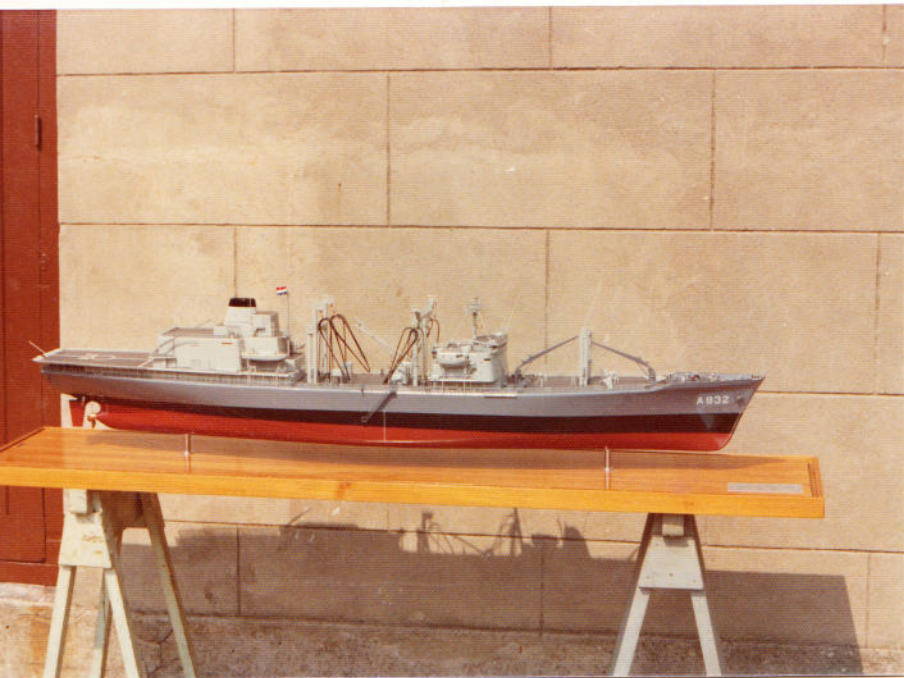

Opname v.
Beekmans
2
Blokkendaal
1973/74







Zwei der besten
Kriegsschiffe

840 mm
Jan 75

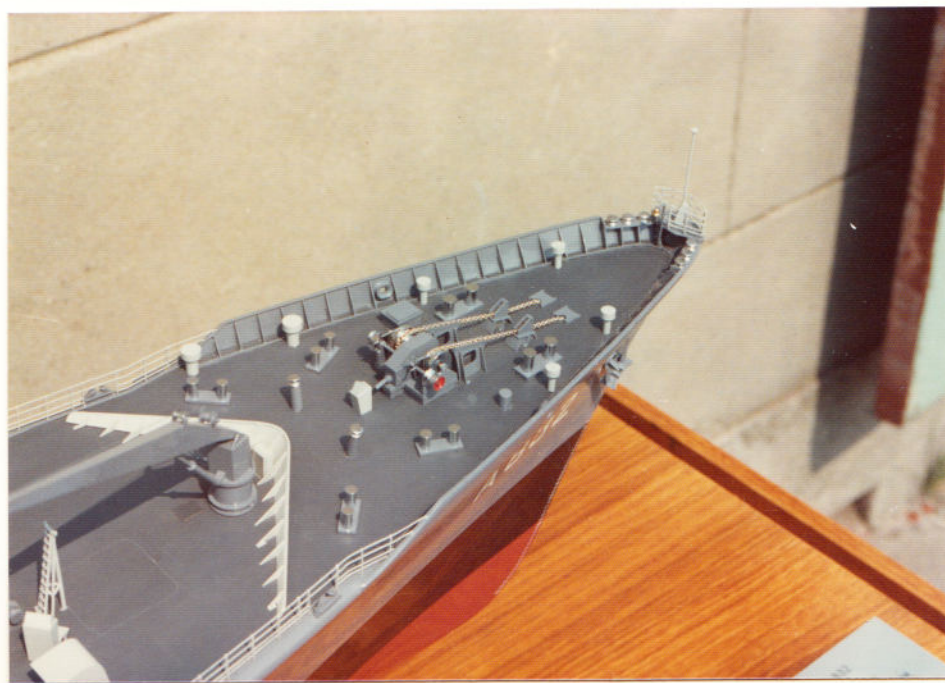

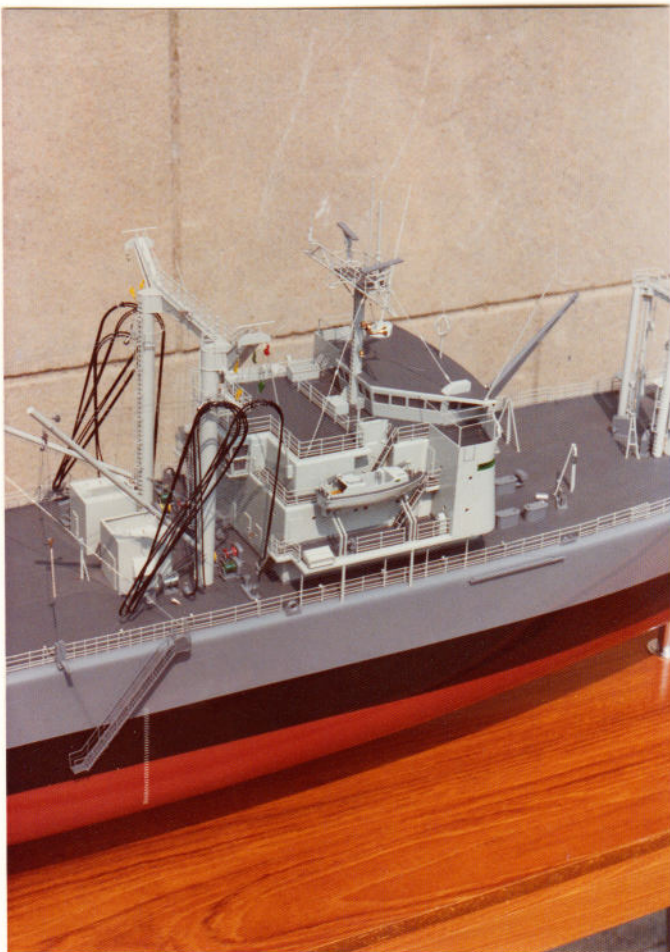
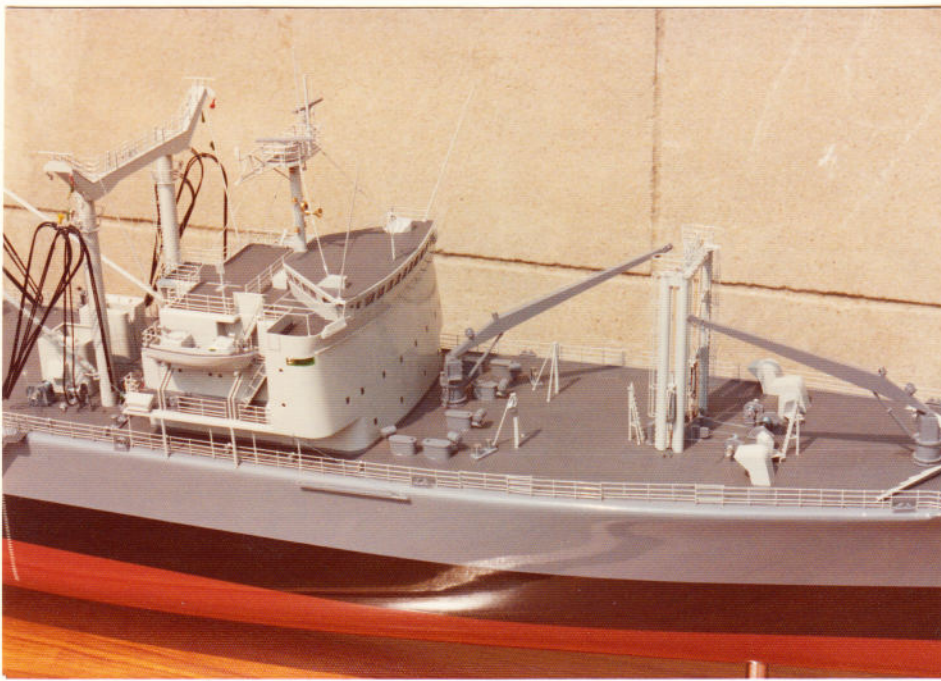

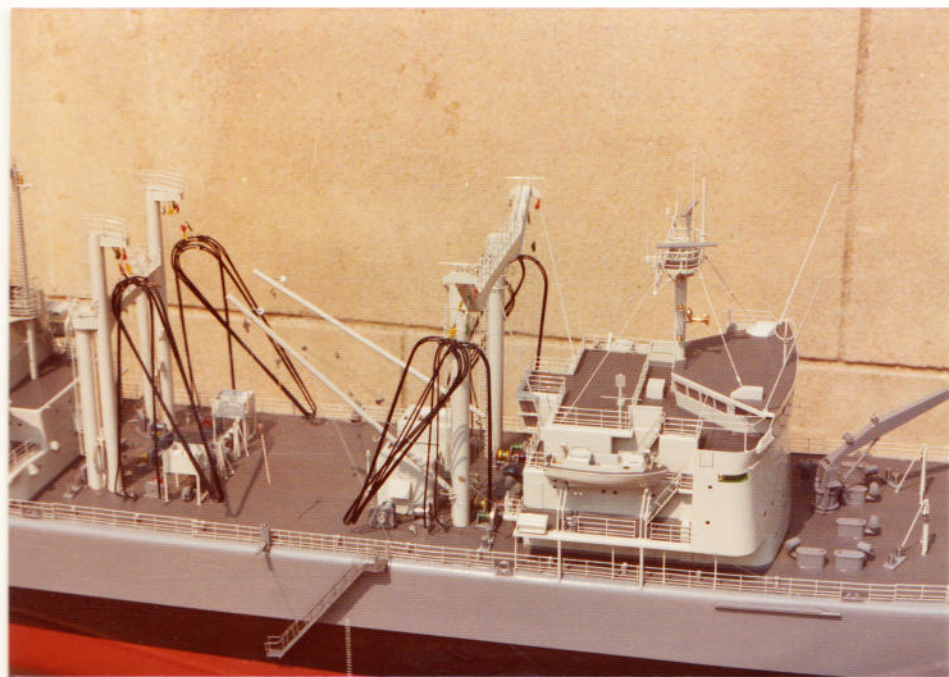
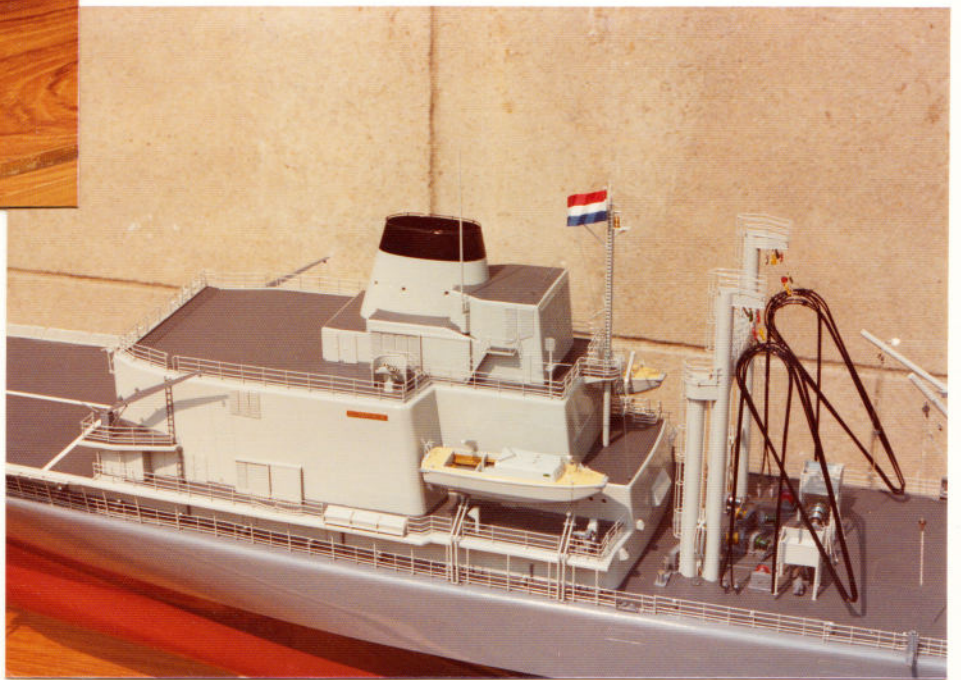

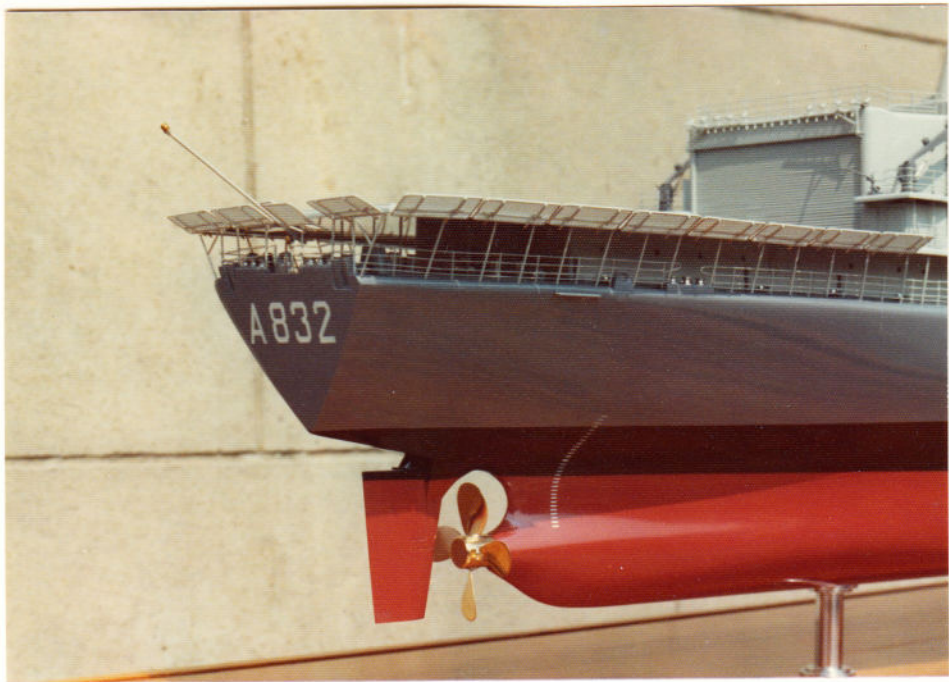
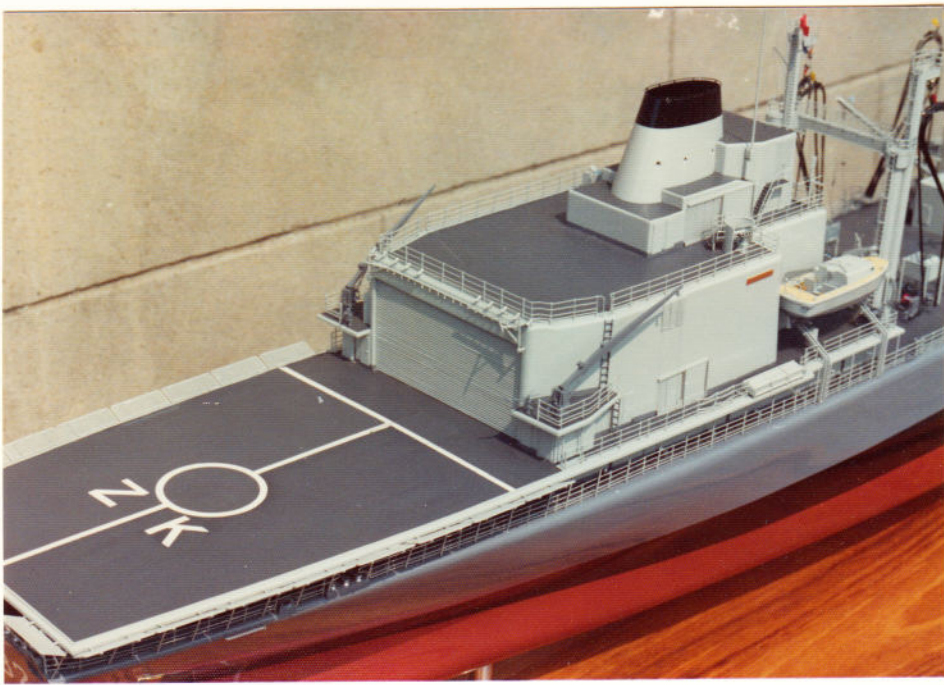

"AMSTERDAM"

SCHELDE

1:100

bevoorradingsschip

166cm

7/4/97

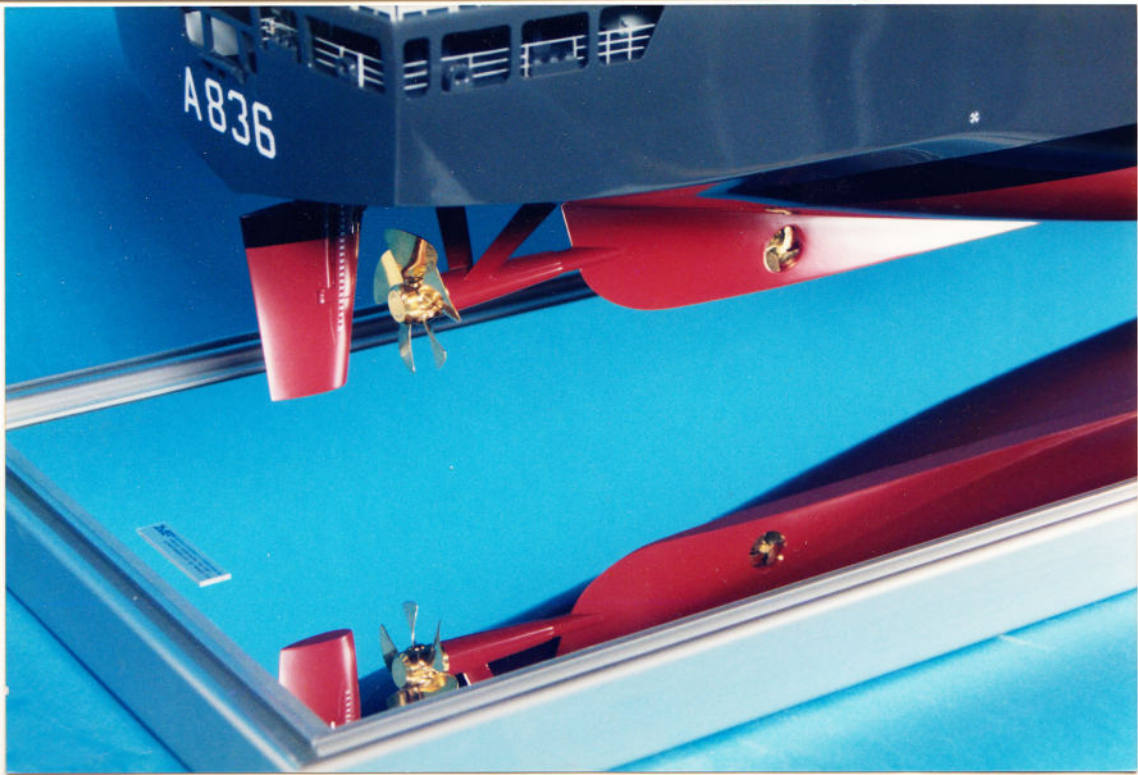

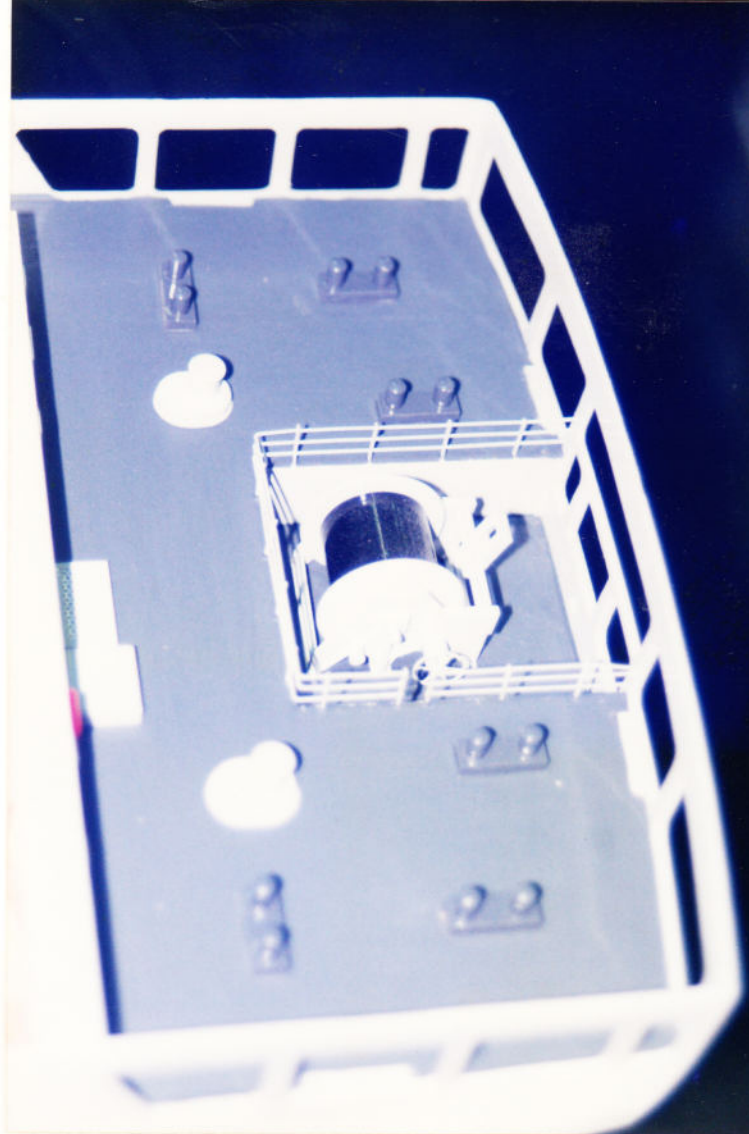
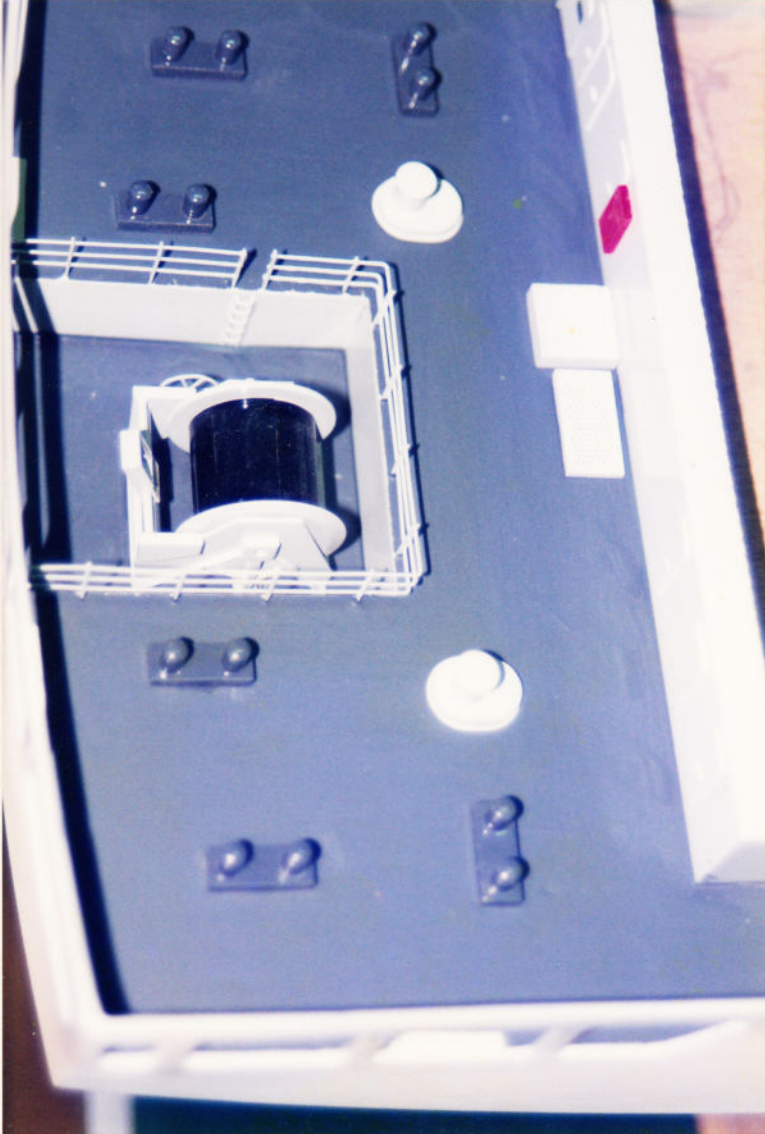







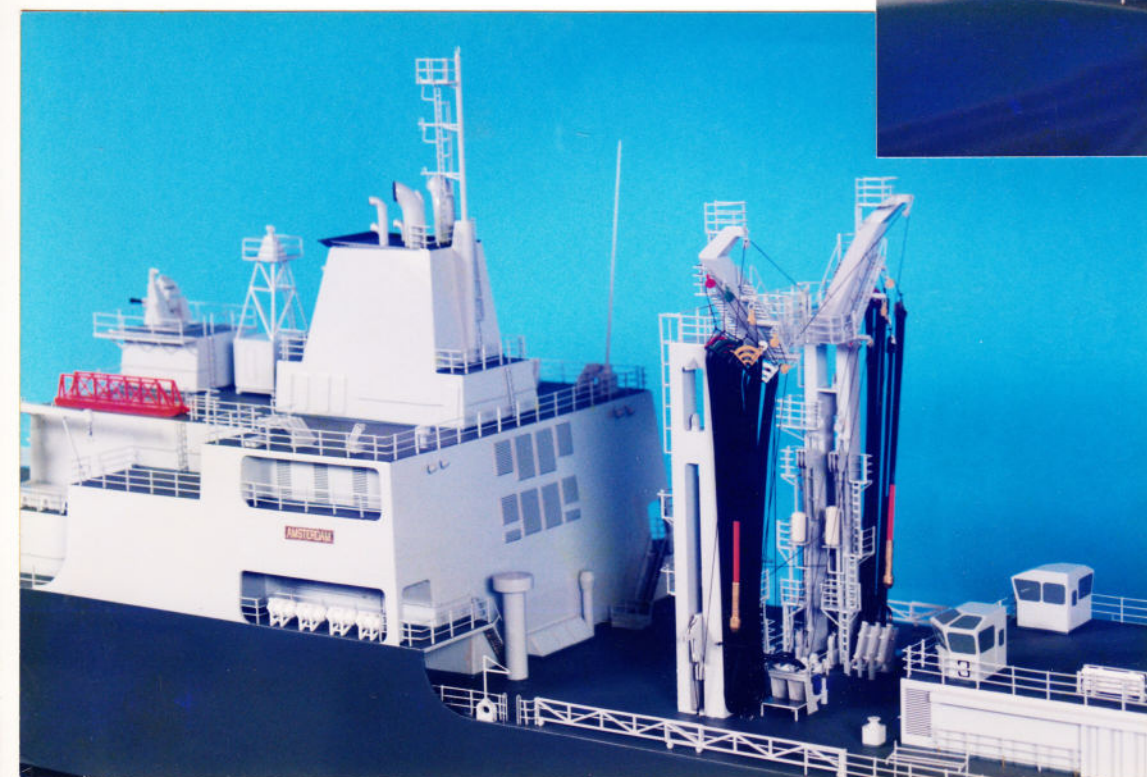

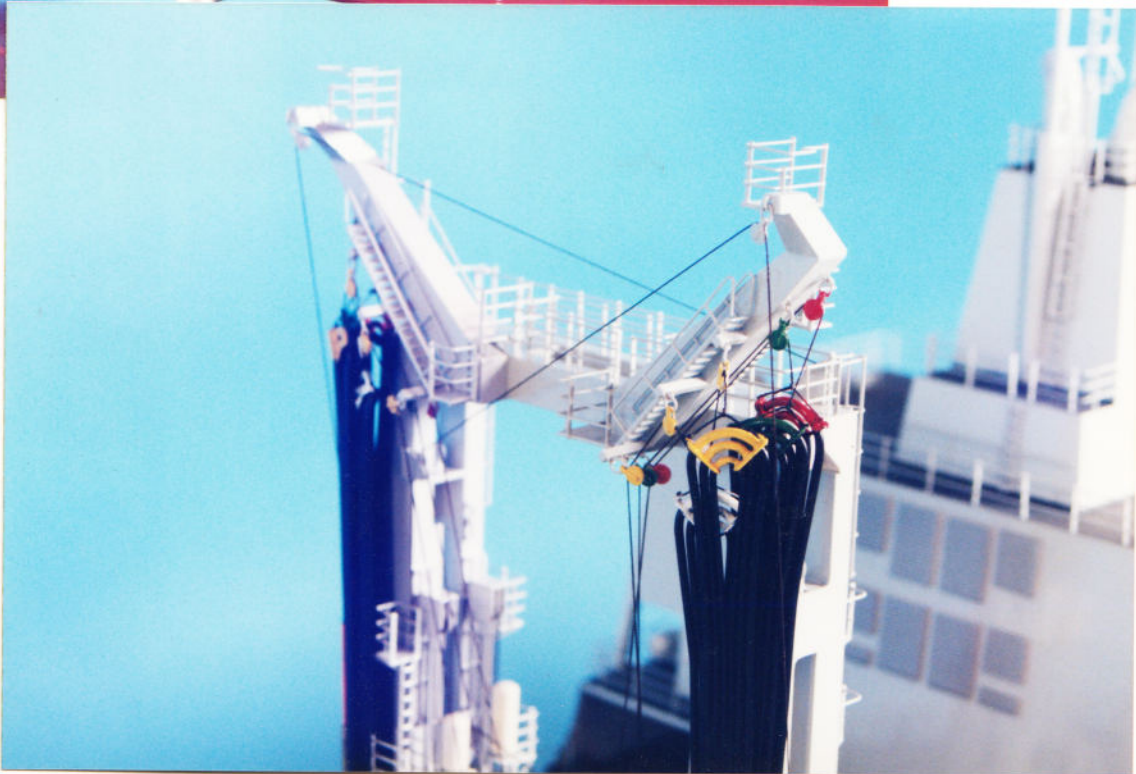

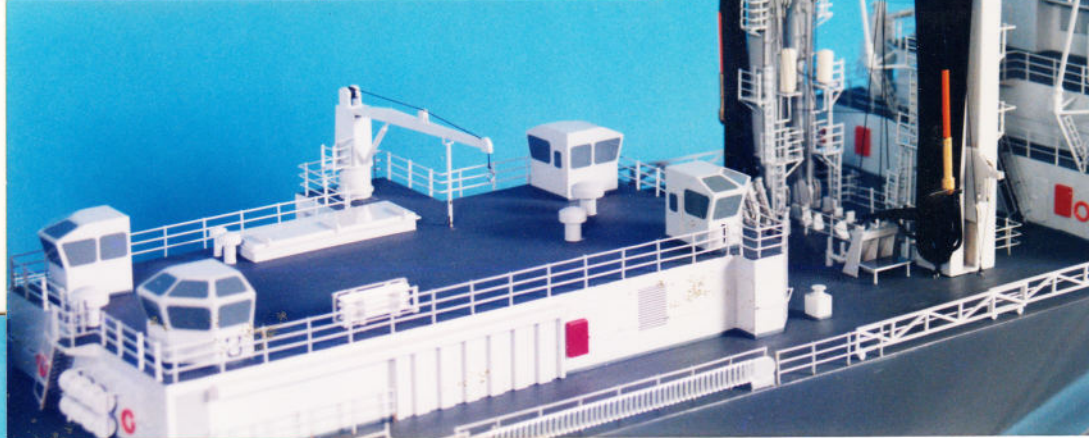
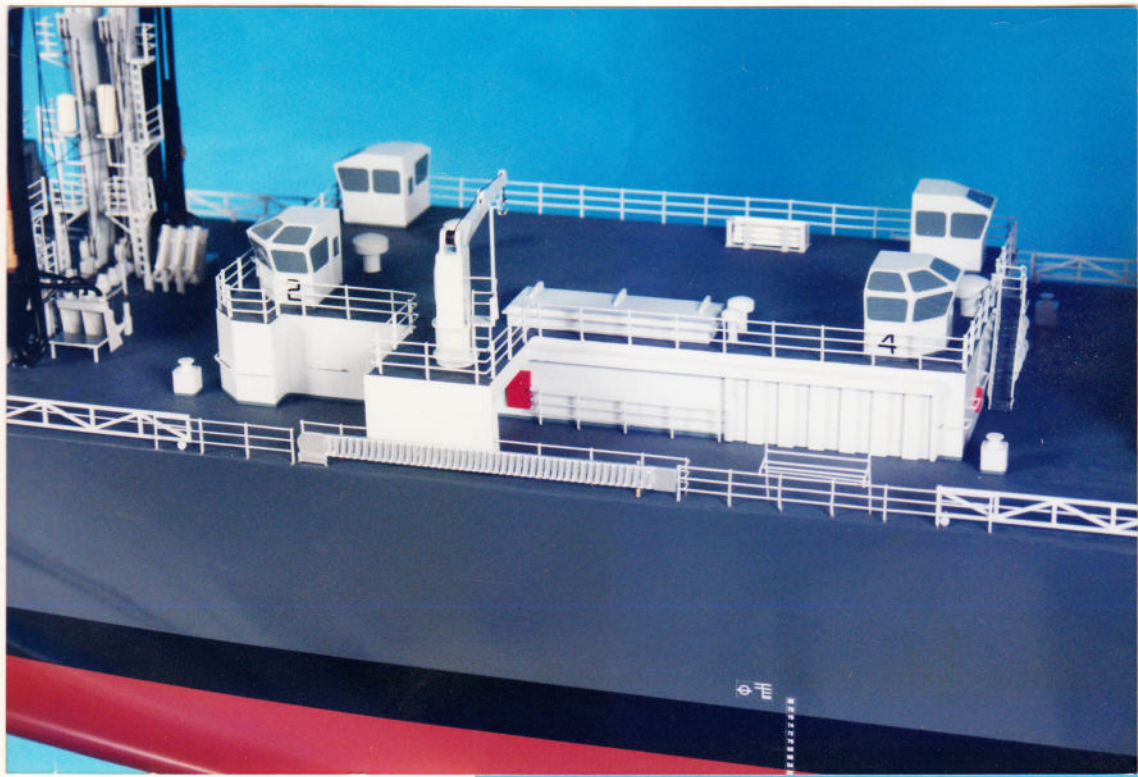



Y. GIESSEN - DEN OORD
H. MENDEKER
"DOKKUM"
1975.

18
2 STUKS 632 uur.
Jan. 1975.







V/d GIESSEN - DENCOED

MYNENJAGER

"DOKKOM"

1:75

OKTOBER 1974

JAN 1975

2 stuks 633 uur

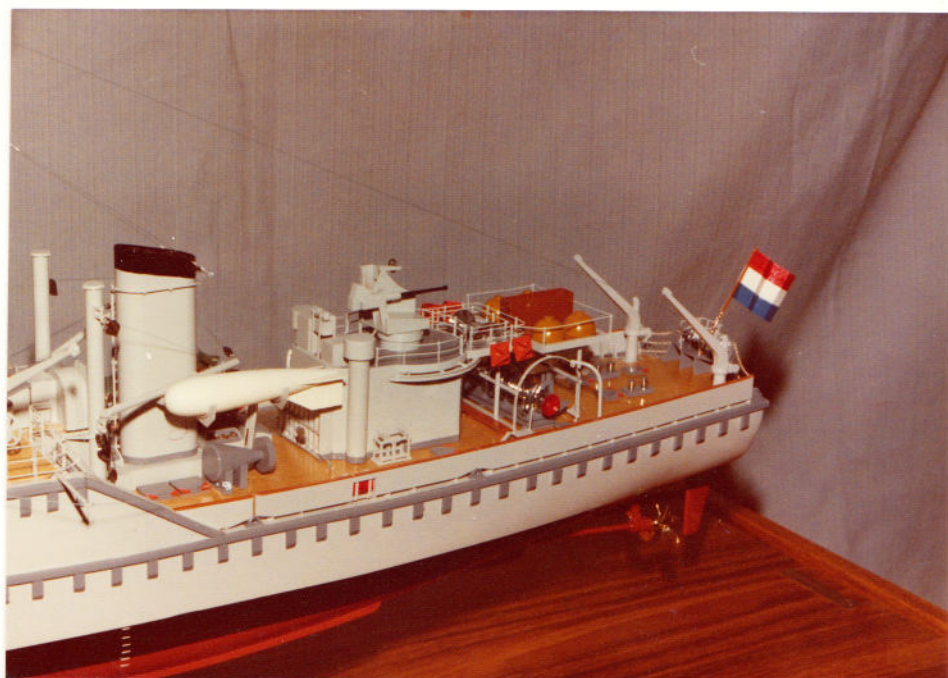

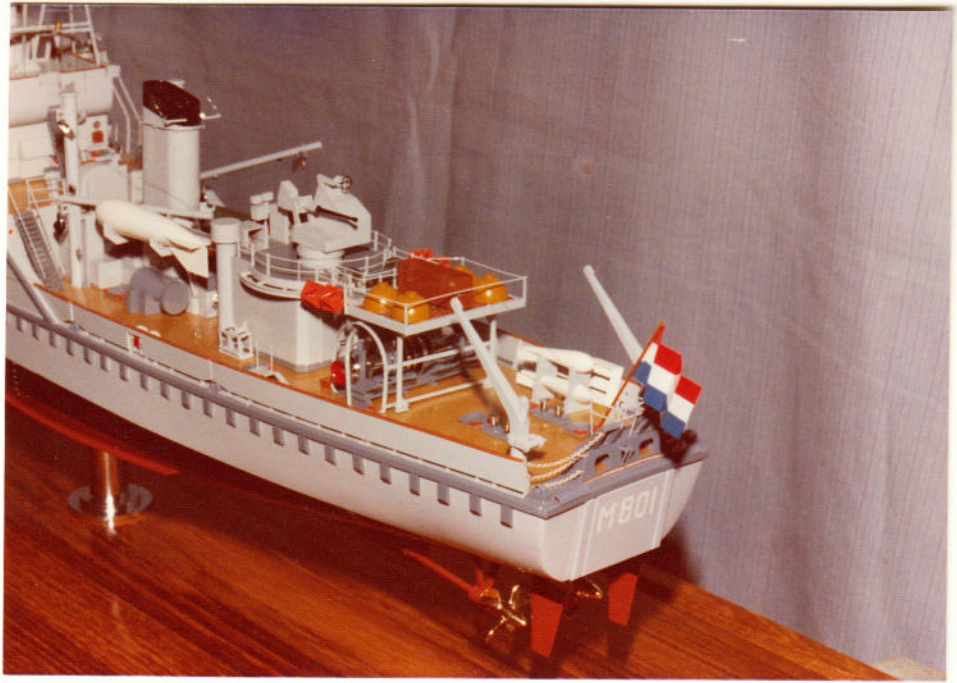



LOODSBOOT

VOYK & ZN.

1:50

21-4-78

761 mm.





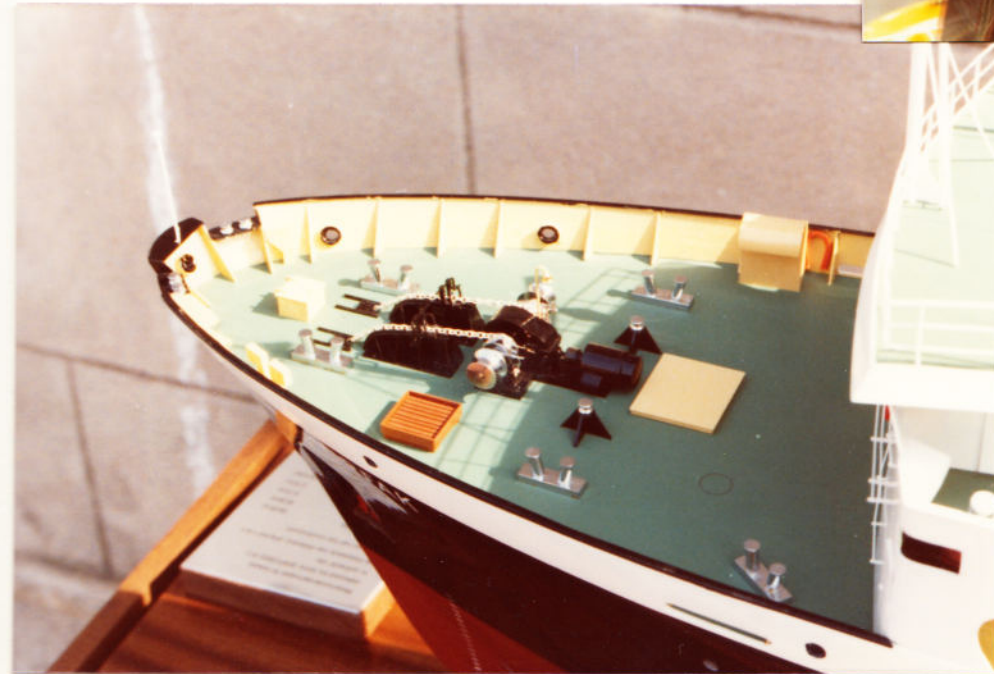
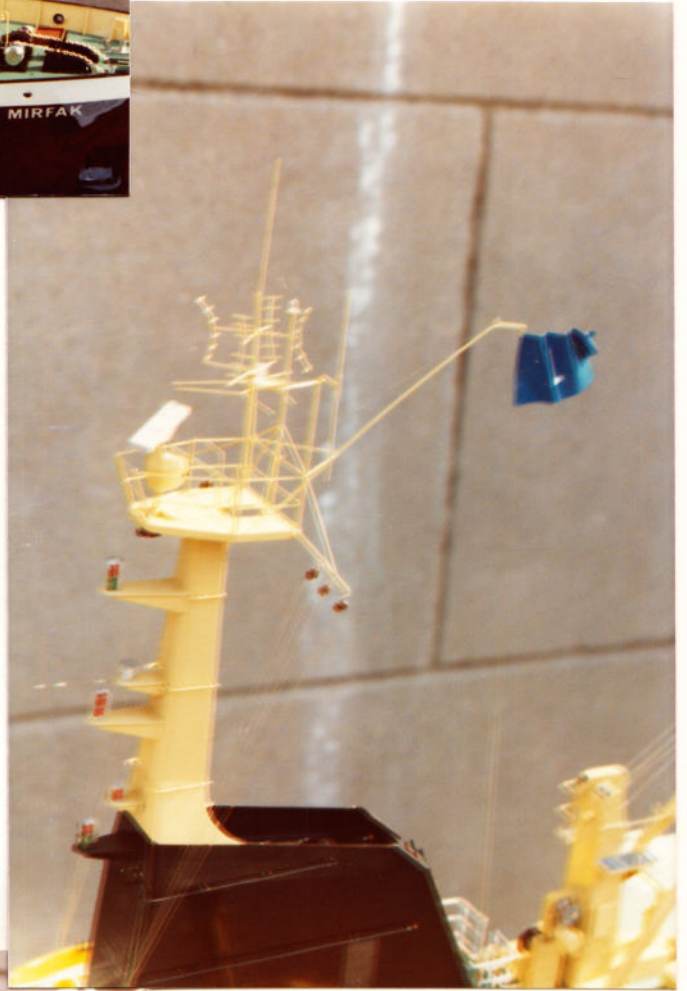



Projekt: MIRFAK
Baujahr: 1970
Länge: 100 m
Breite: 12 m
Tonnage: 1000 t
Antrieb: Diesel
Hersteller: ...



OCEANOGRAPHISCH BN. 612
OPNEMINGSVAARTUIG

"TYDEMAN"

2x

1:100

17-12-77

MERWEDE

~~970 uur.~~

totaal.
970 uur.

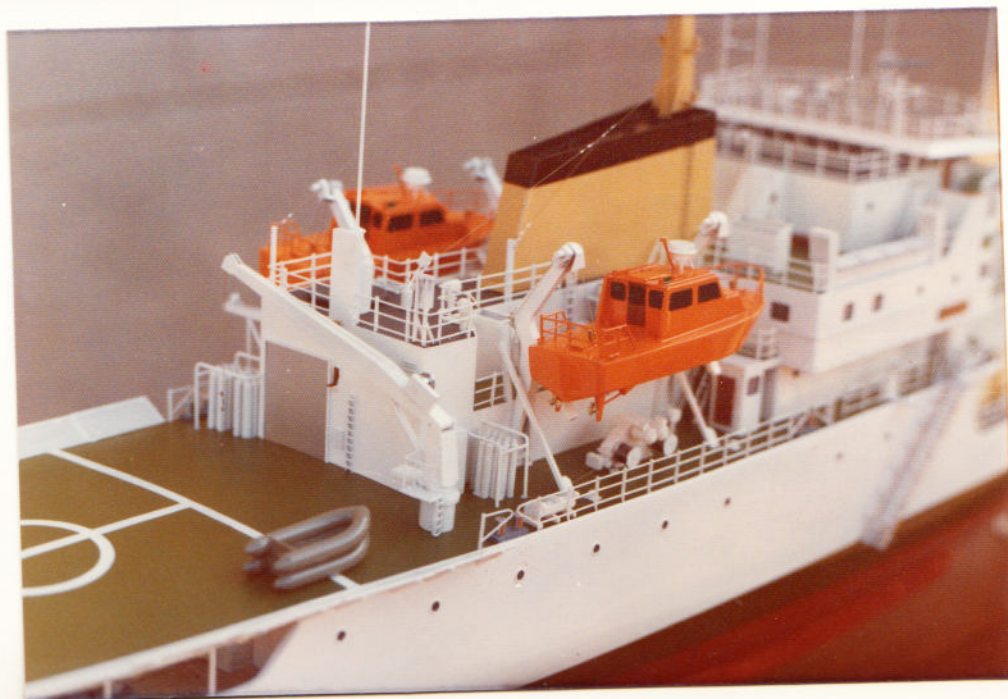



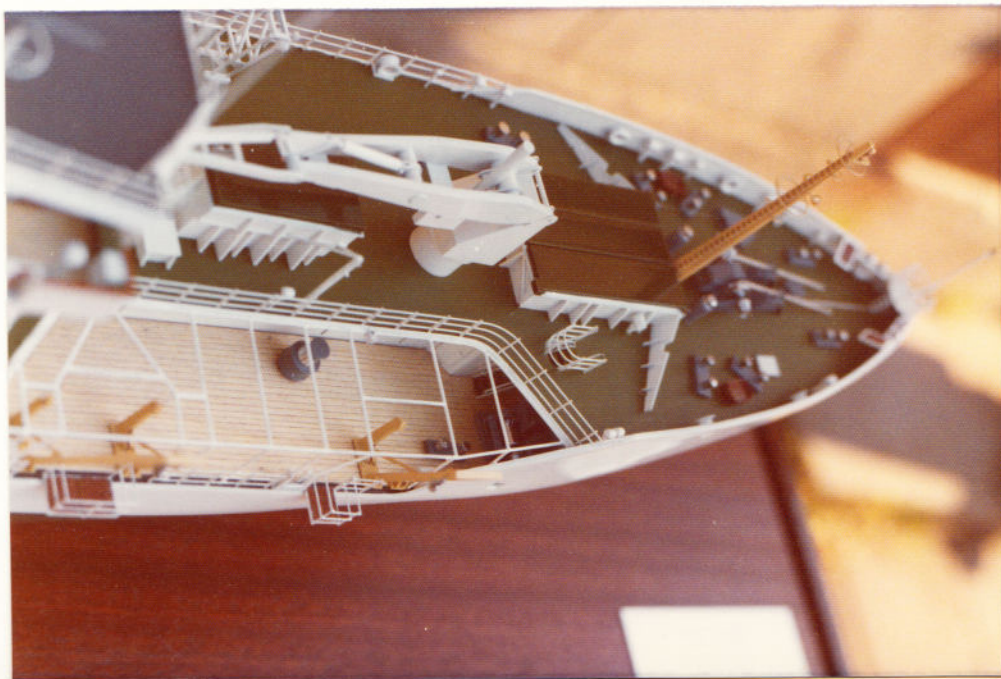





M. Fregat "Karel Doorman"

Kon. Marine

2x 1:100

(incl. tafel en lijst).

1^e 18-4-88

2^e 10-5-88

Totaal: 880 uur.

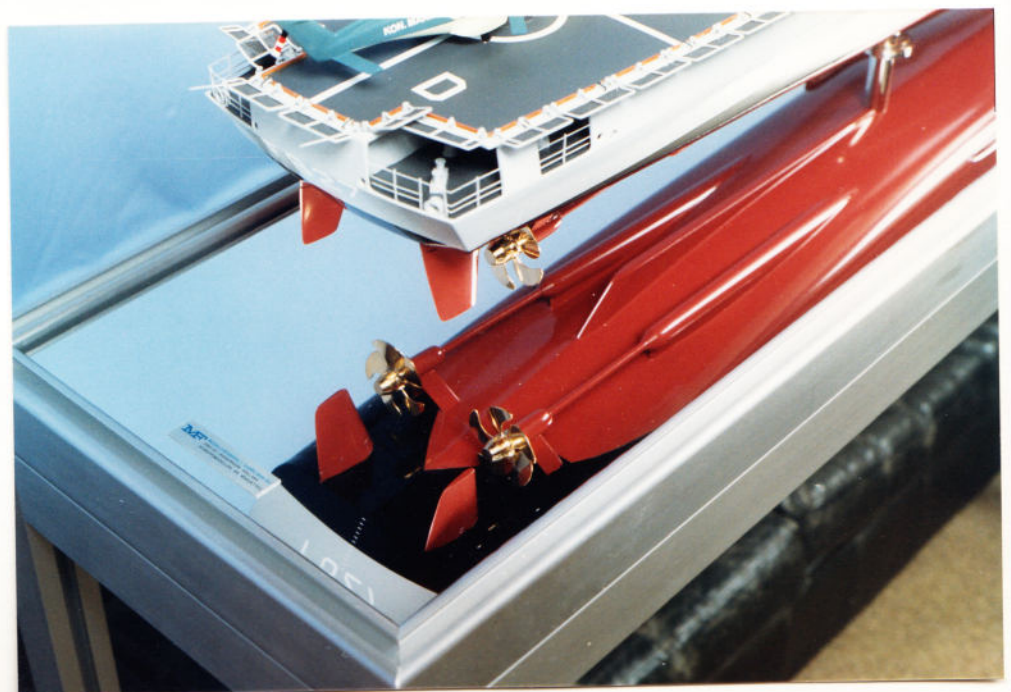





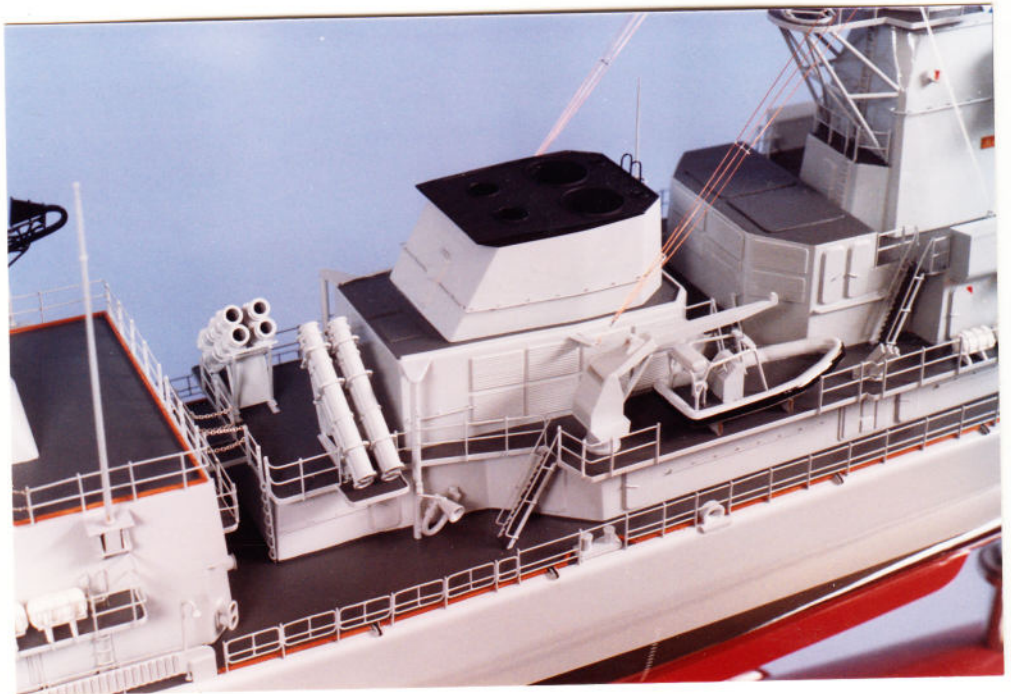
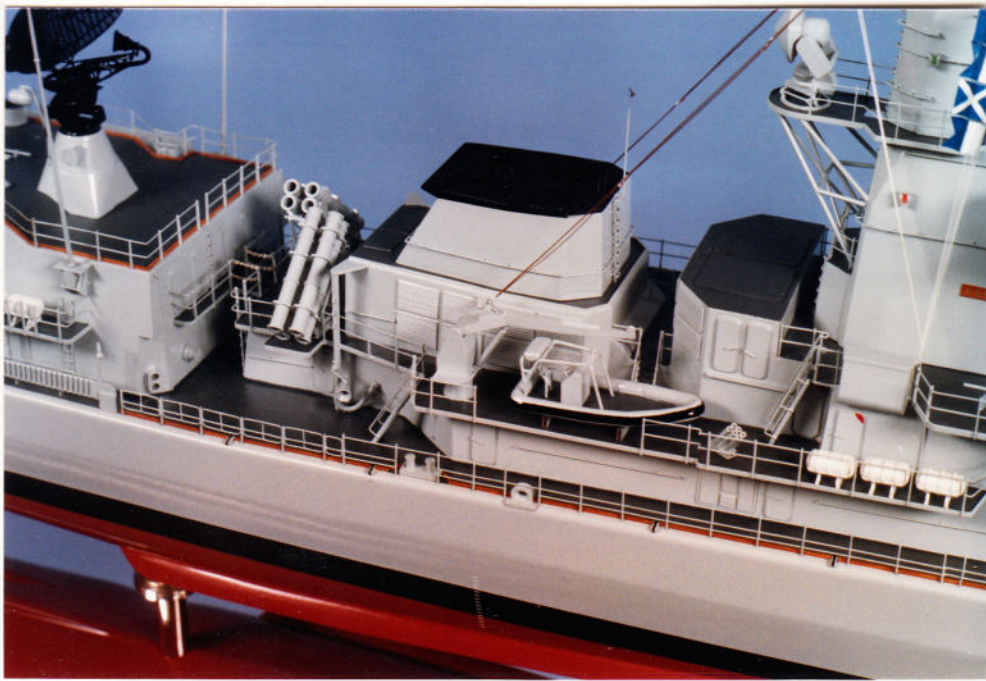

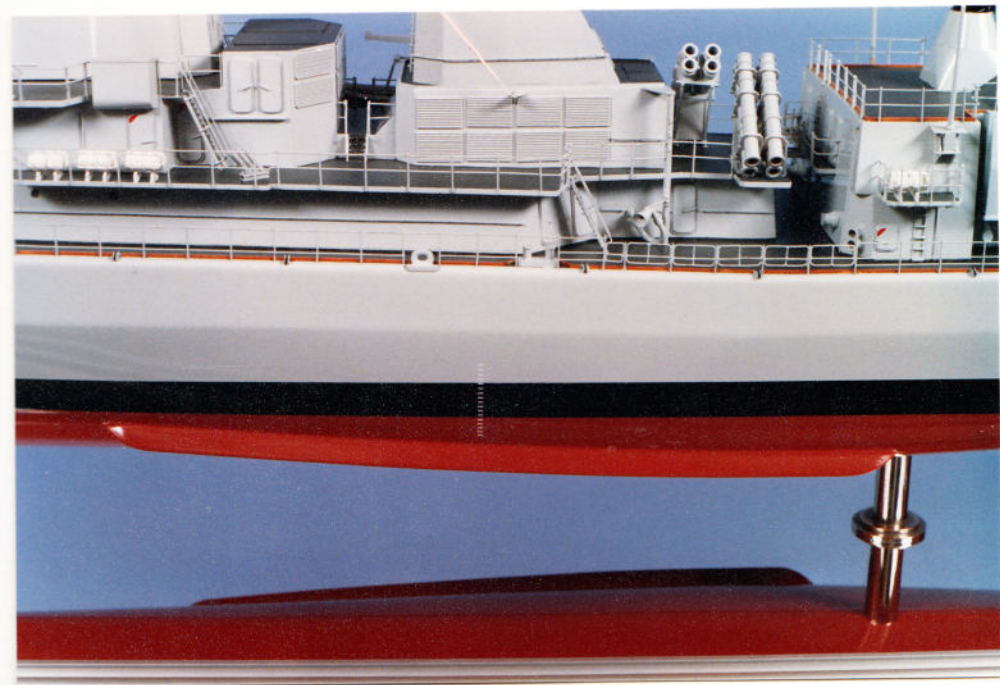





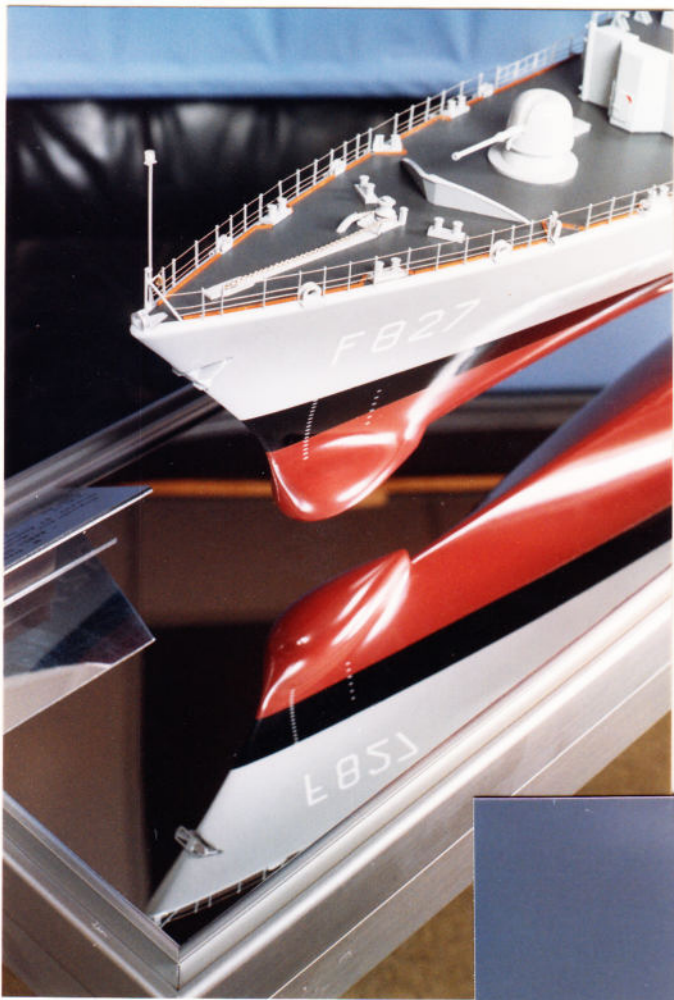



betrandingen 2^e model. 1. geel helicopter.
heli markering
bordet onder radar.
zwarte uitlaten
kippetrap op dek.
scenewerk by reddingstrommels



Seopterwork by vedding-tromuets

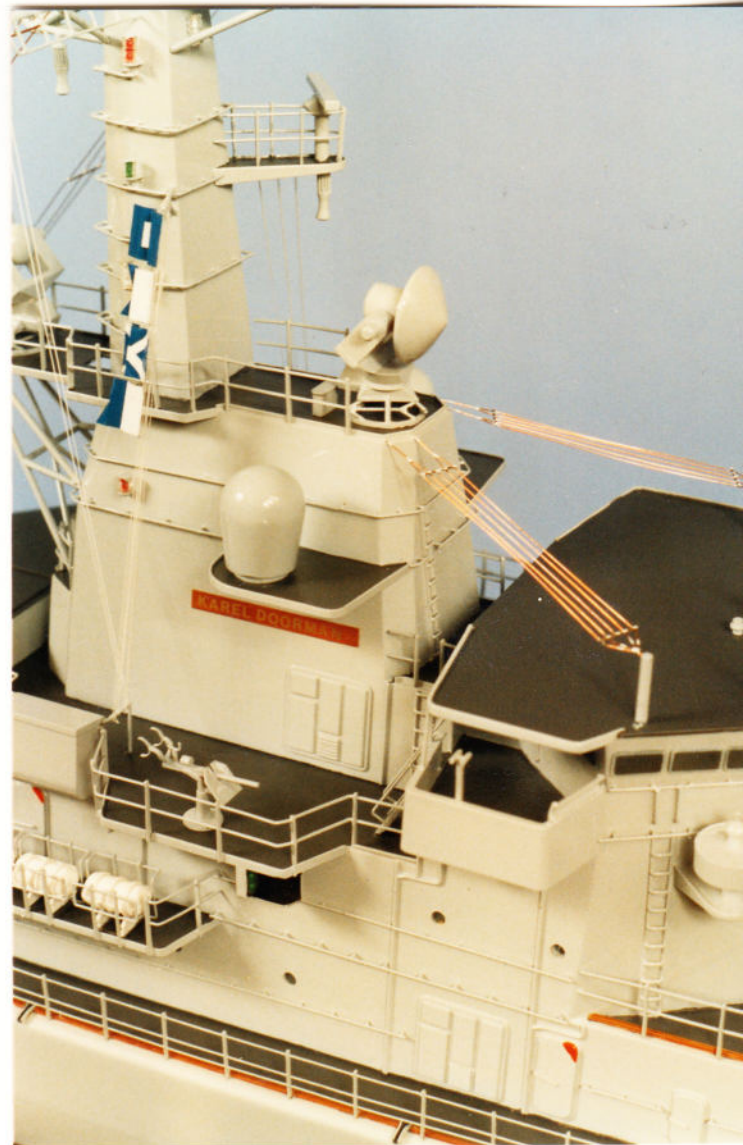

geen strepen op top radar.
andere sloep davit.
wijziging scepterwerk by sloep.

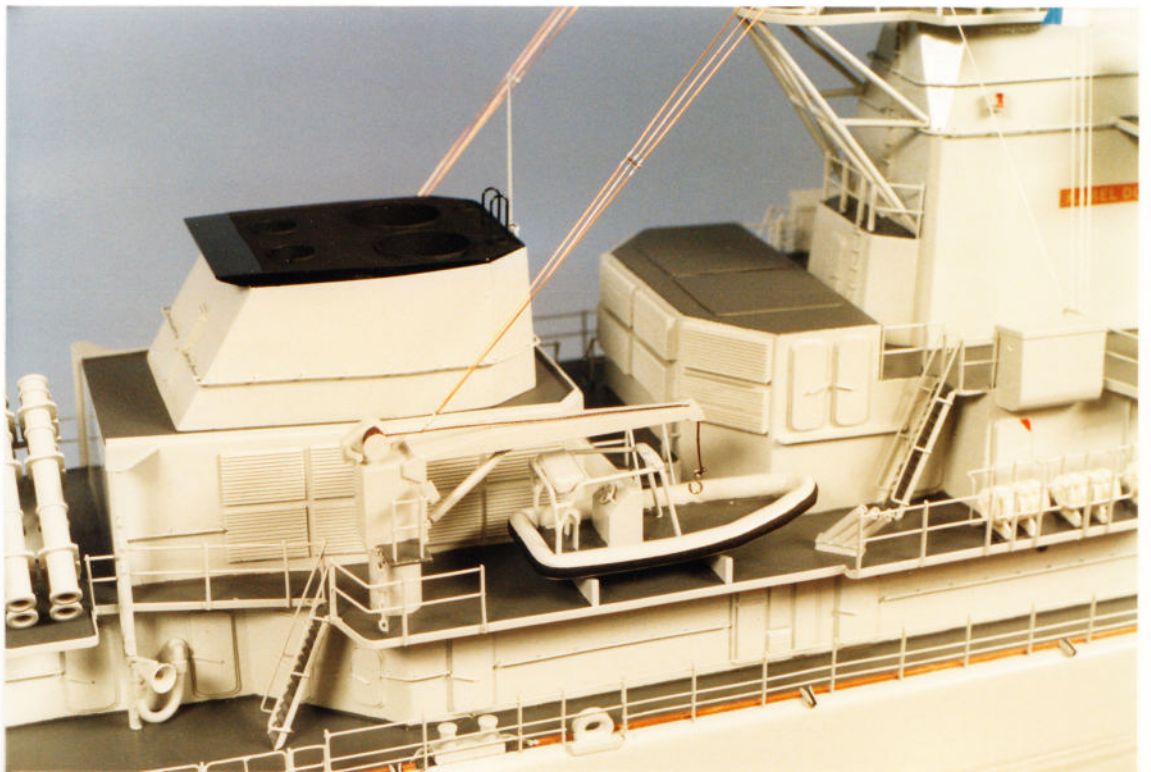

VAN RIETSCHOTEN & HOUWENS
1:100

BEWEEGBARE MODEL
VOOR WERKING STABILISER

10/8/90

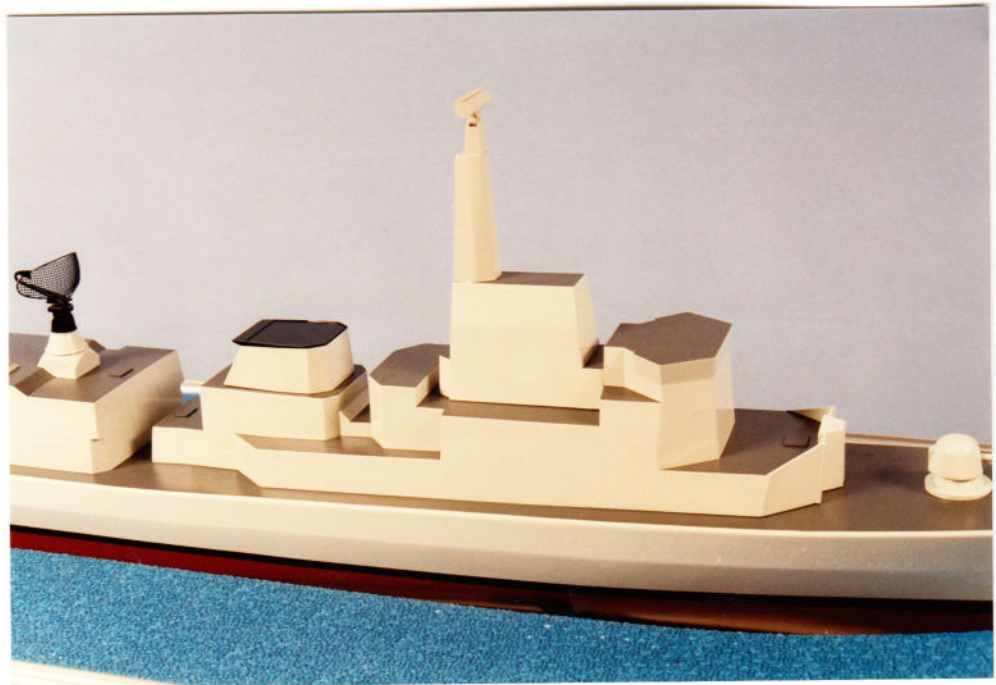
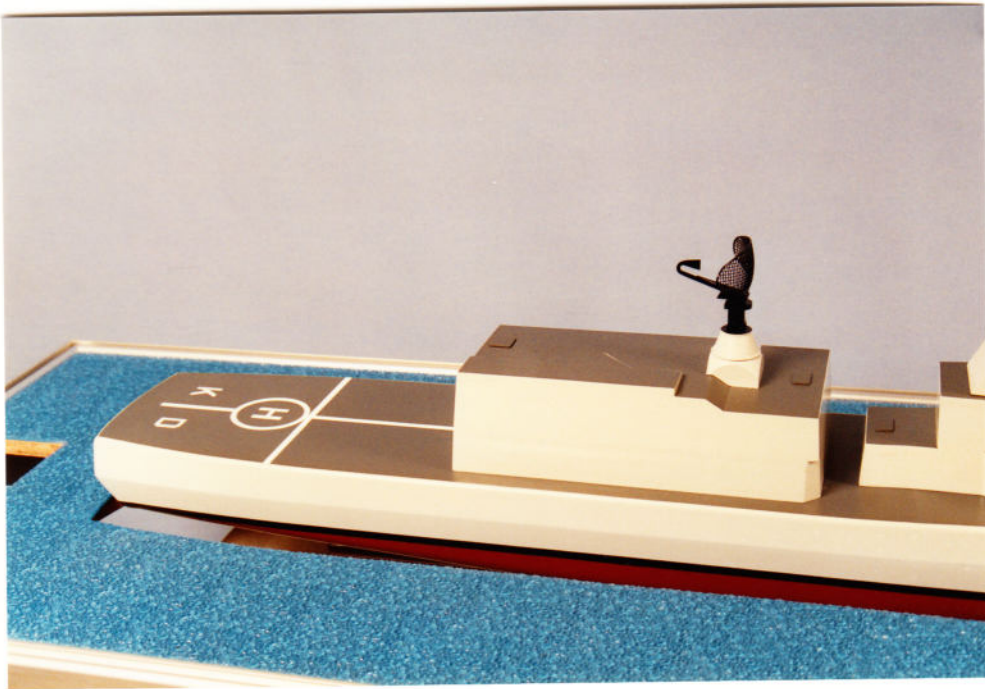
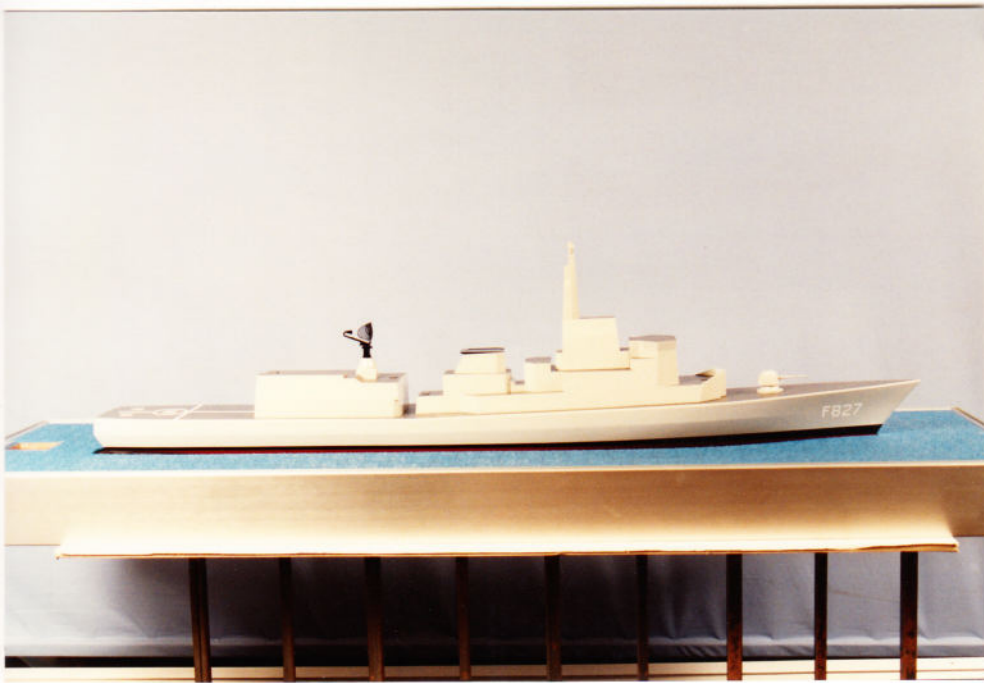





SCHELDE 2
+ HSA 1

LCF

1:100

1^o off. schelde 6/2

2^o " " 4/2

3^o " H.S.A. 13/6

tot. 771 mm.

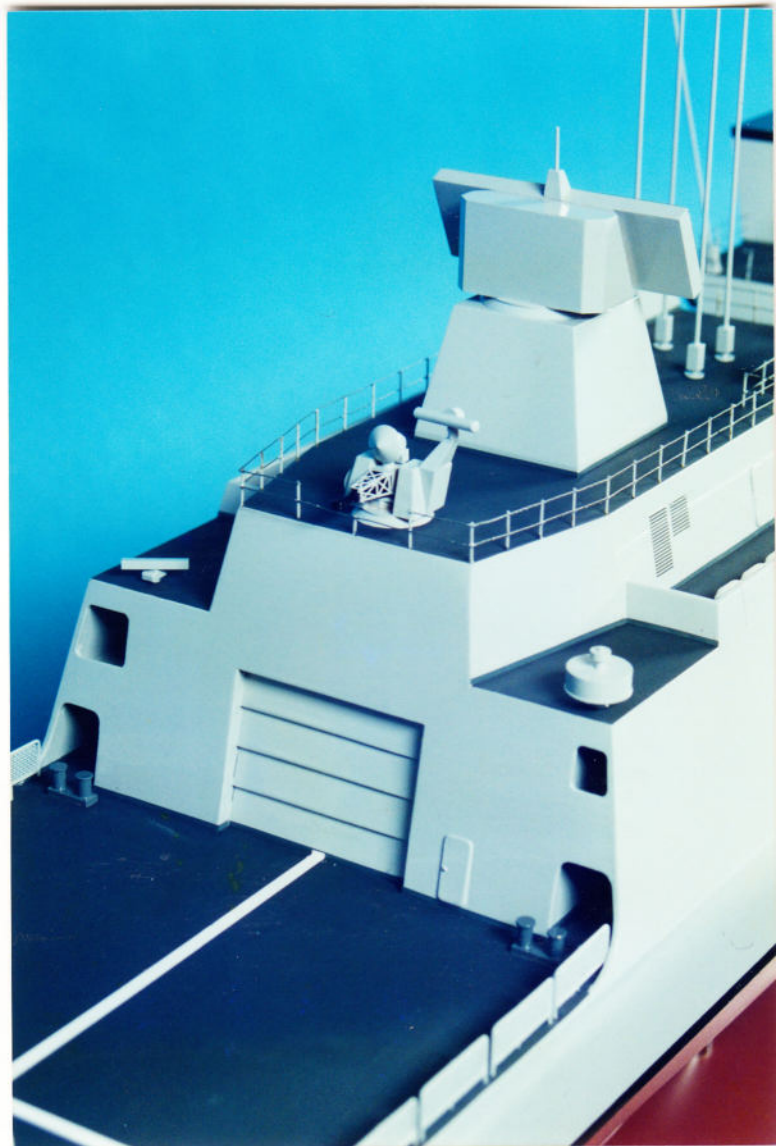

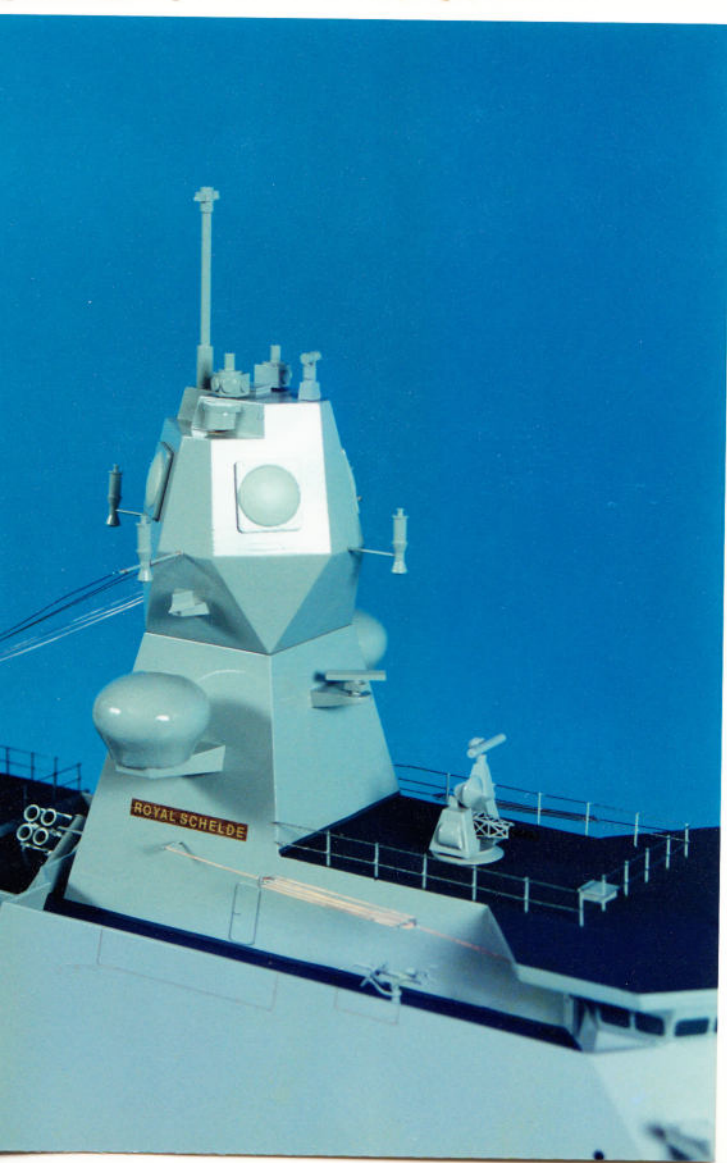

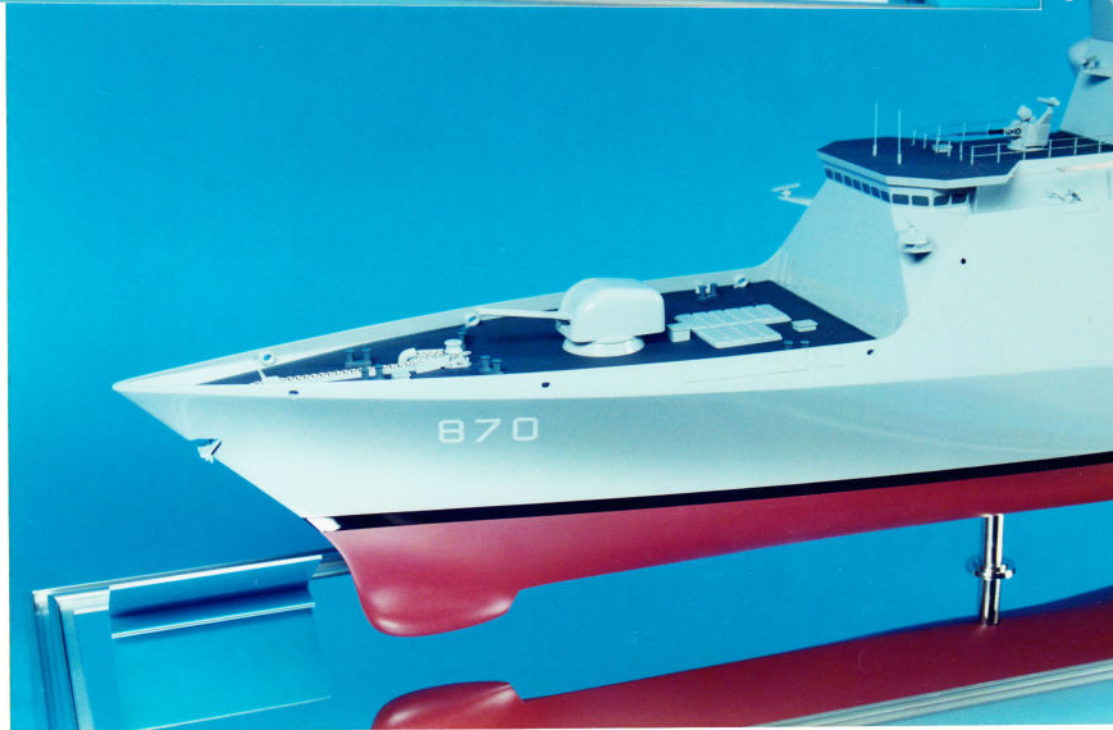



SCHULDE on H.S.N.

11/6/96

13/6/96

4
draaiend
radar.

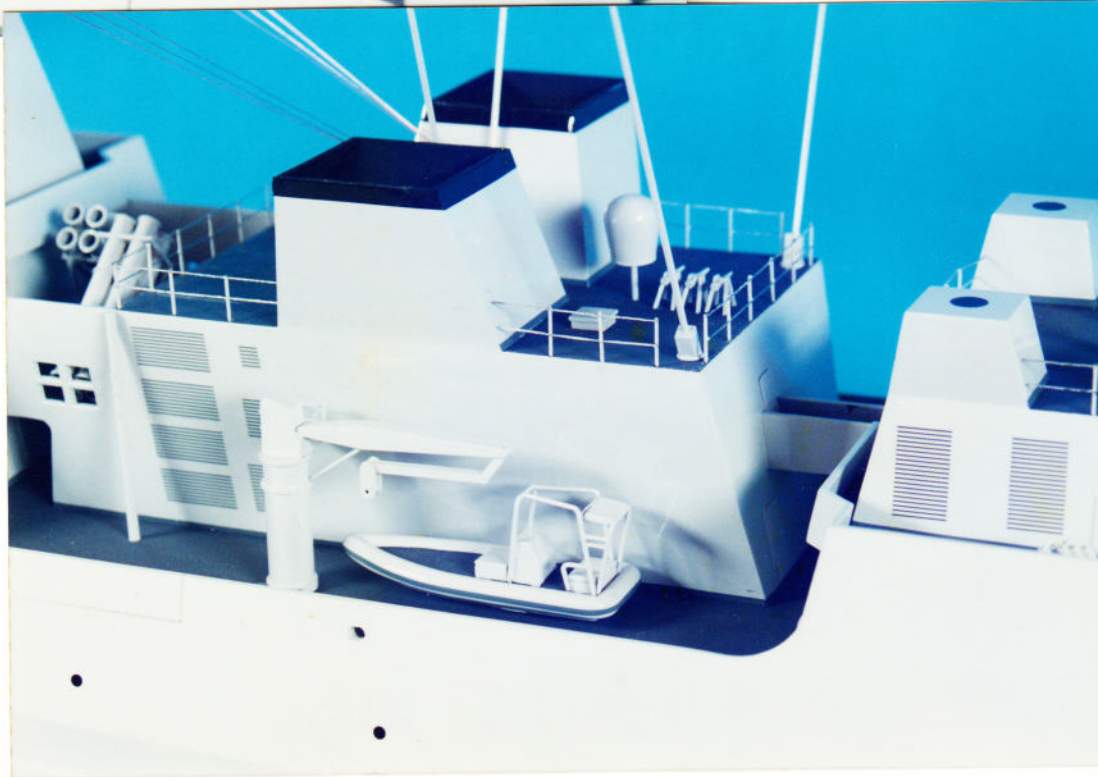
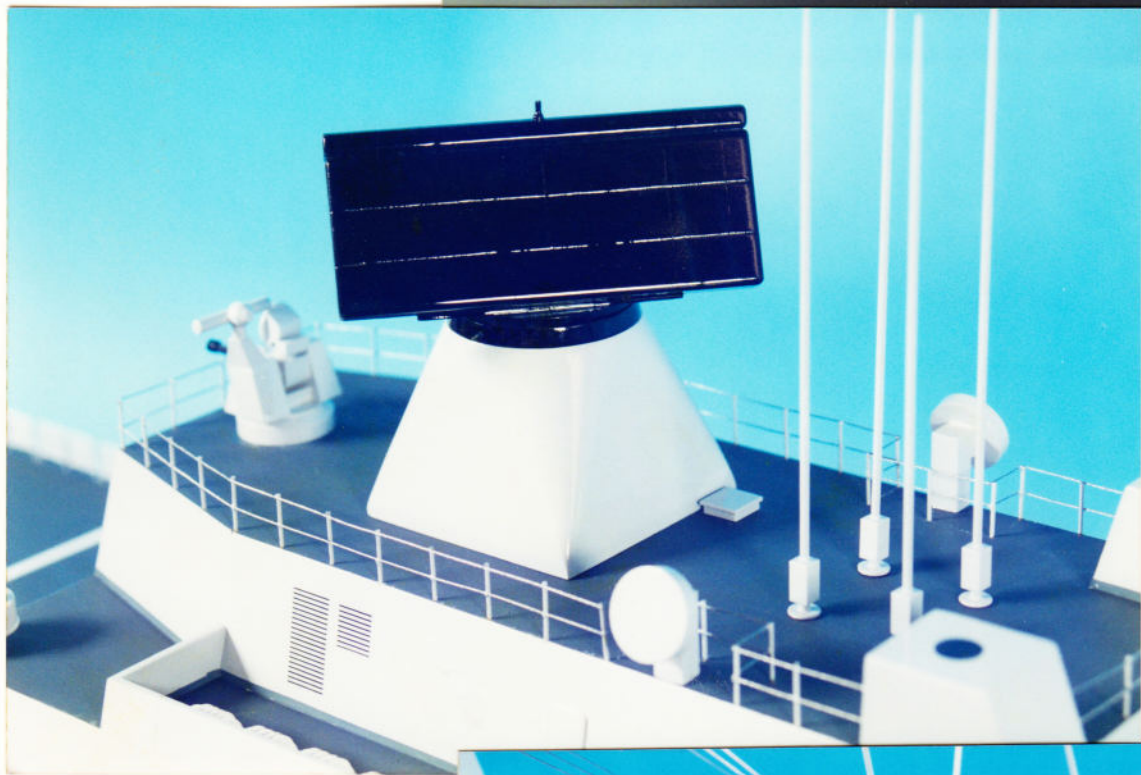

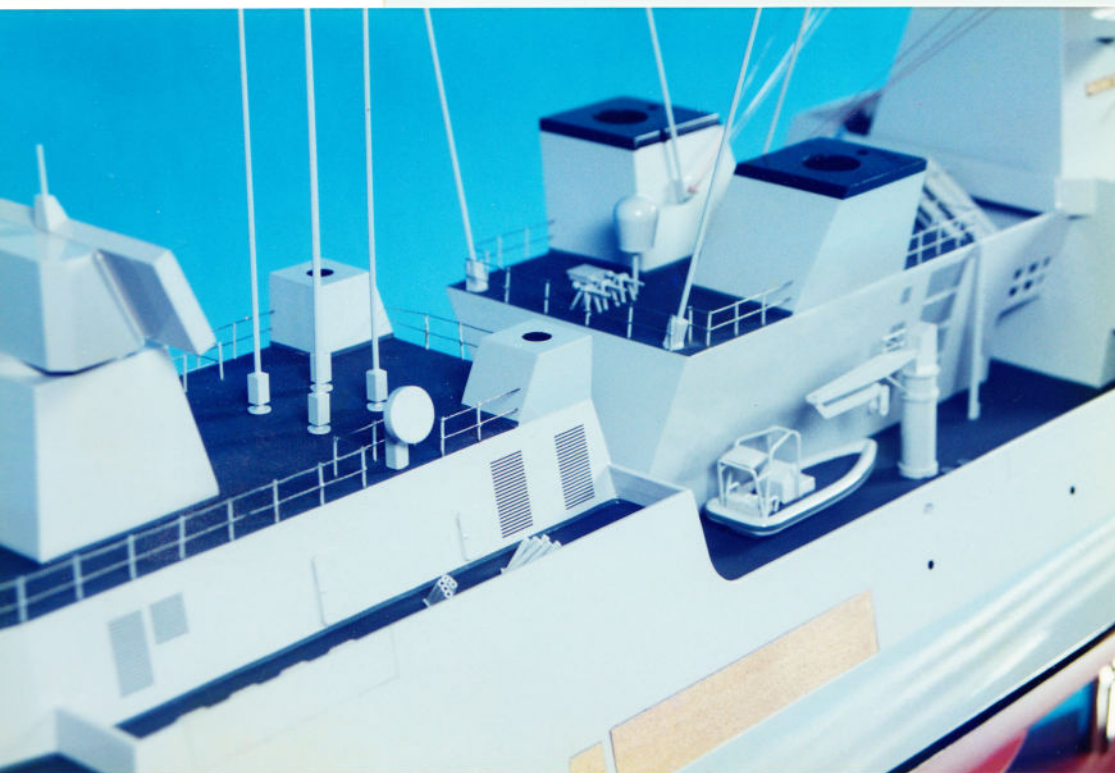

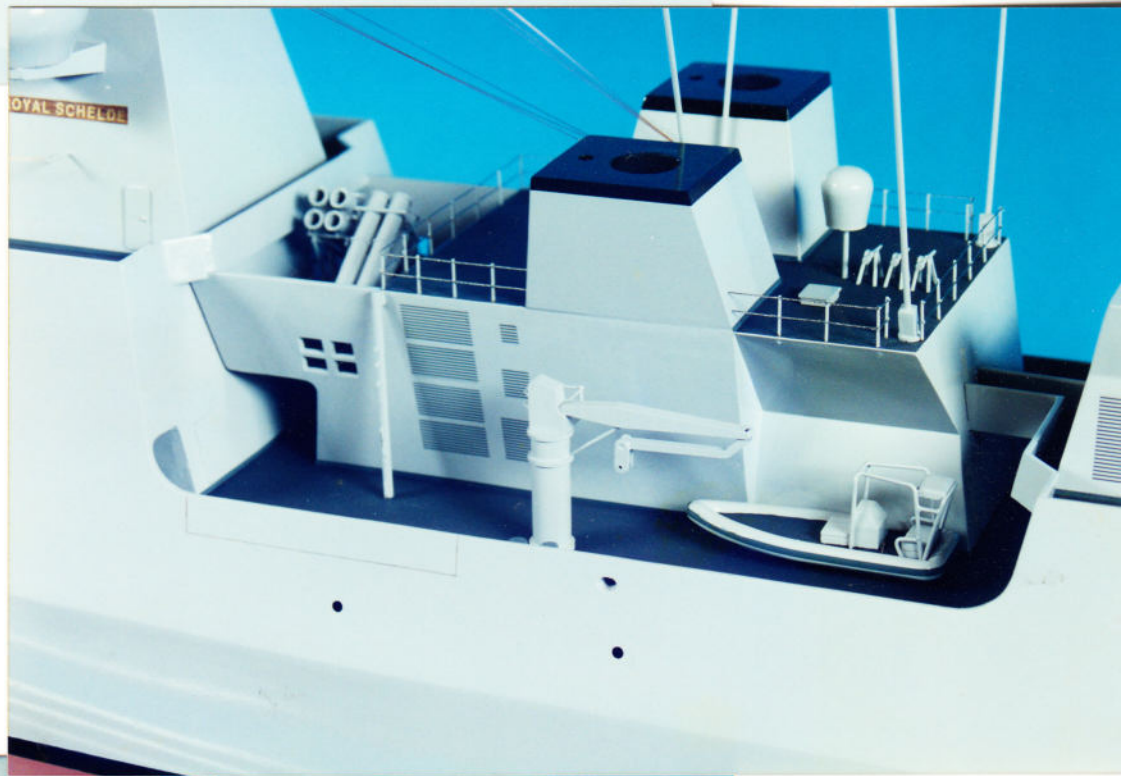
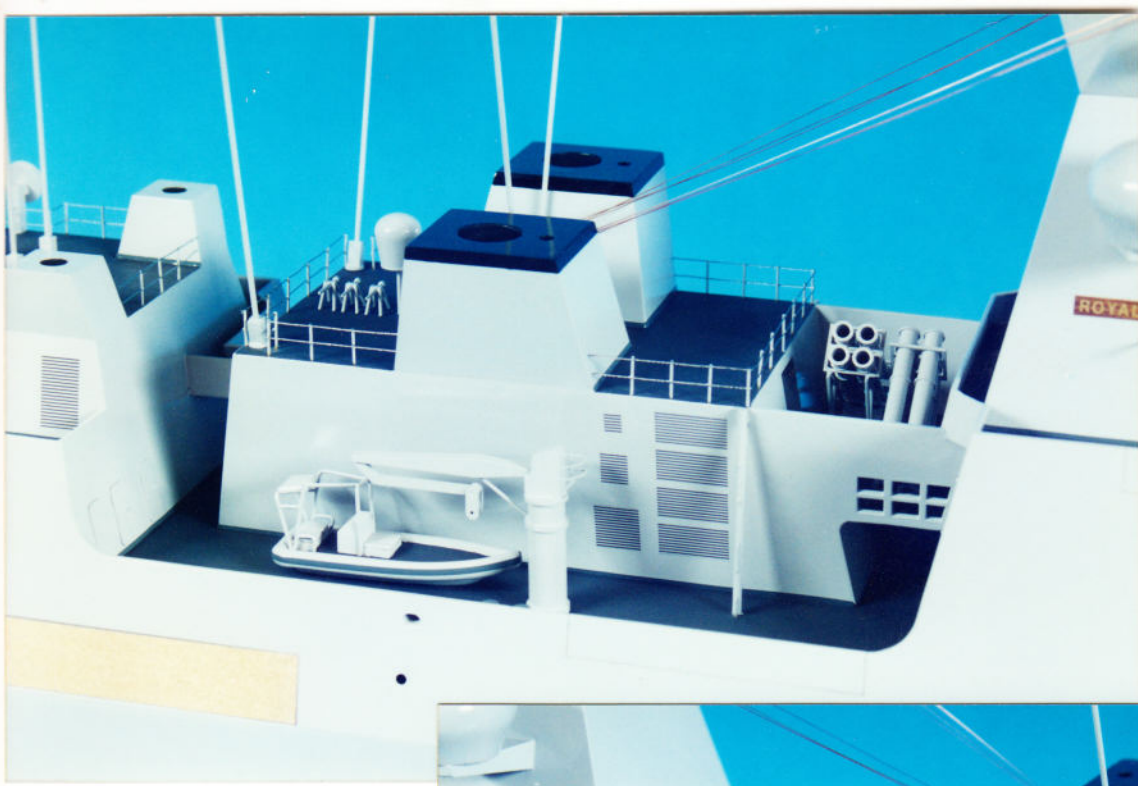

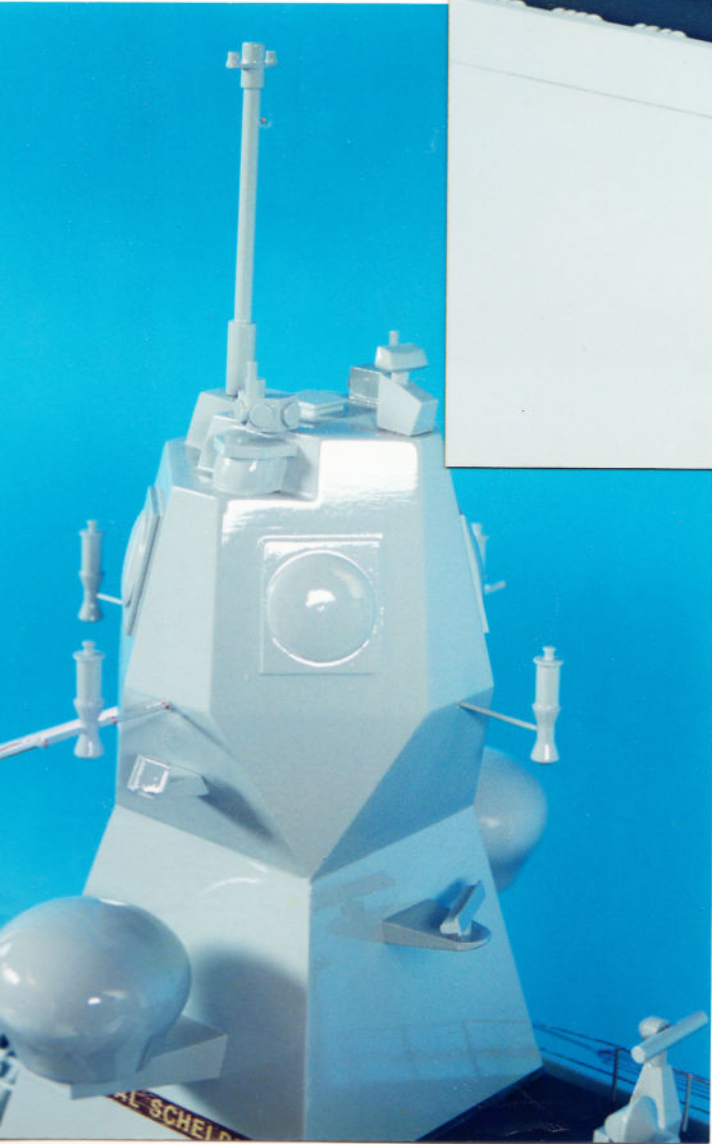
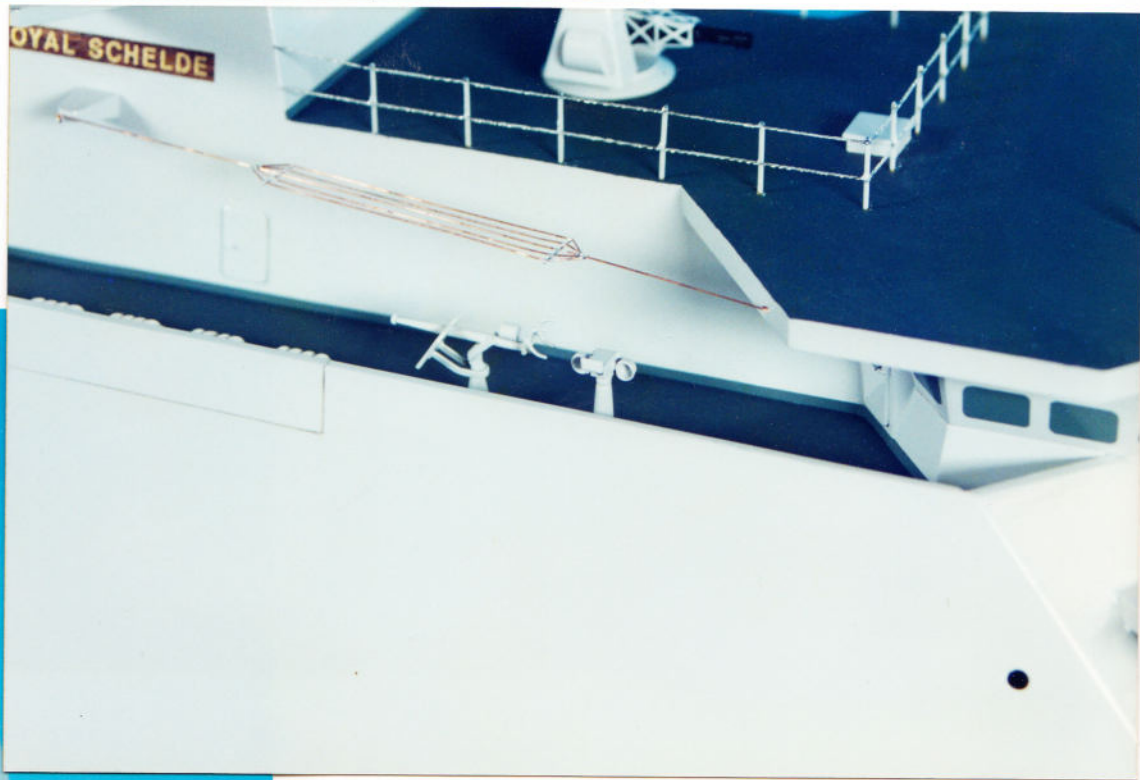
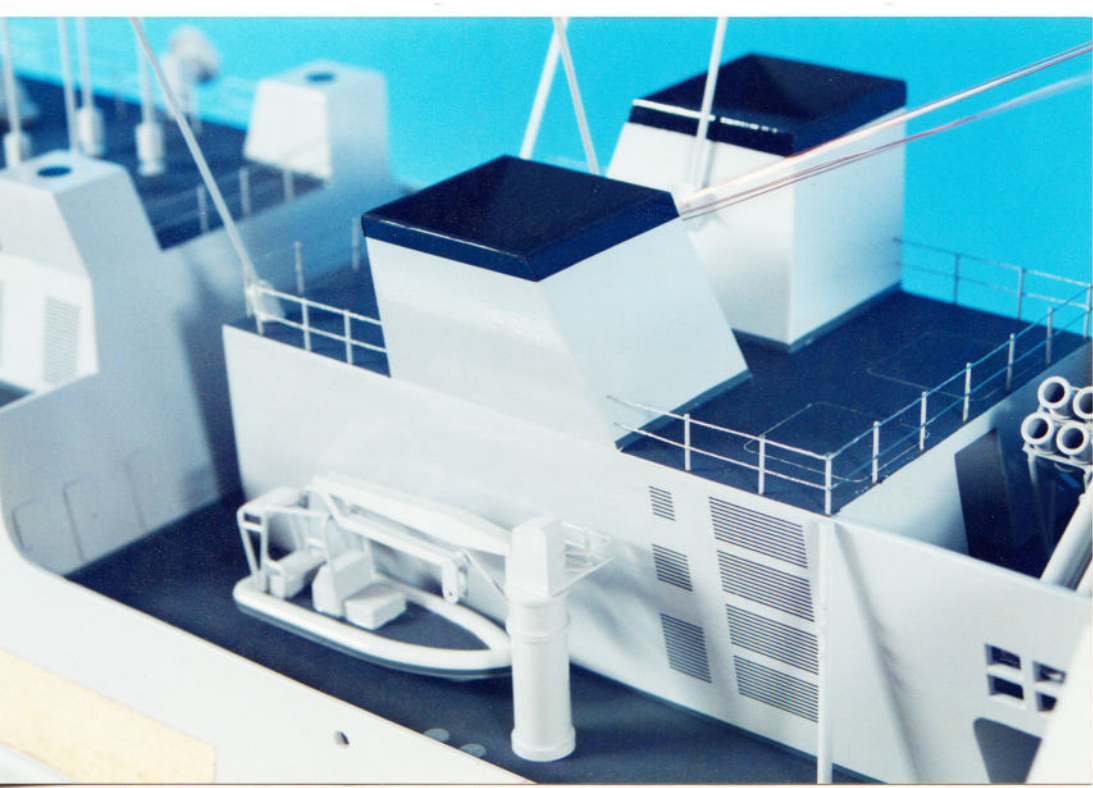

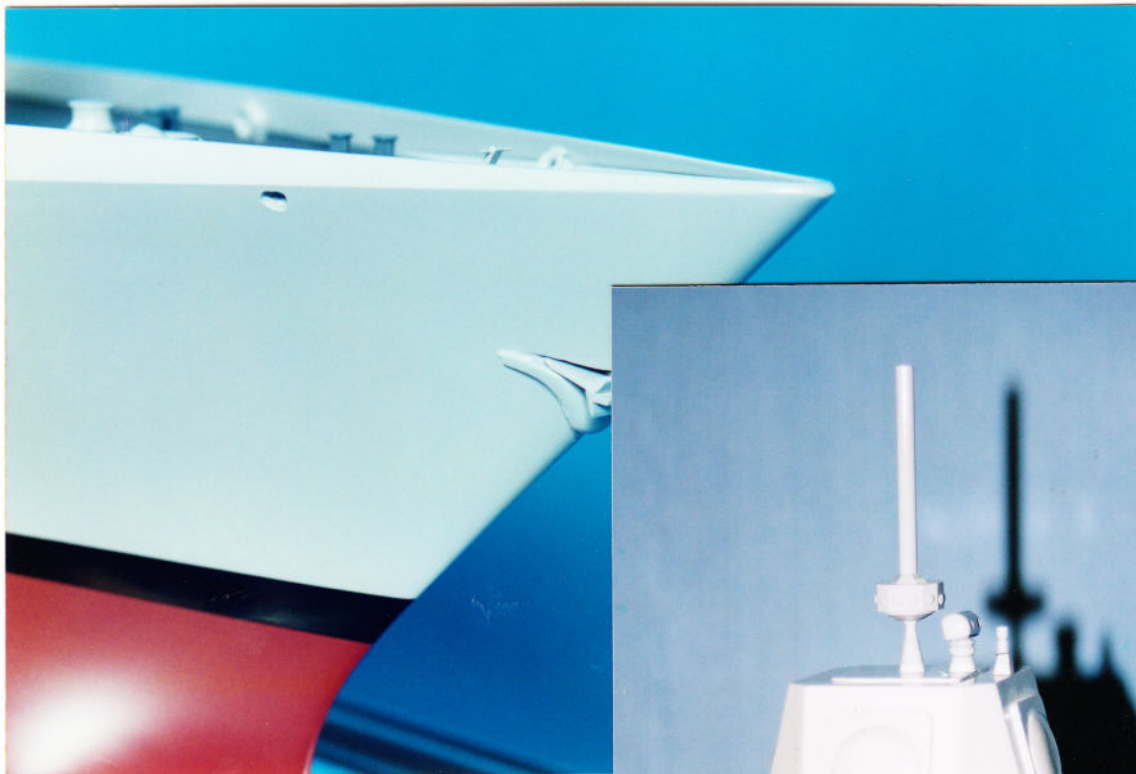

Gewyzigde kop 1-1-2001
VOOR H.S.A.



DE SCHELDE
8 Juli 1996
L.C.F. frigate
1:100
voor V.A.E.
(andere Heeren)
LOS w.v.



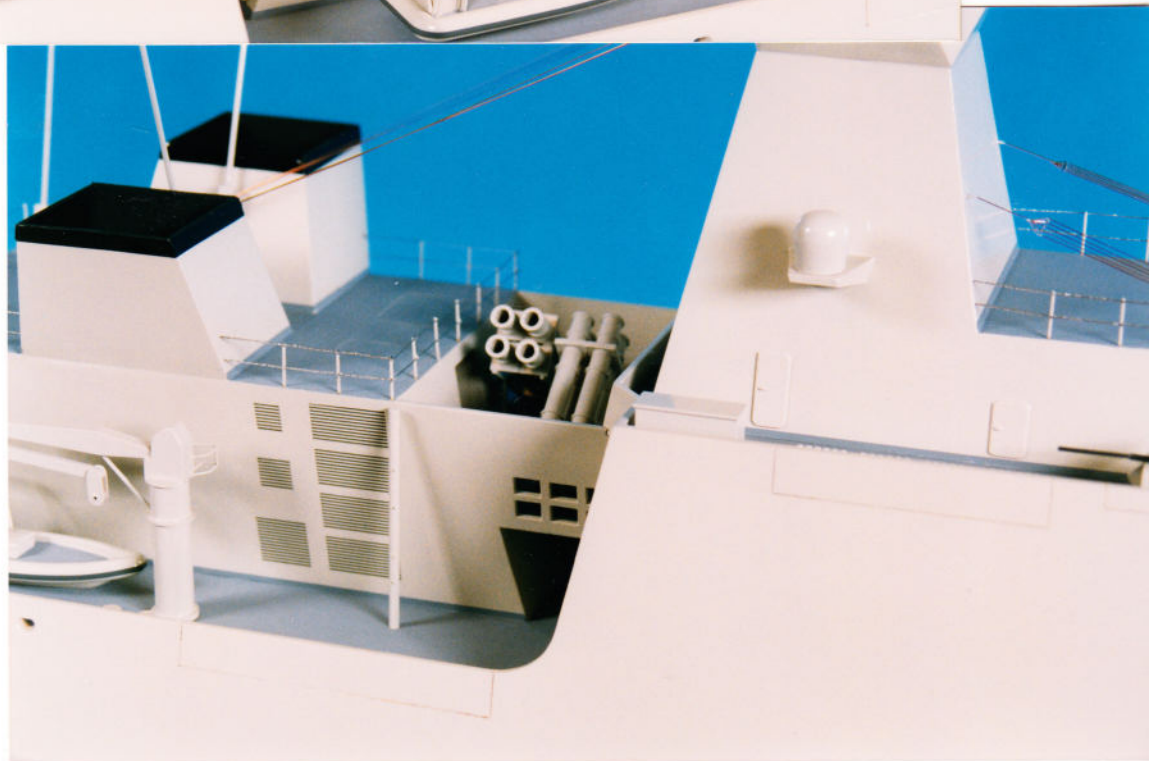
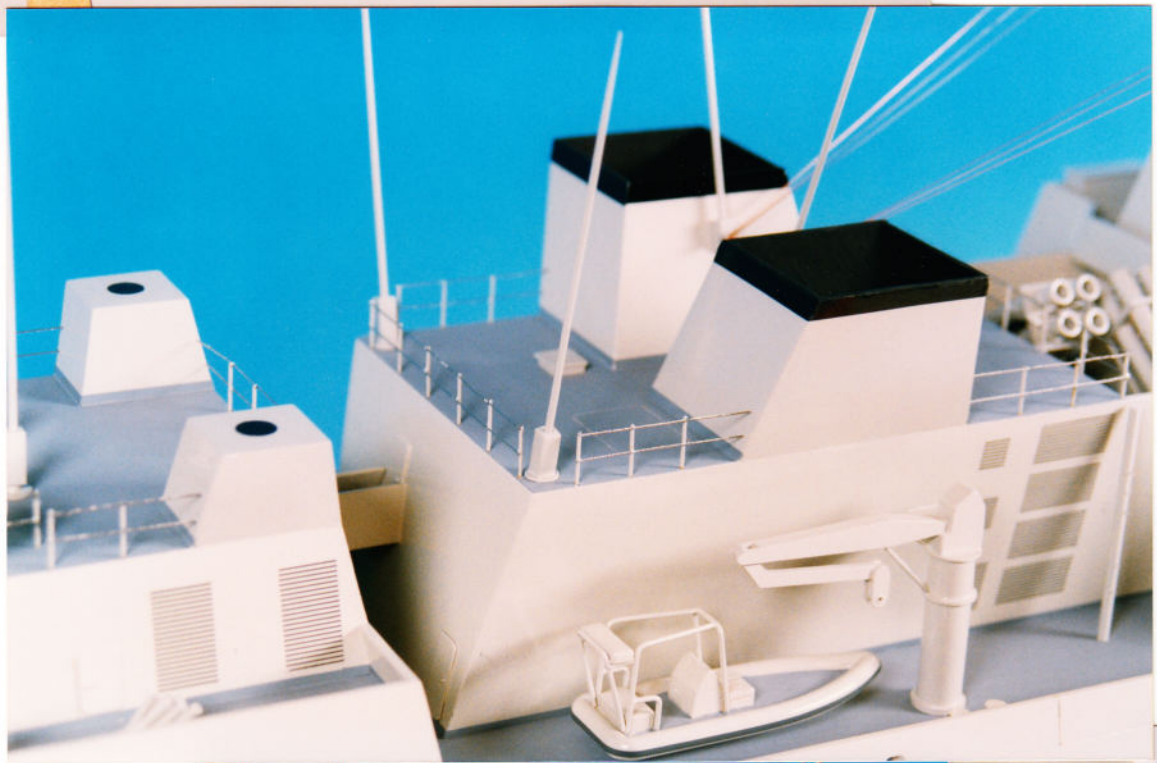

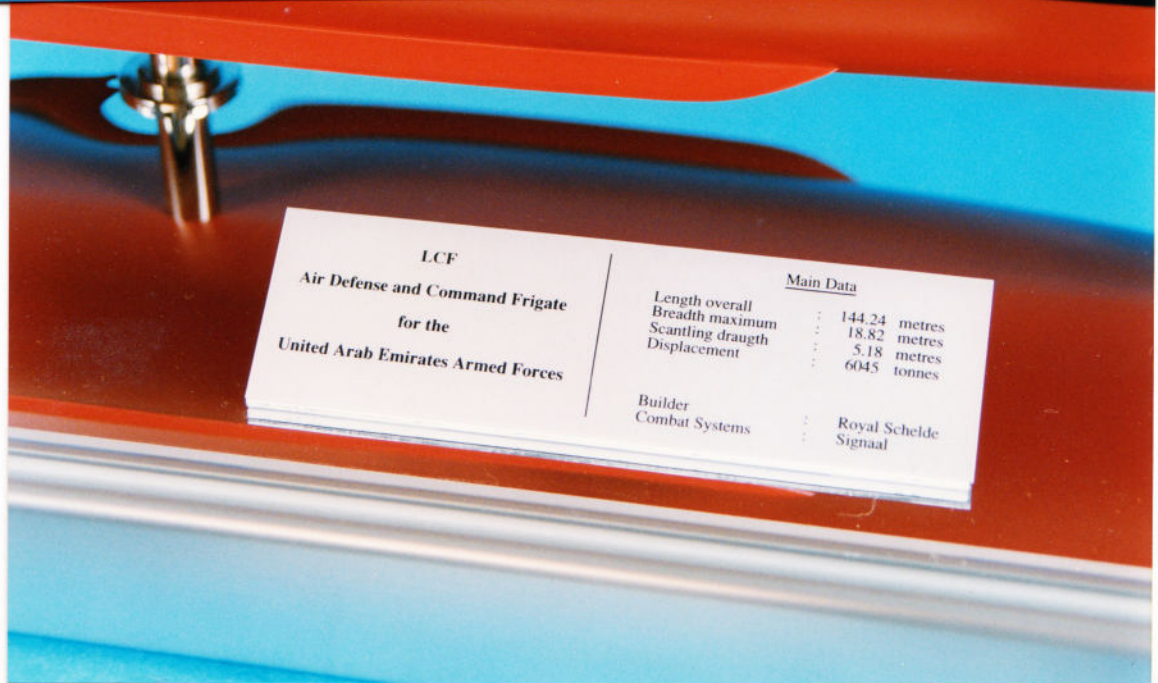
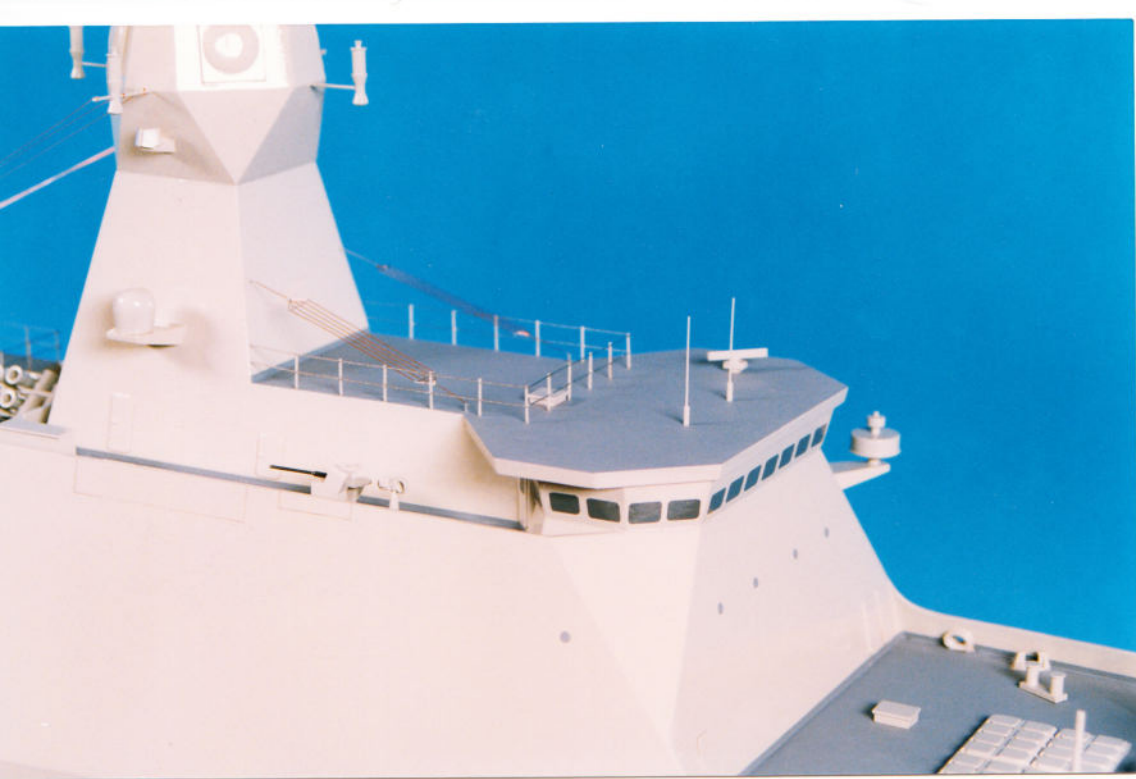

SCHHELDE
SEA ARROW
1:100

15/2/97.

229-uns.
(mit mal tofoel
Schip)

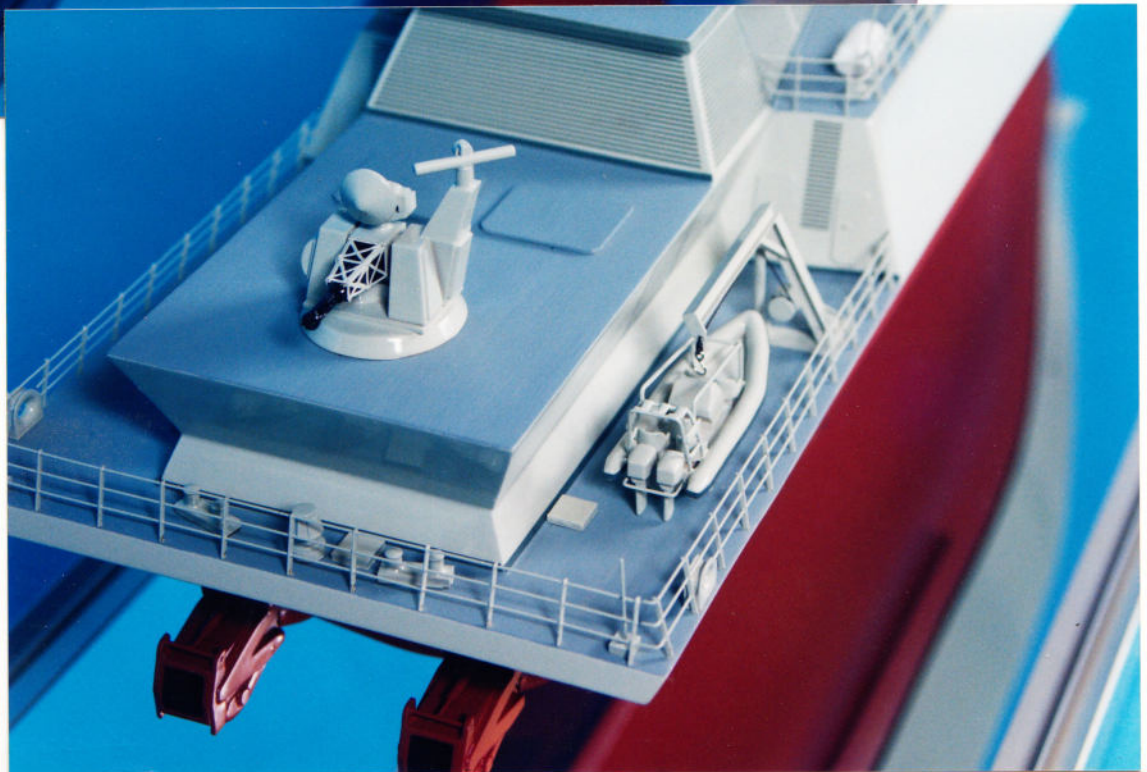
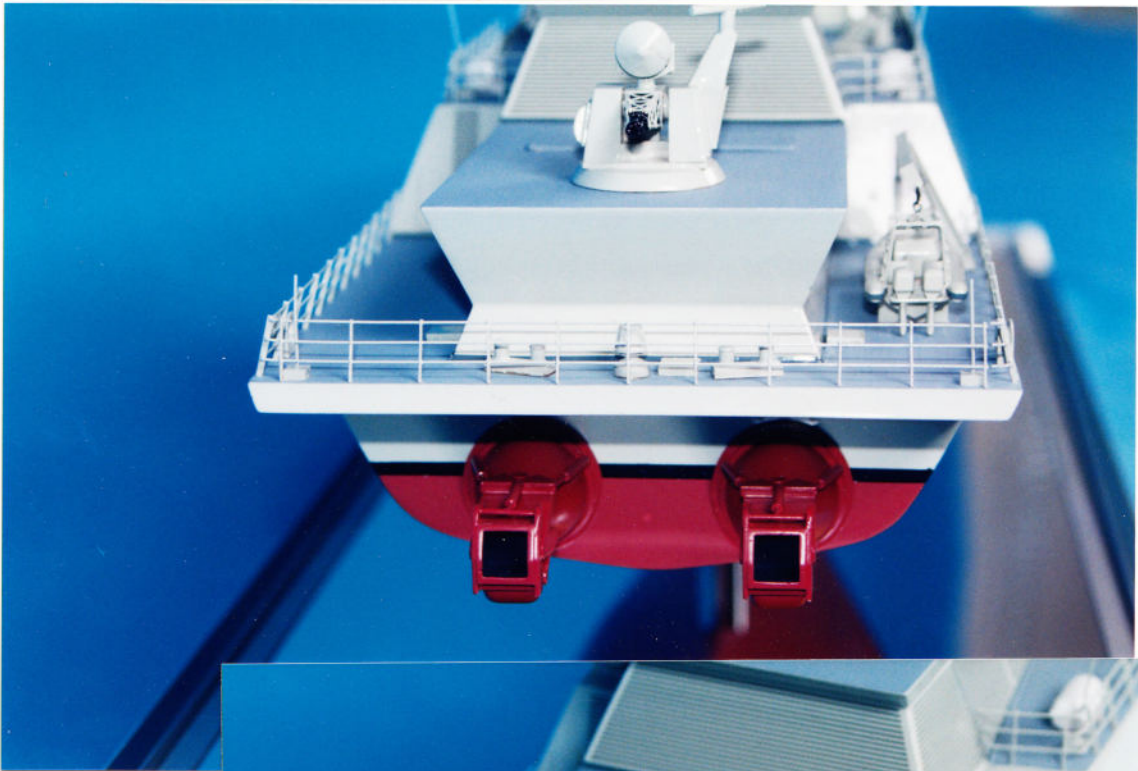

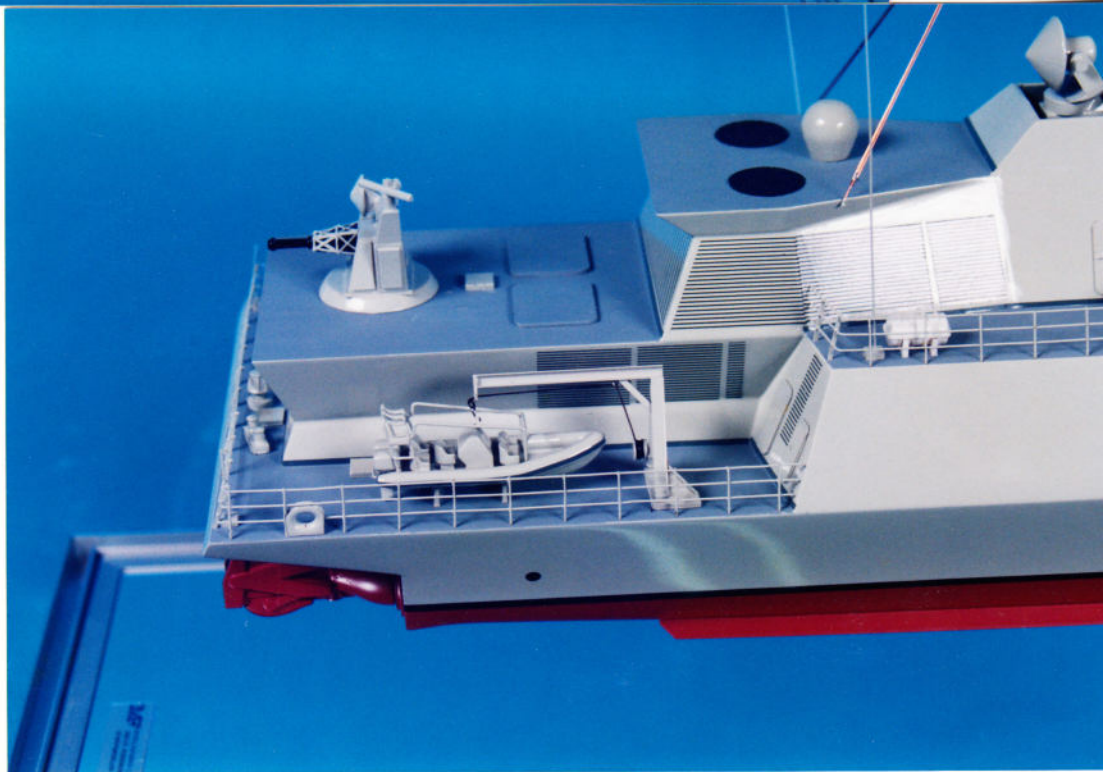
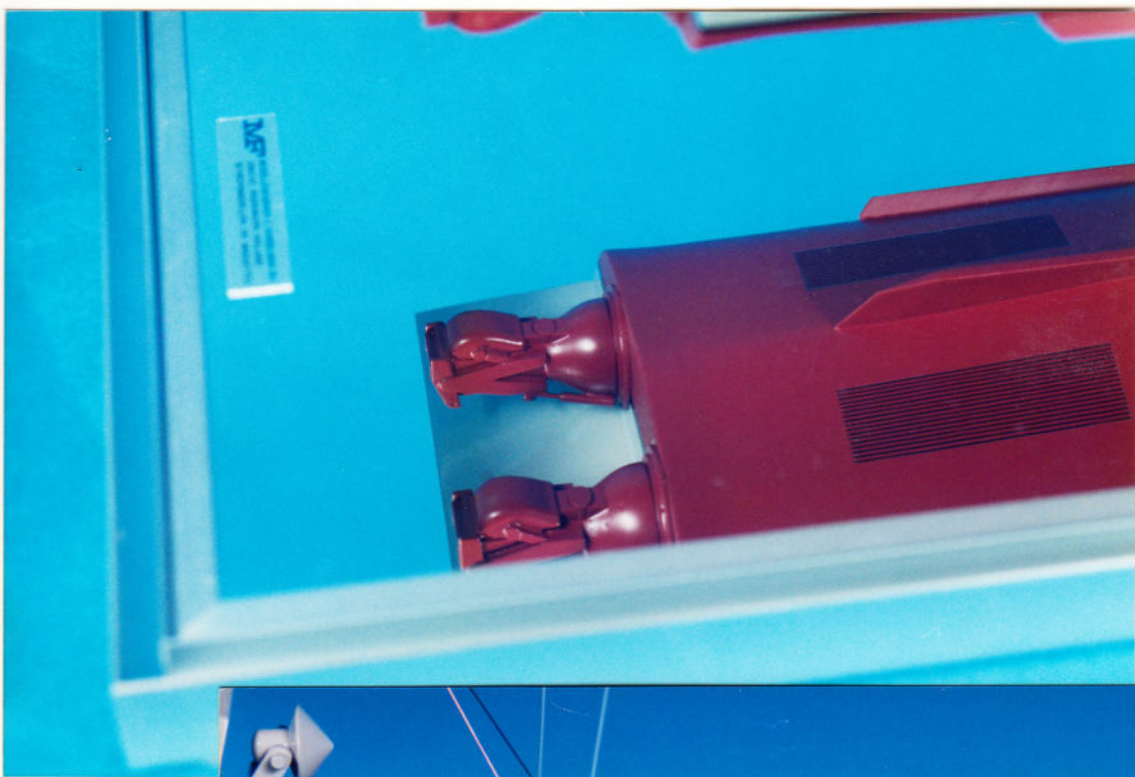

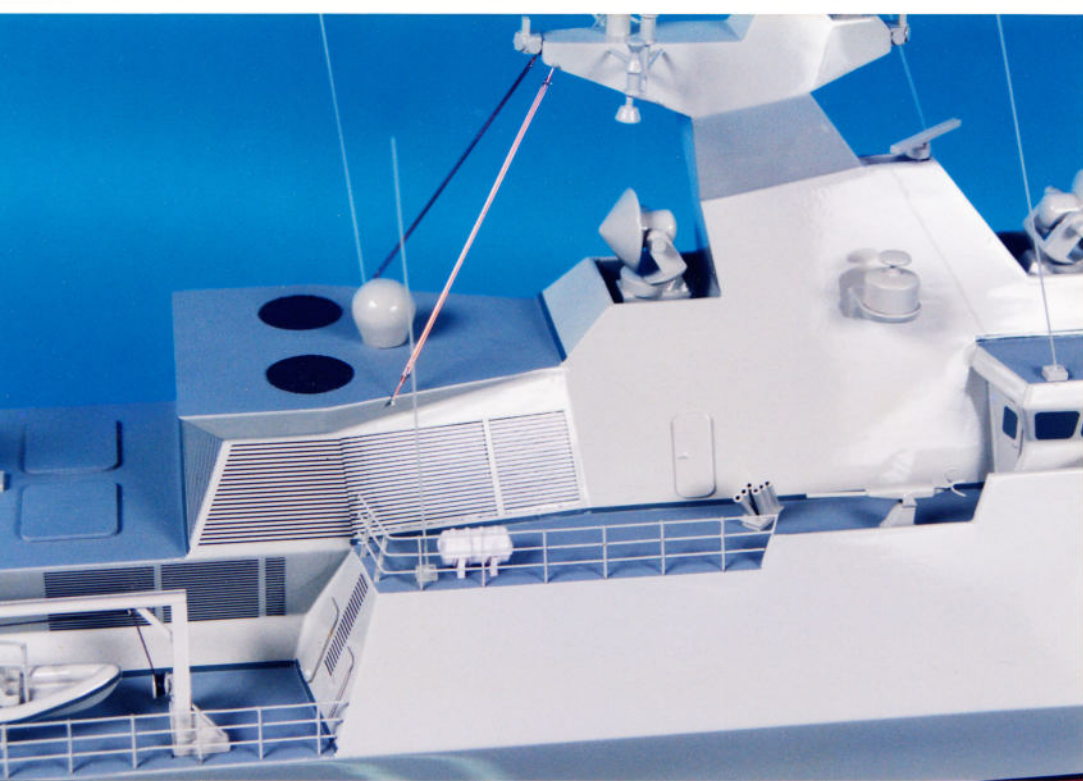

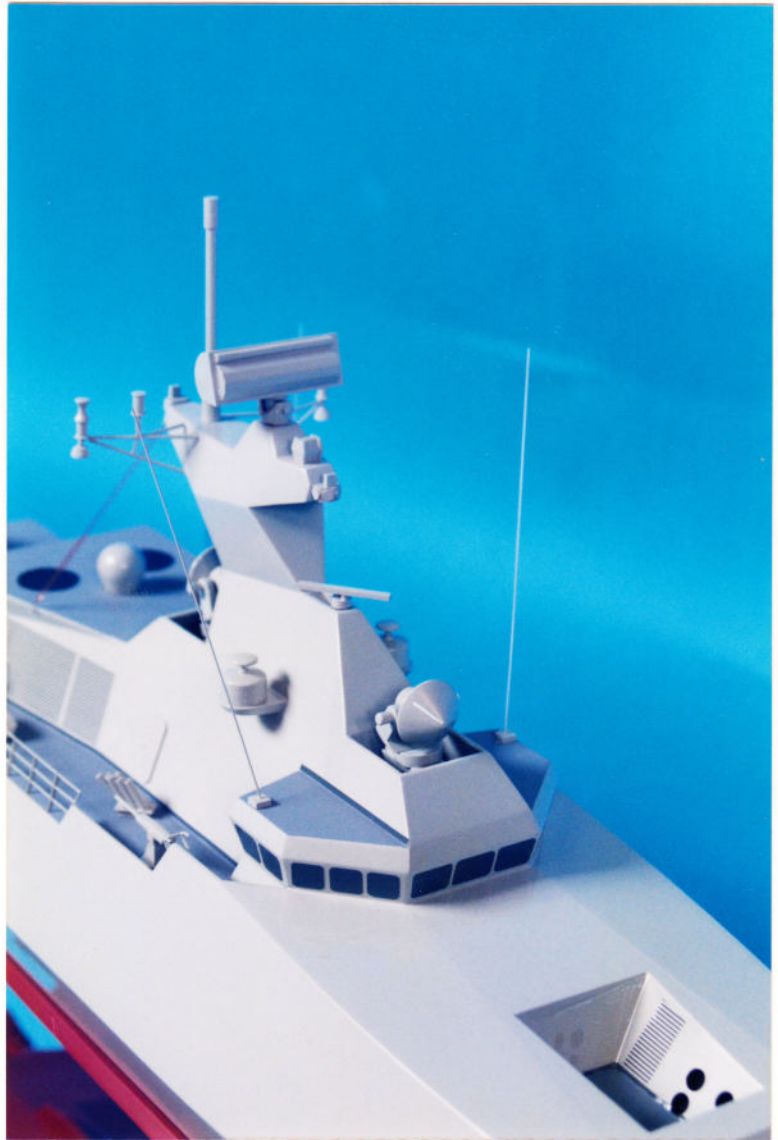





Sea Arrow 65

Sea Arrow 65

LENGTH O.A.	65.00 m
BREADTH MAX.	13.80 m
DEPTH 1-DECK	6.50 m
DRAUGHT	3.50 m
DISPLACEMENT MAX.	1190 TONNES
COMPLEMENT MAX.	24 + 18
SPEED MAX.	35 KN

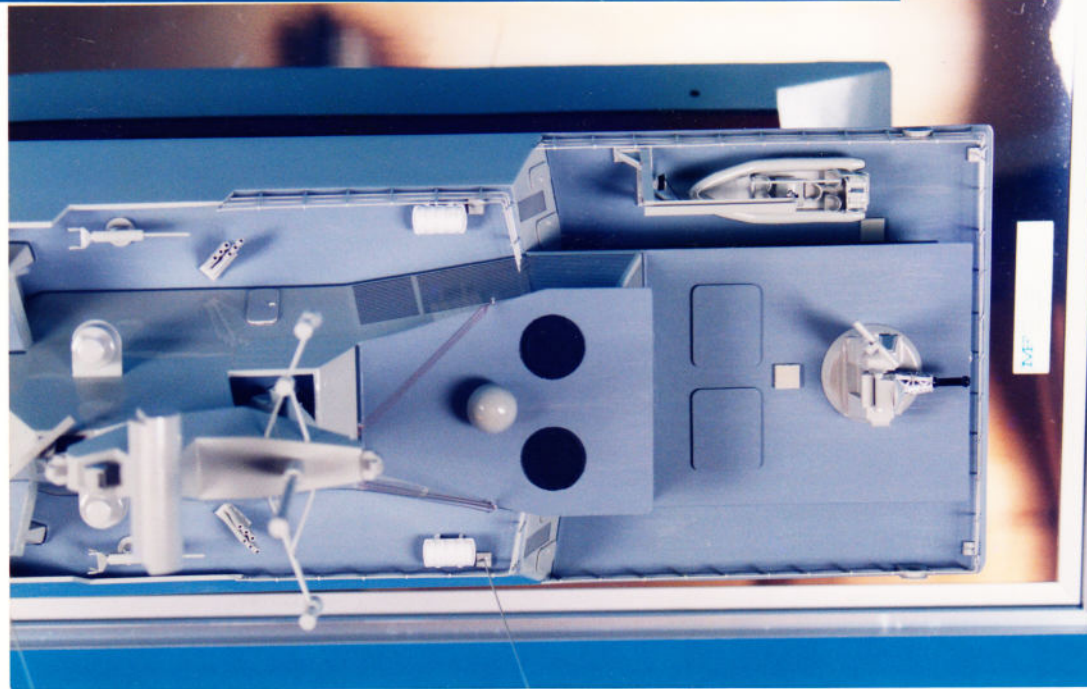
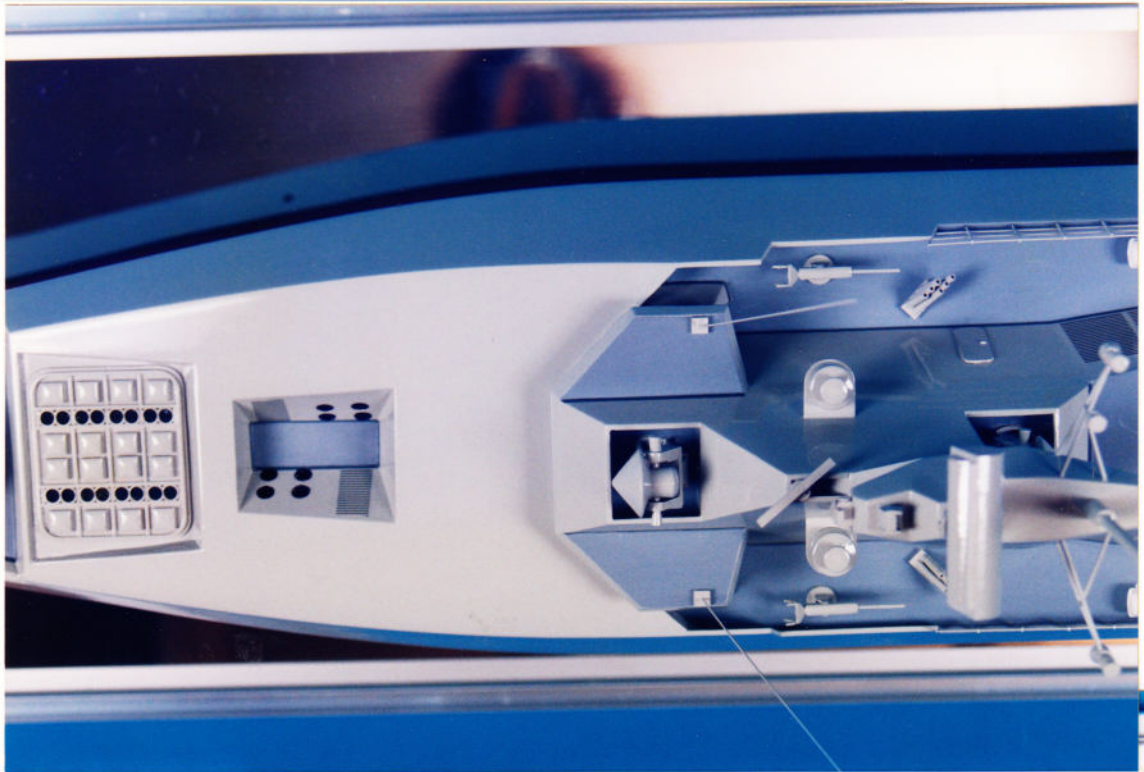



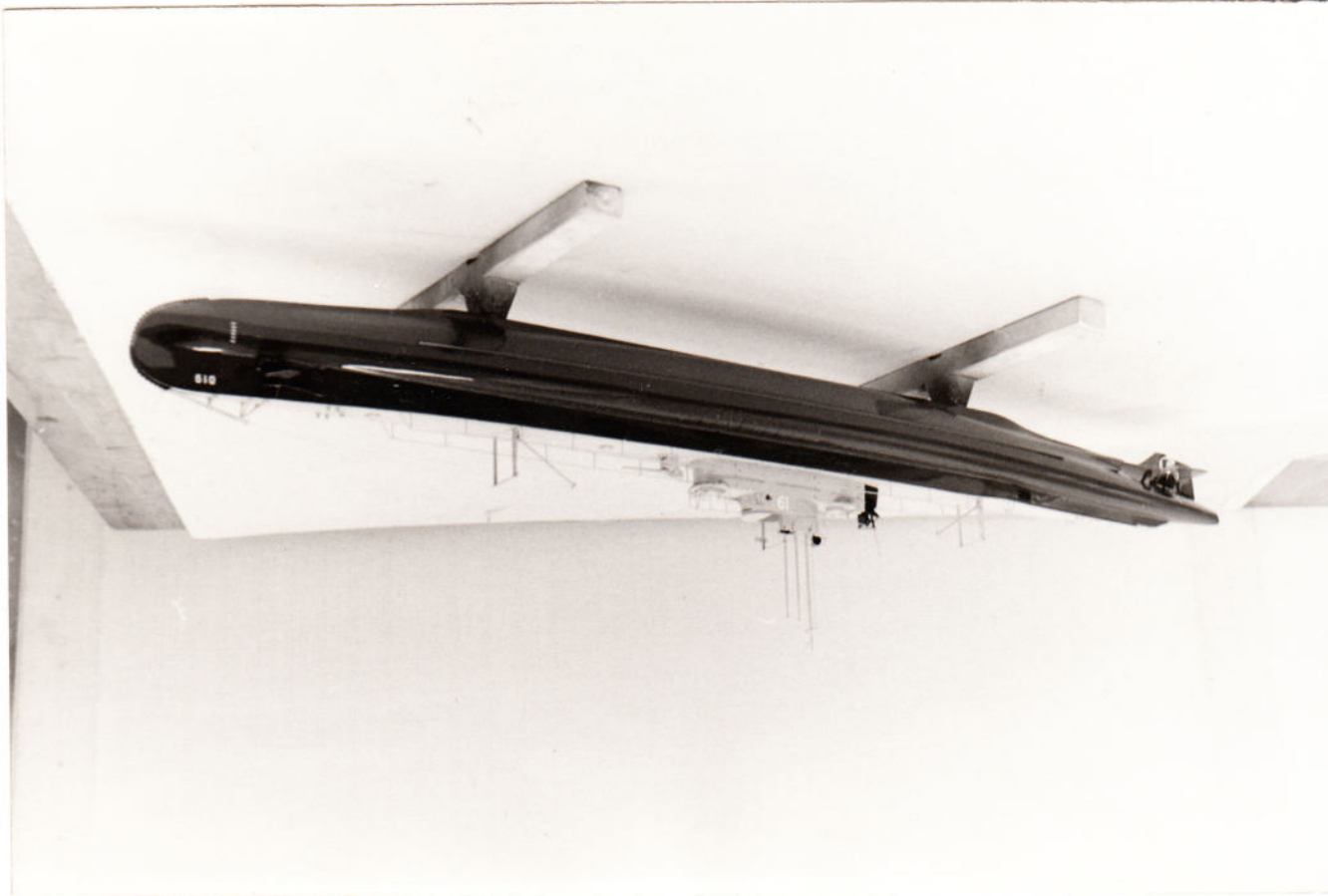
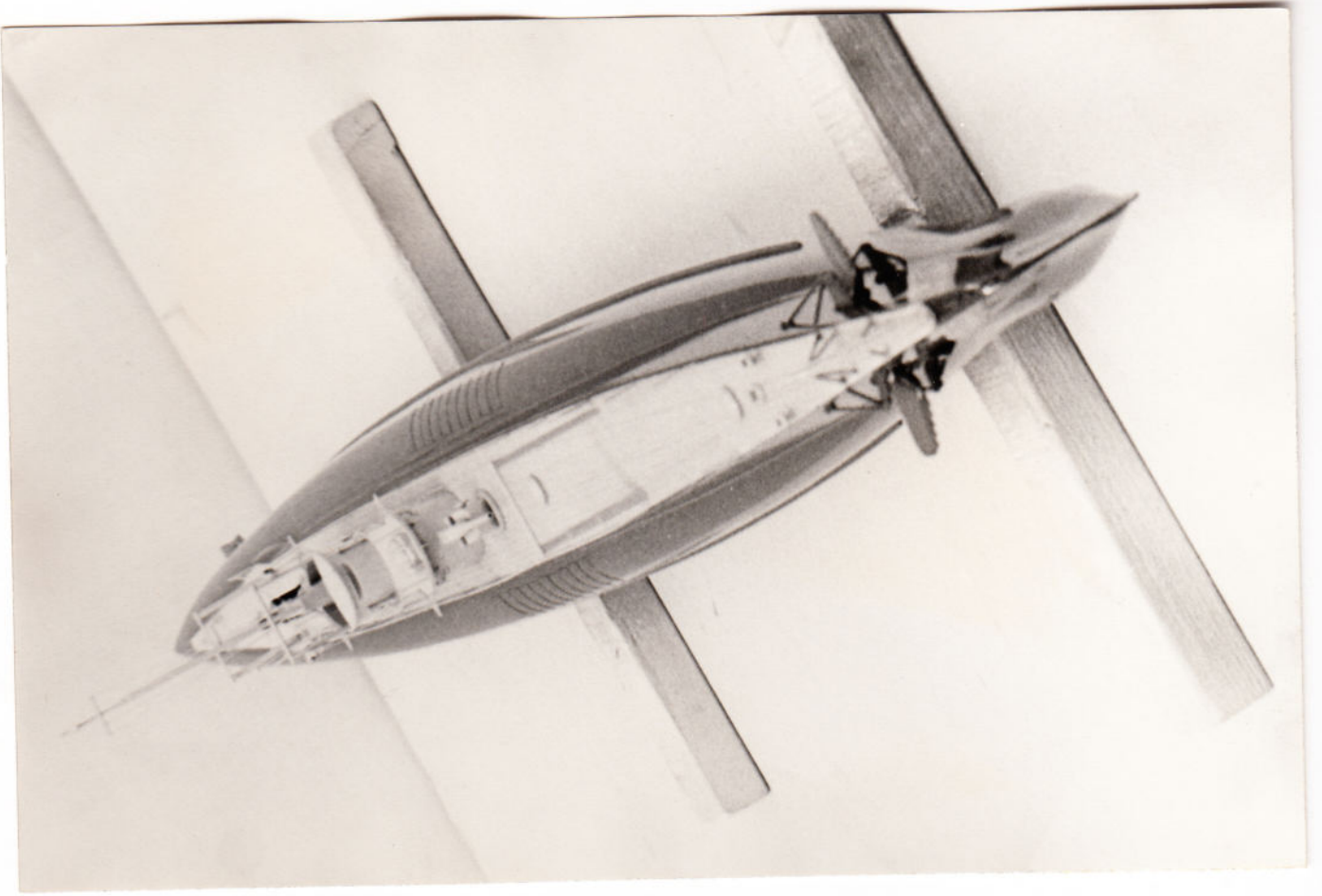

019
2x
1965
NEWSBY
1:100

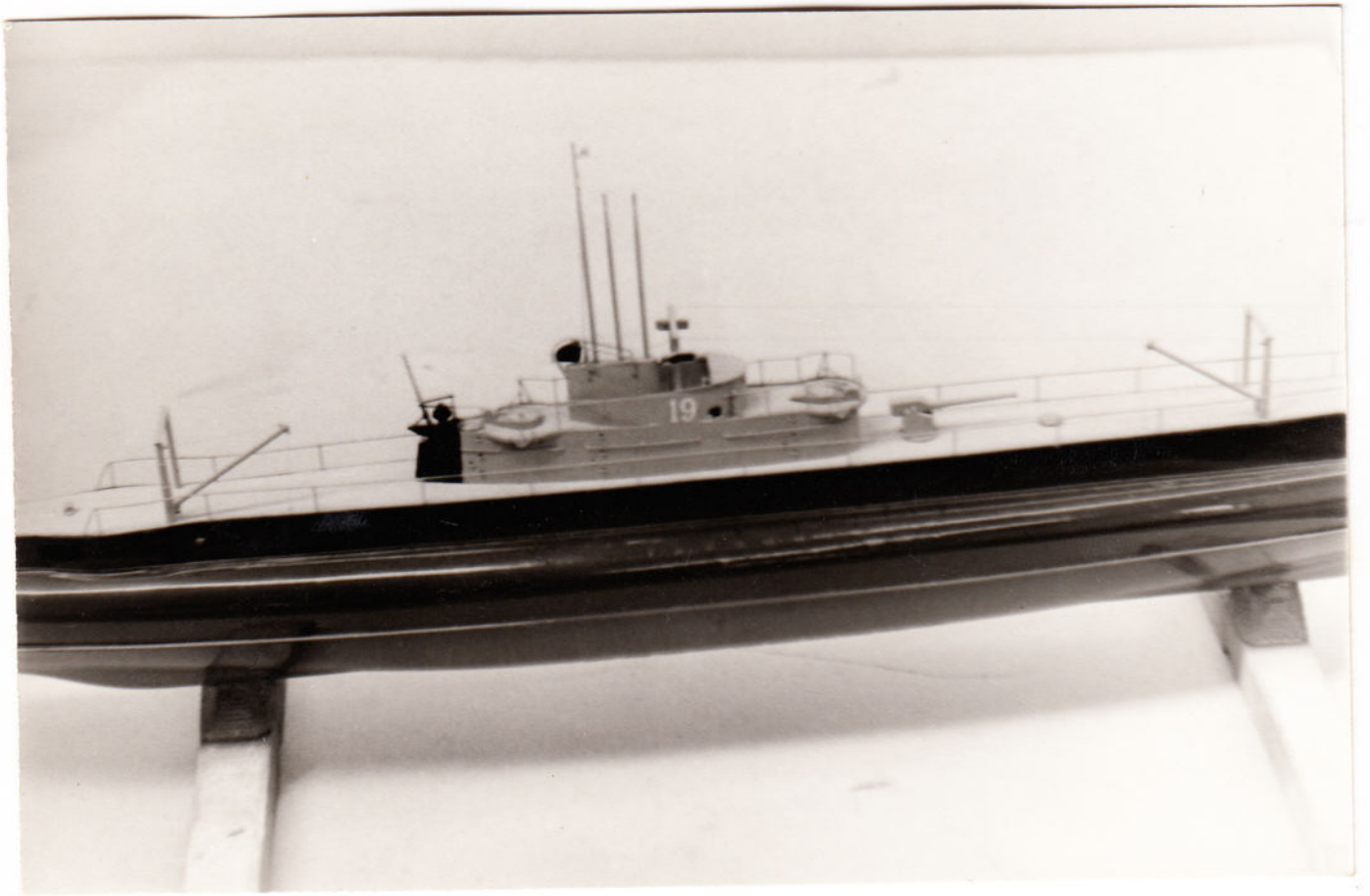
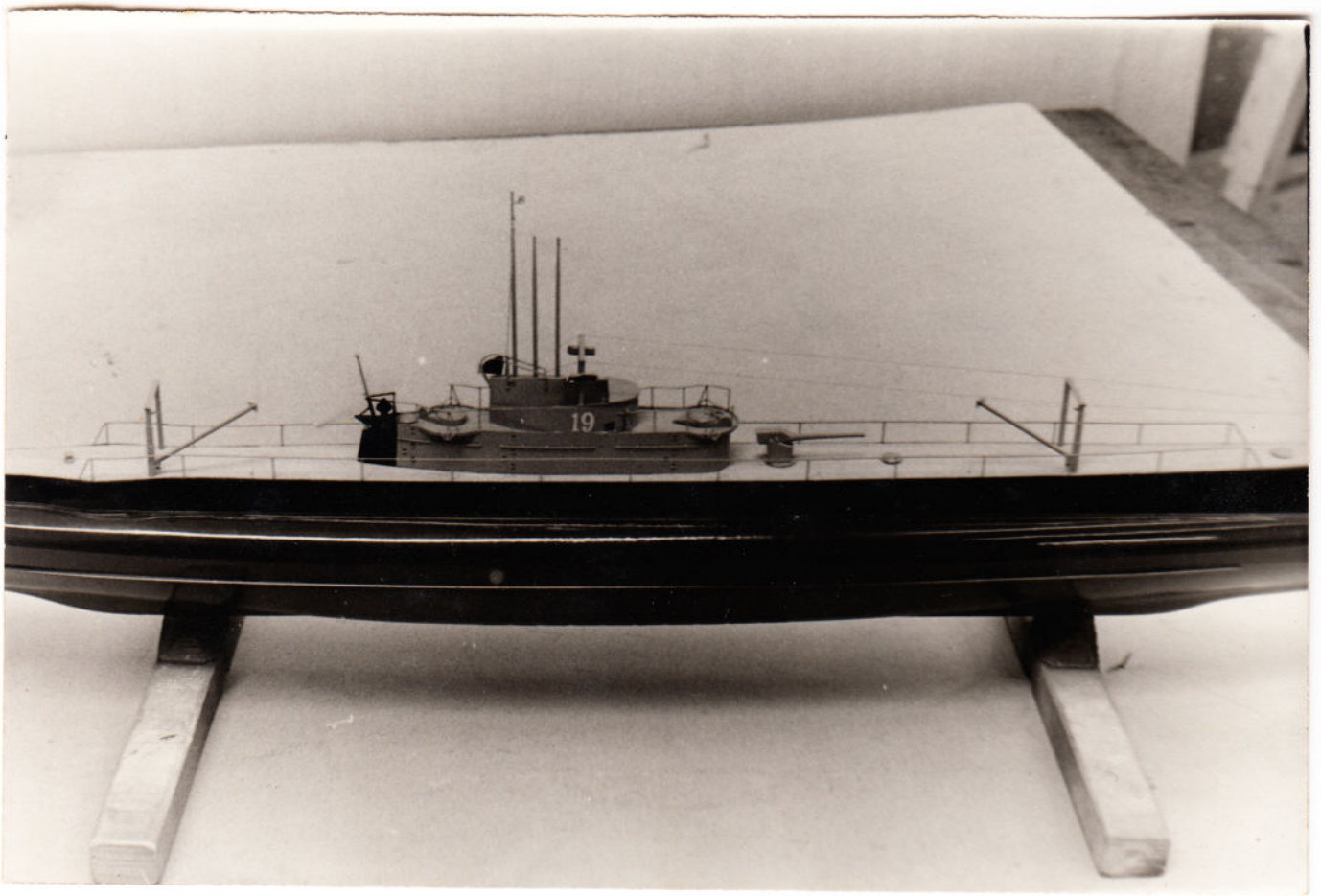

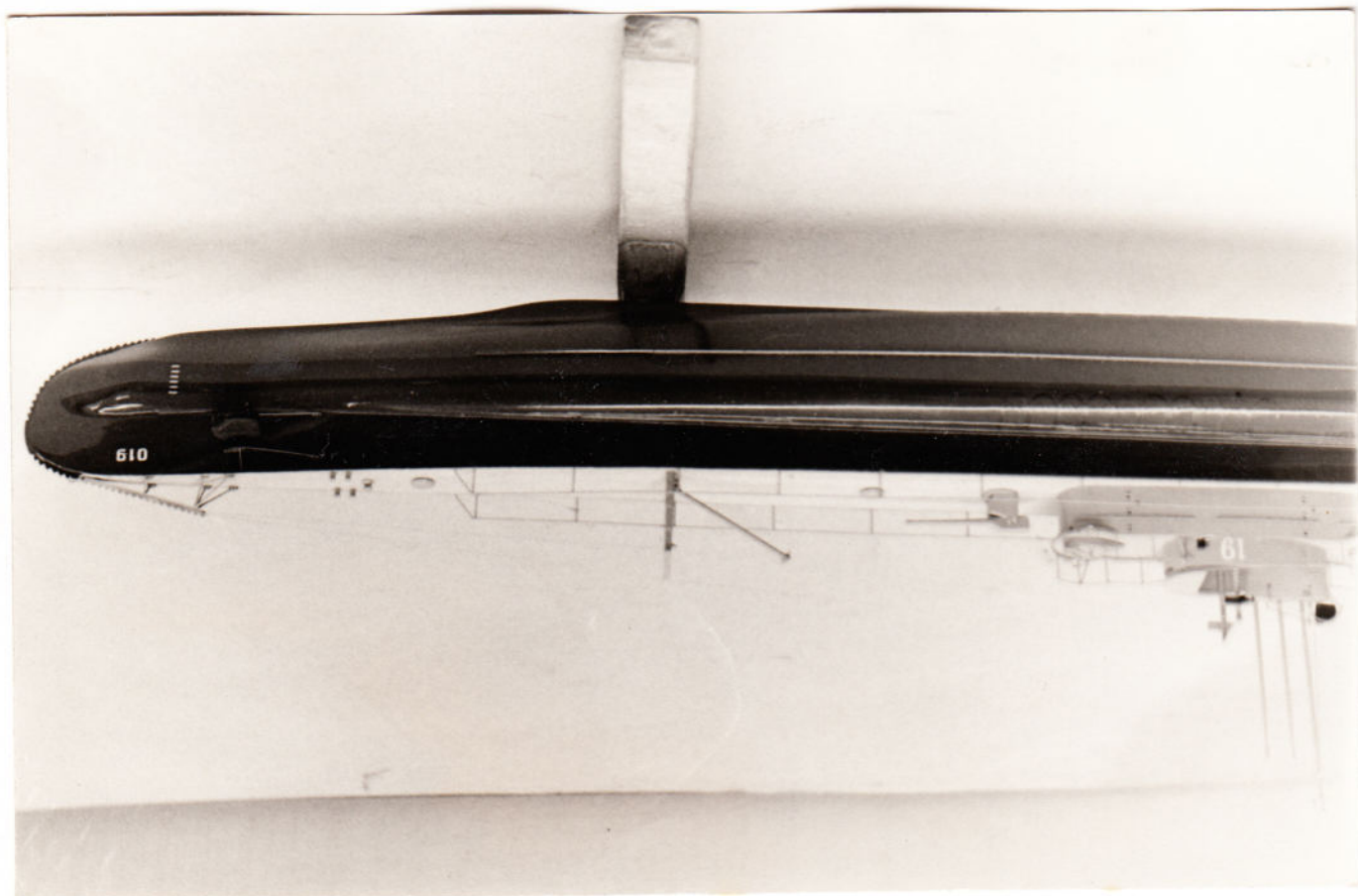
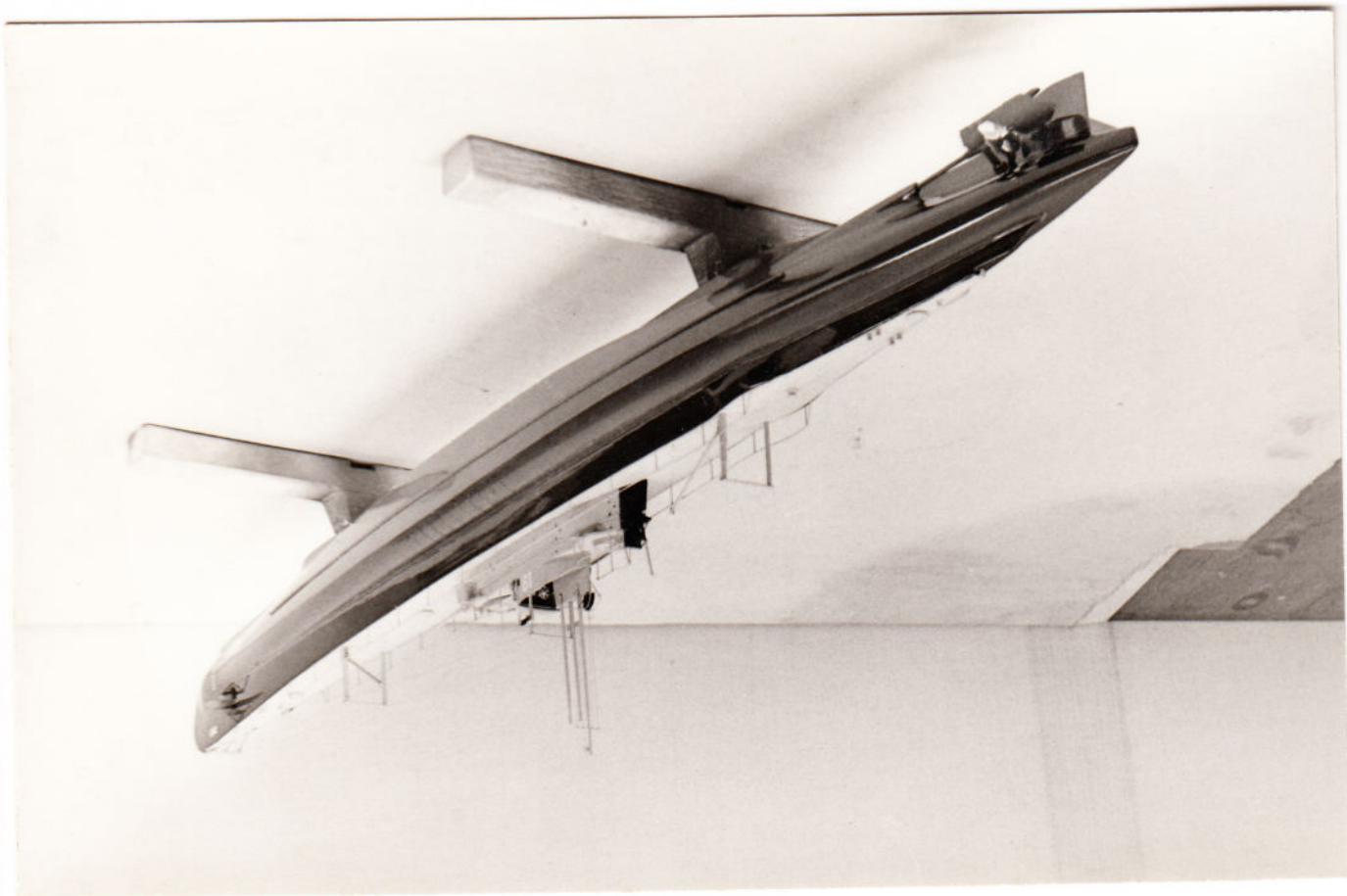

Marine

1966

Potvis +

doornsteden

1840

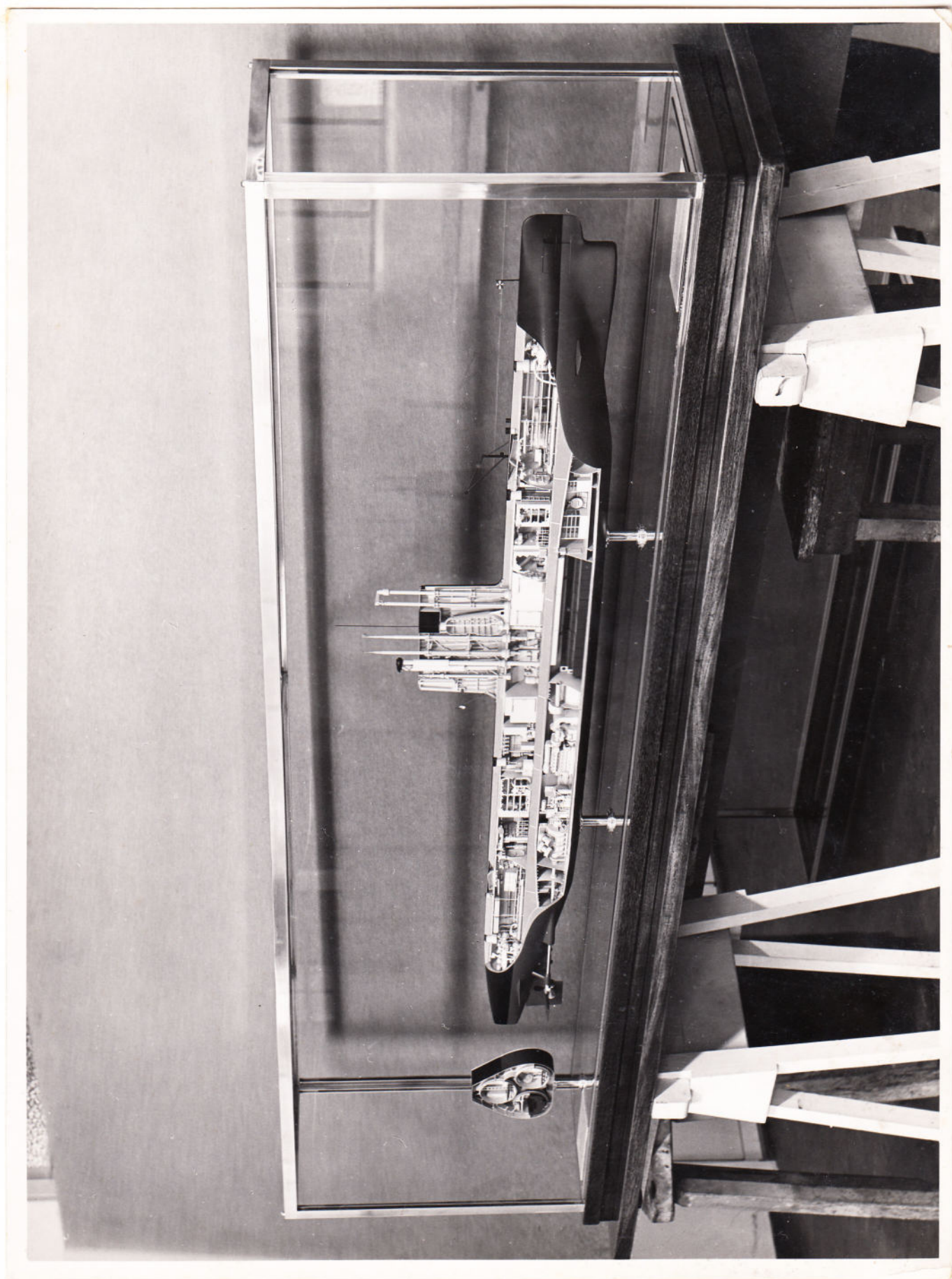

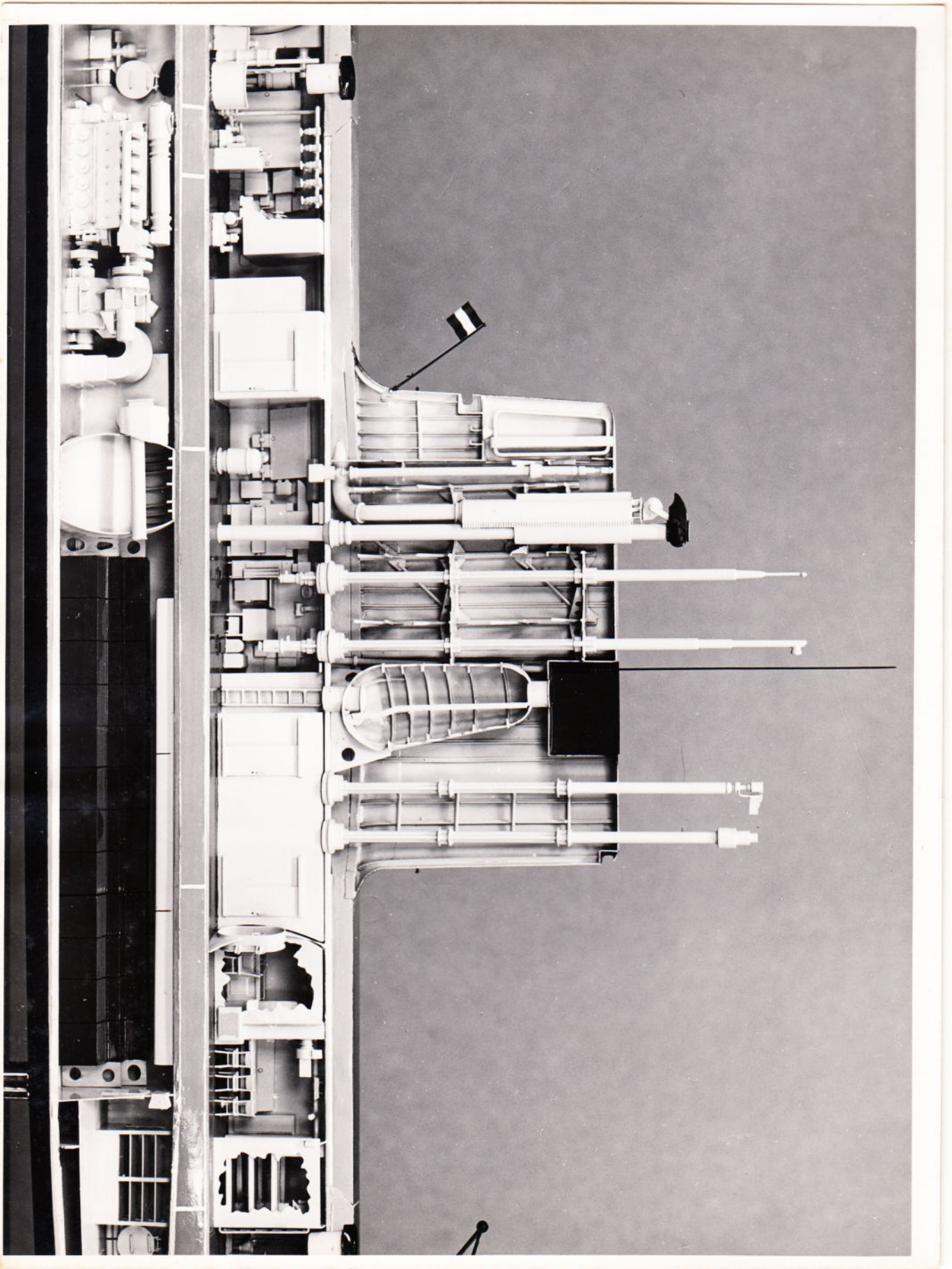

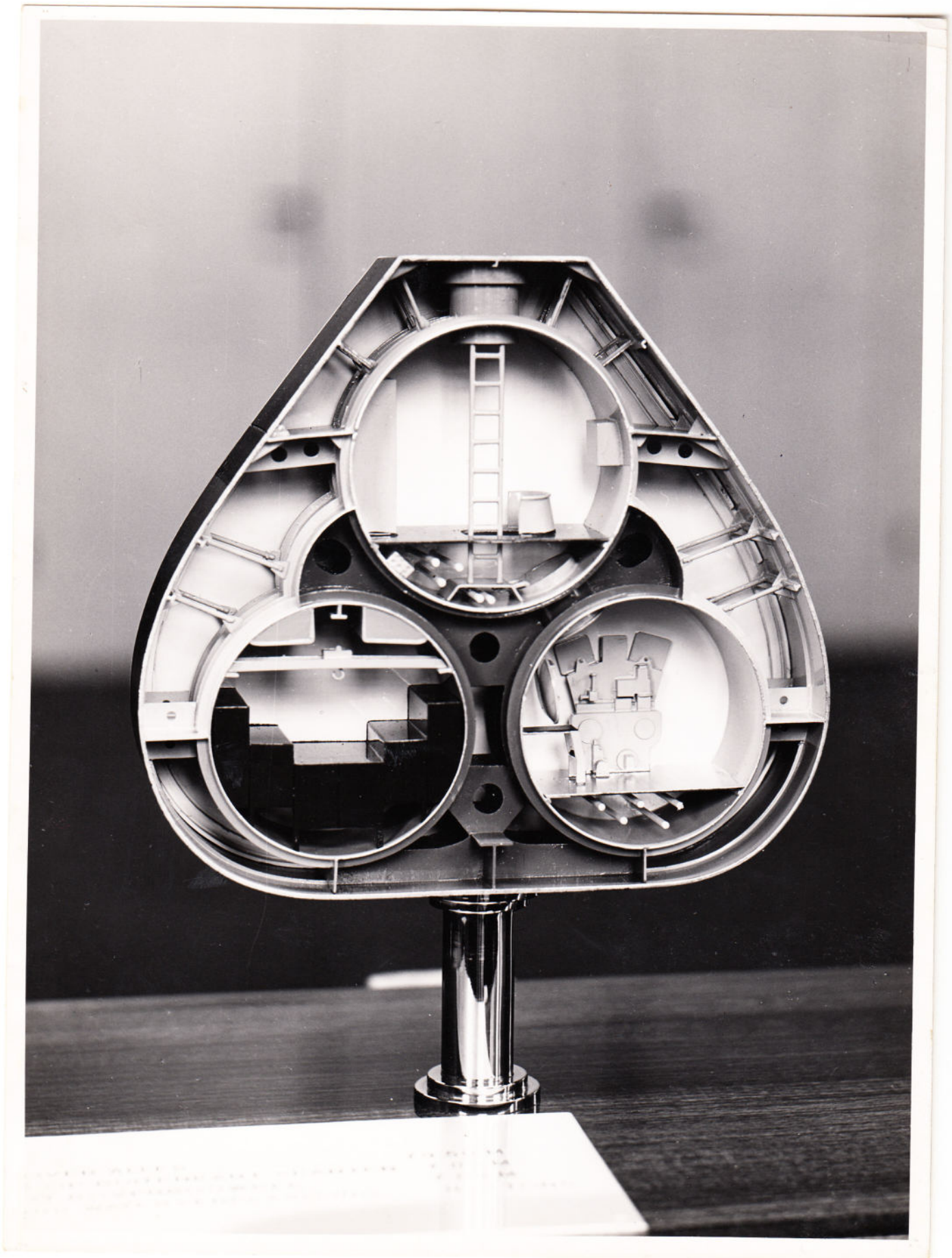
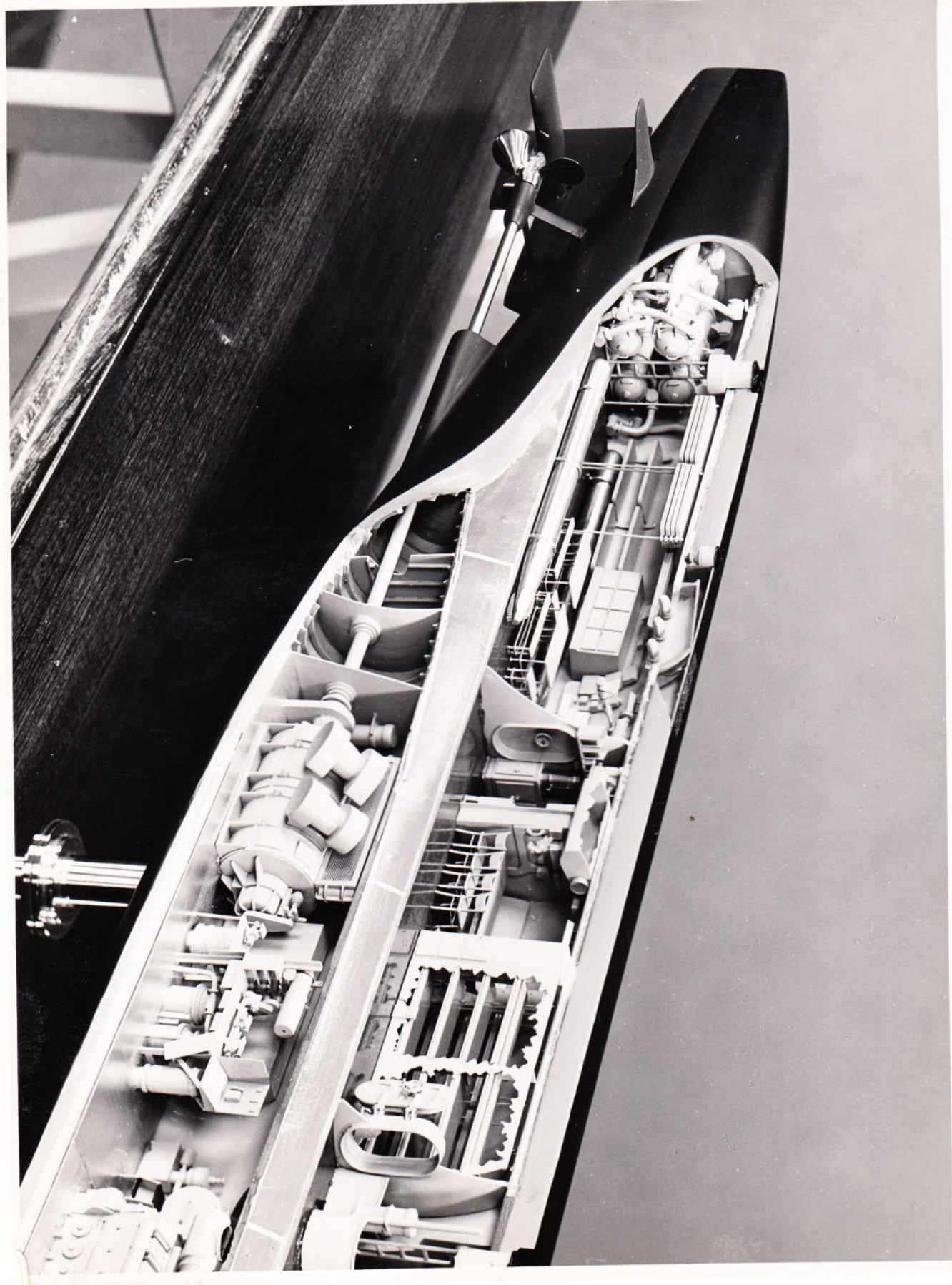
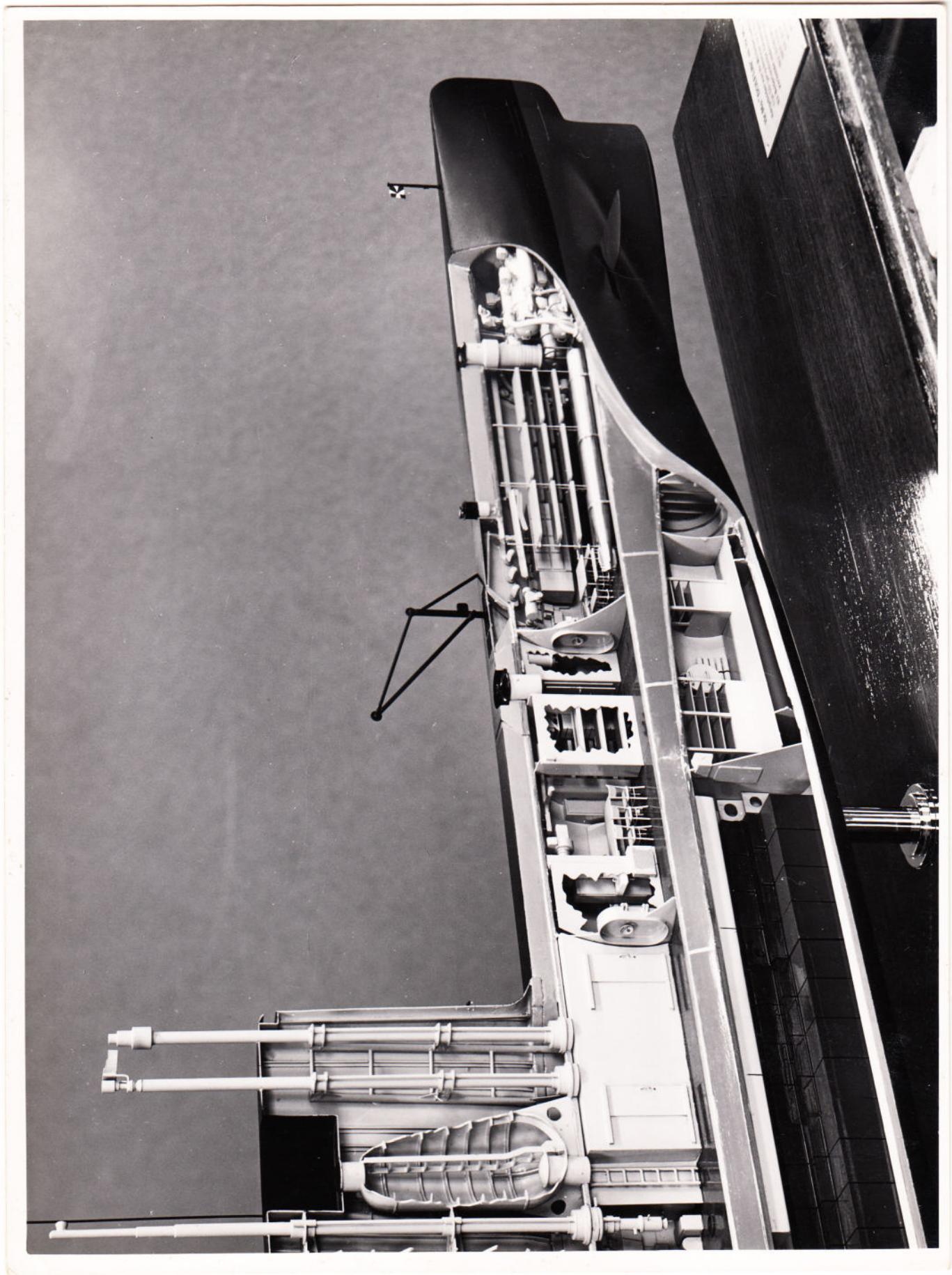
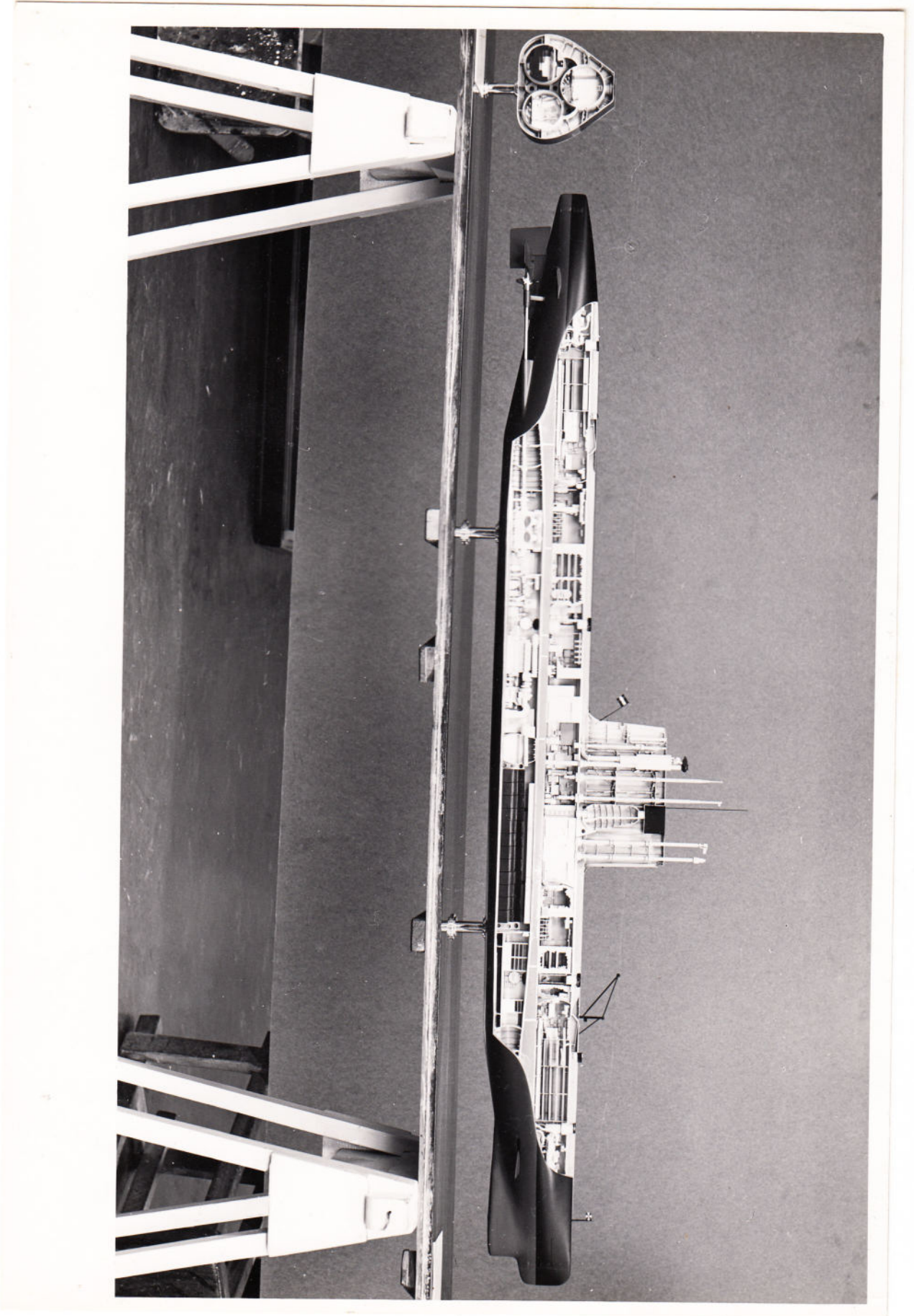

FIG. 1. A cutaway view of a complex, multi-chambered mechanical component, possibly a turbine or engine part, showing internal structures and components. The component is mounted on a vertical metal stand.









PSTUIS
1966

INSTRUCTIE MODEL ~~REDA~~ ROTUIS 1966





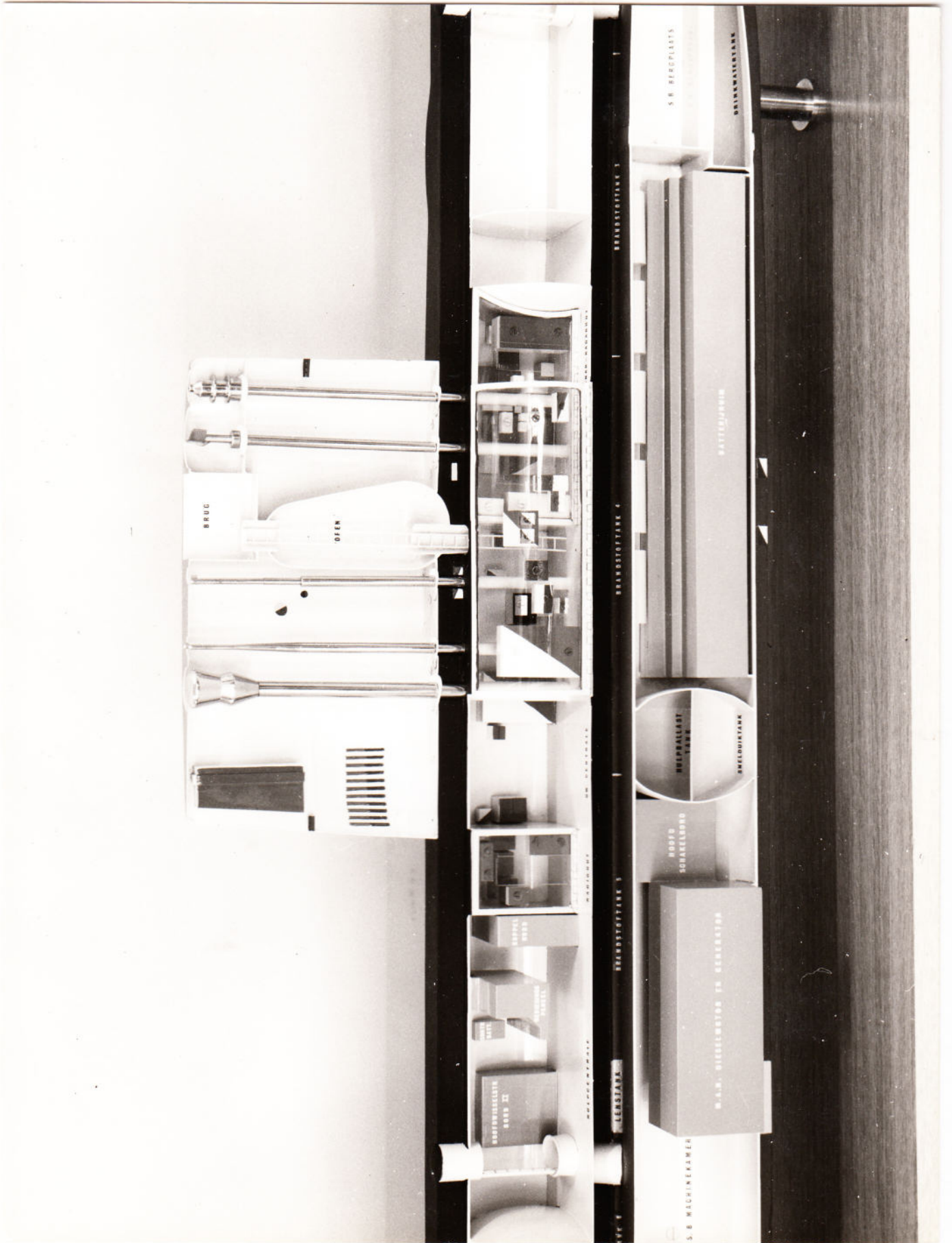





ZWAARDUIS

1972

1:50

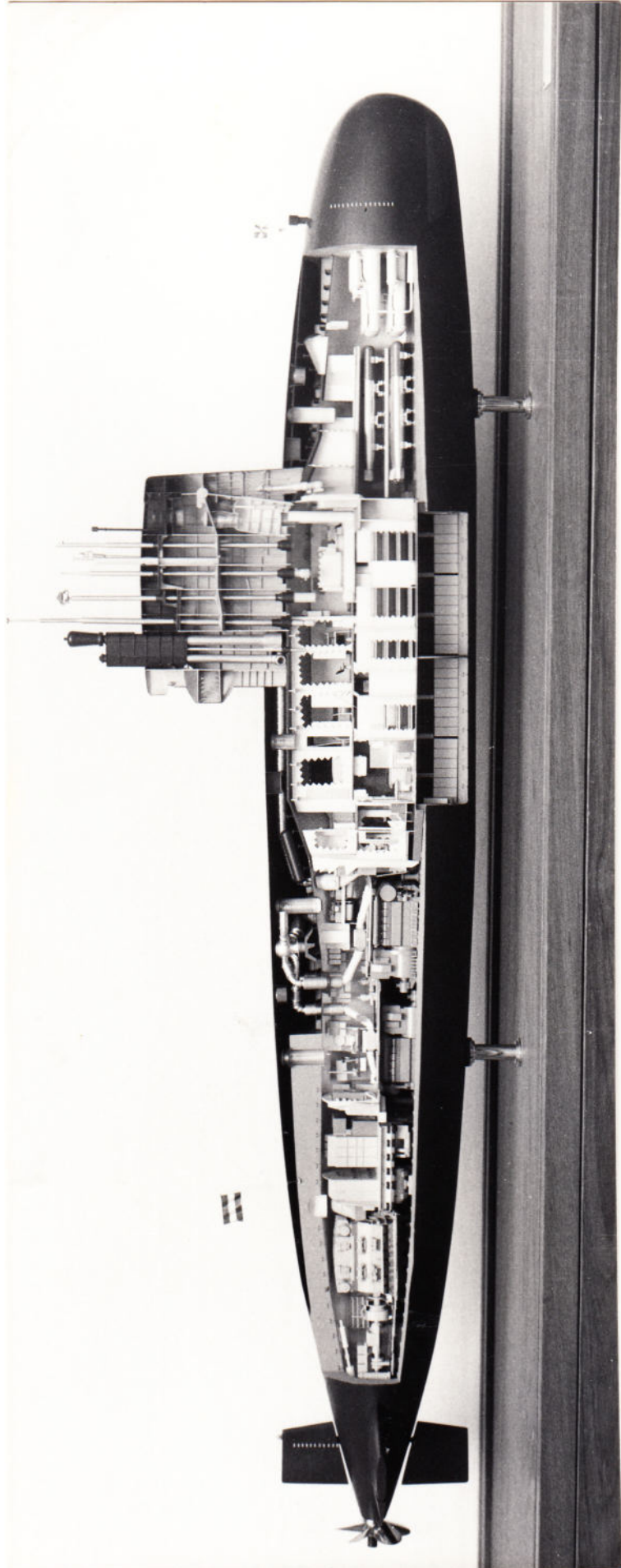

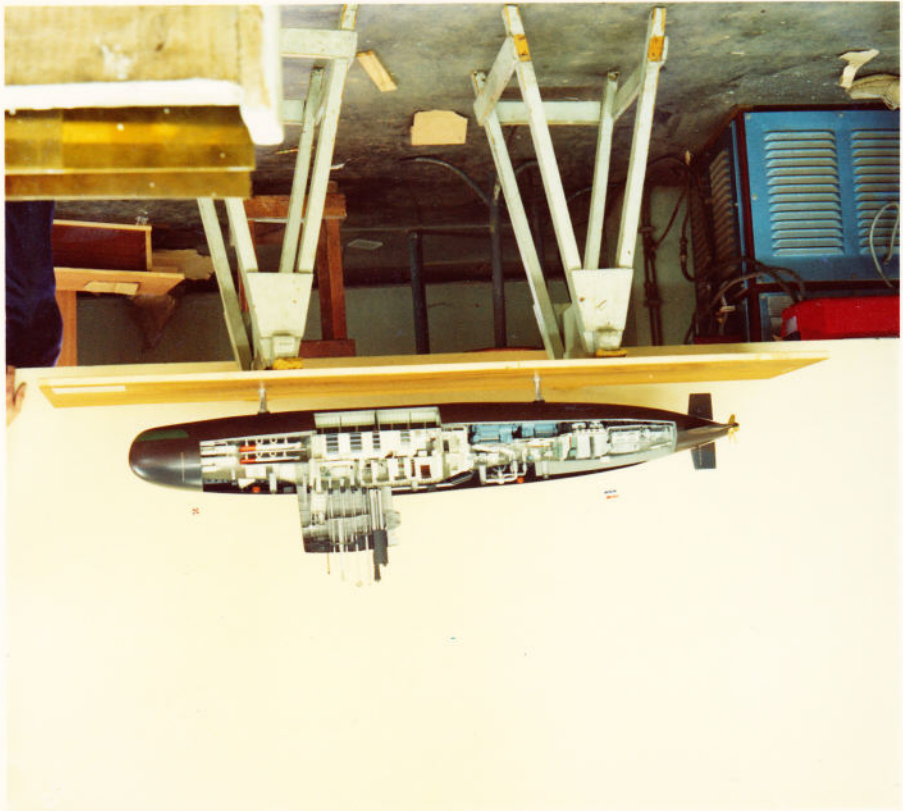

1972

ESMARDVIS

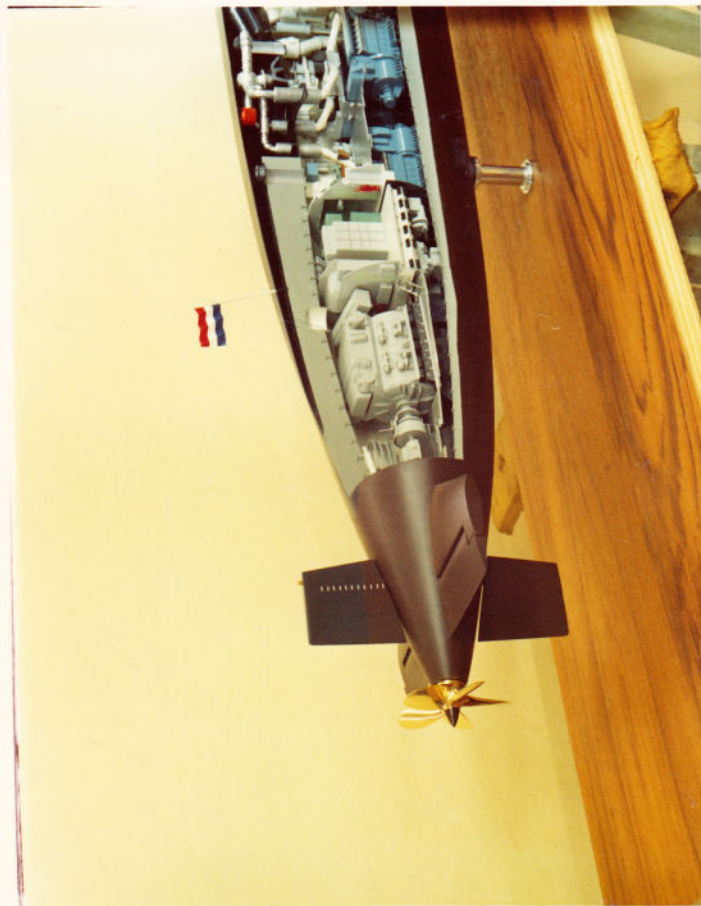
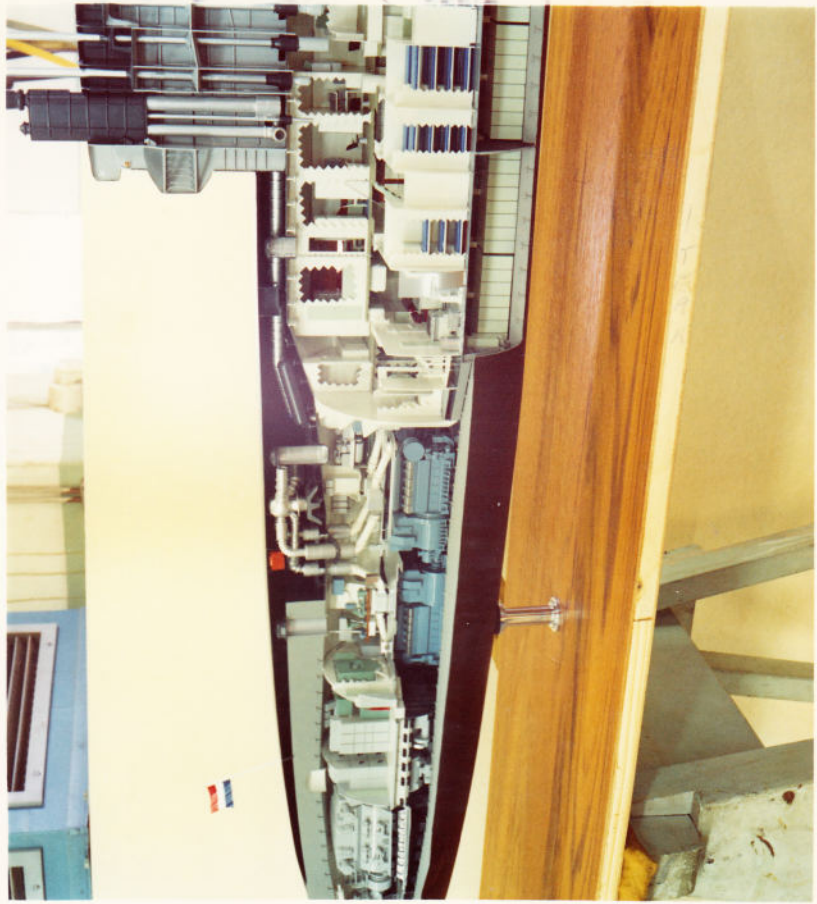
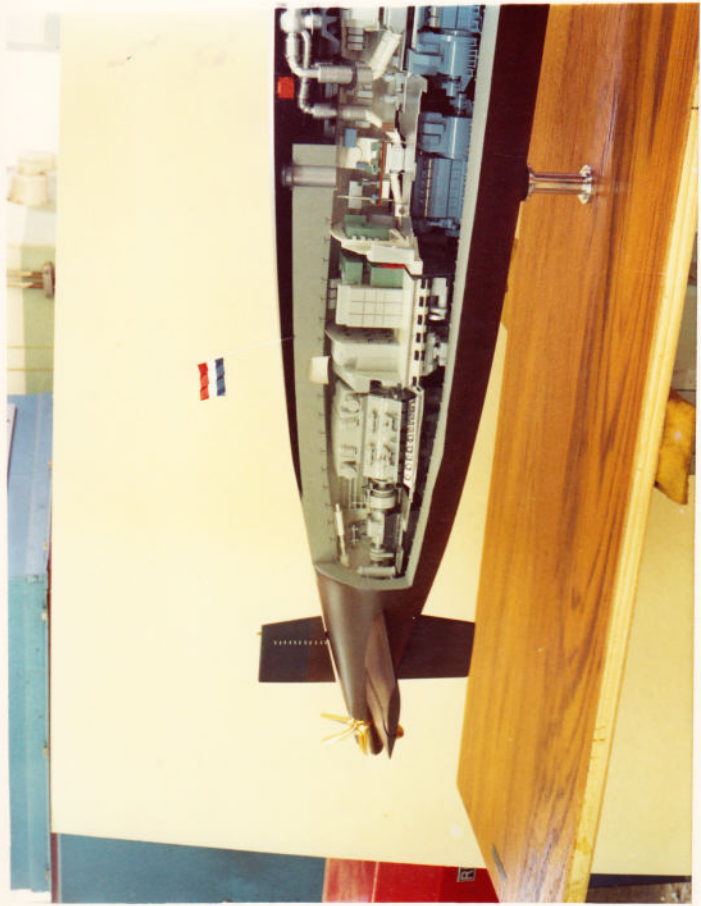

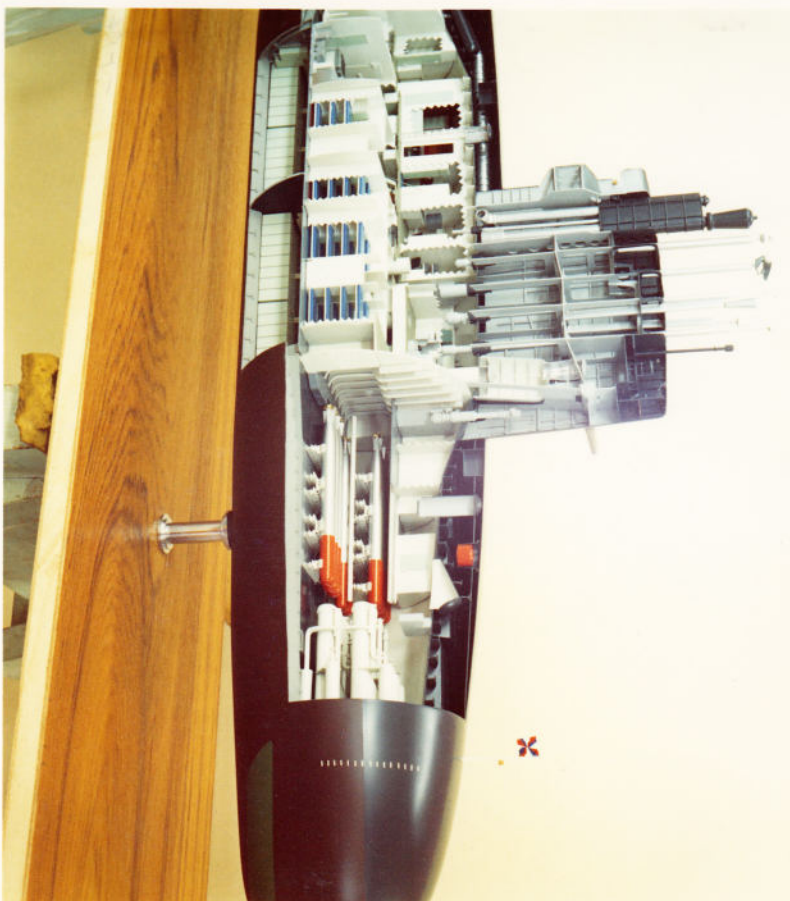
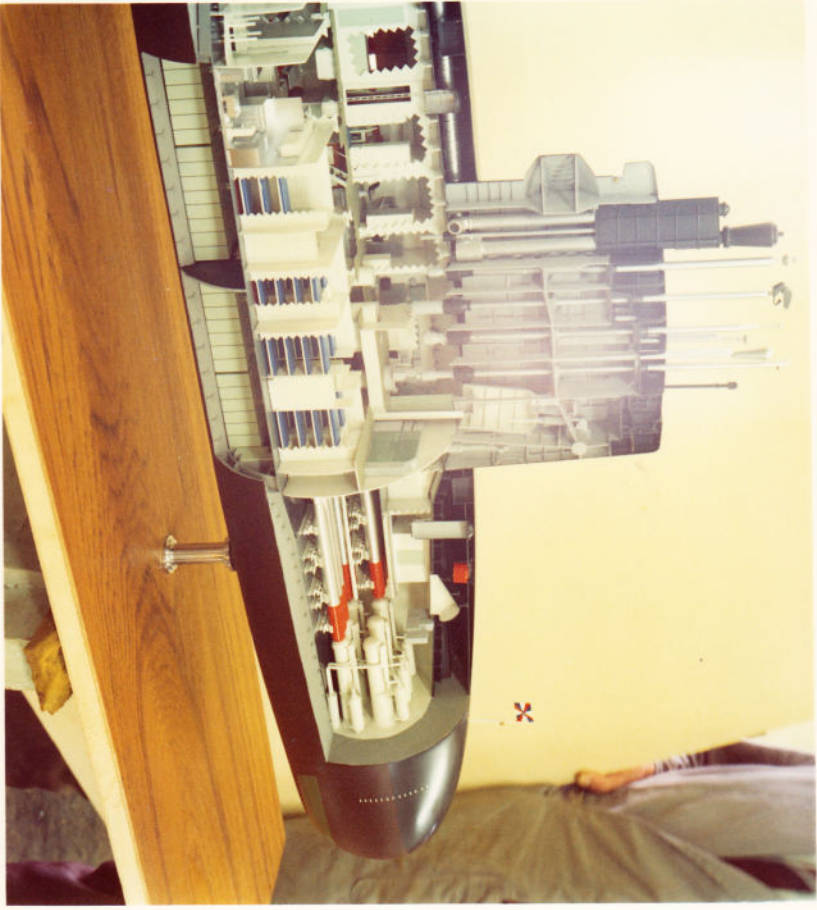





1100



1800



1400

1800

2x MORA 1100
 2x MORA 1400
 2x MORA 1800 + mod. 1.100
 15/12/85
 2 1/2 cur.

 3x MORA 1400
 1x MORA 1100 + mod.
 16/5/86
 1.100
 95% cur.

 3x MORA 1400 + mod.
 7/6/85
 1.100
 104 cur.

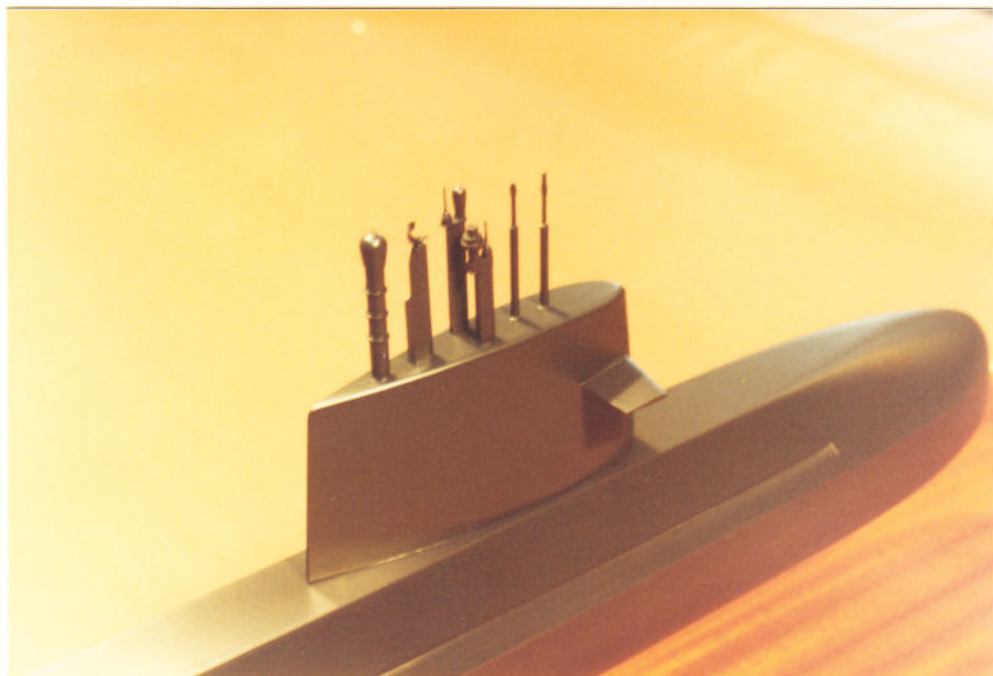

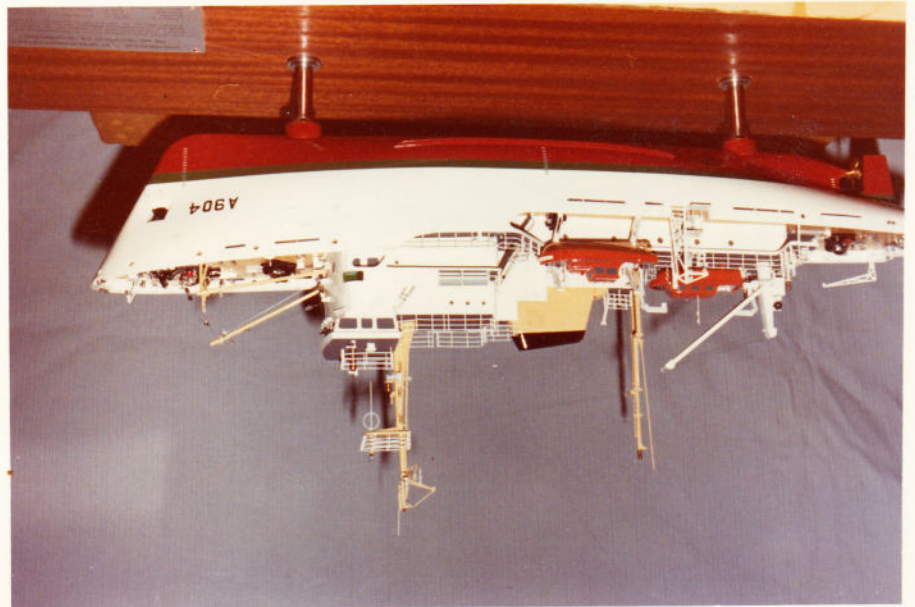
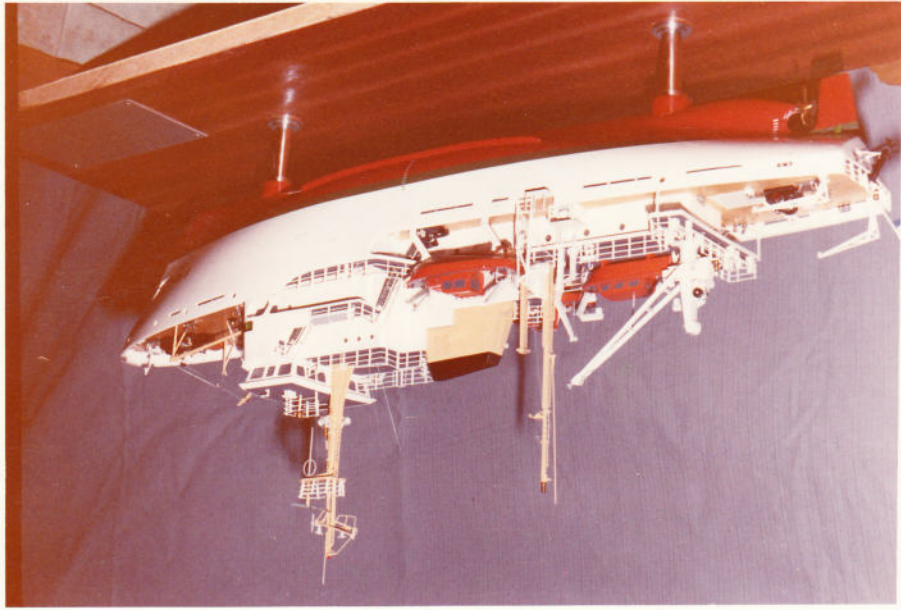
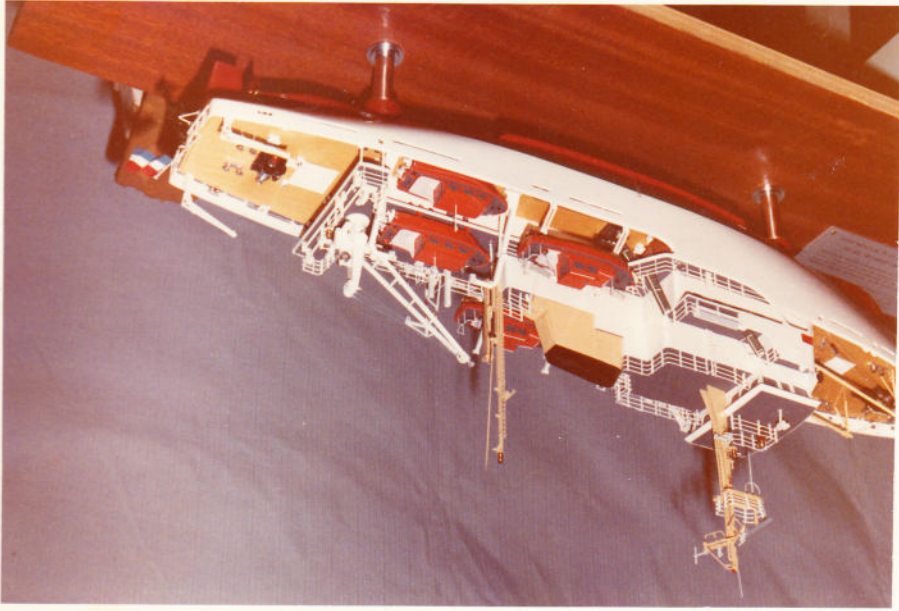

1973/74
Petersen
2
Beck's lens
Sprung v.



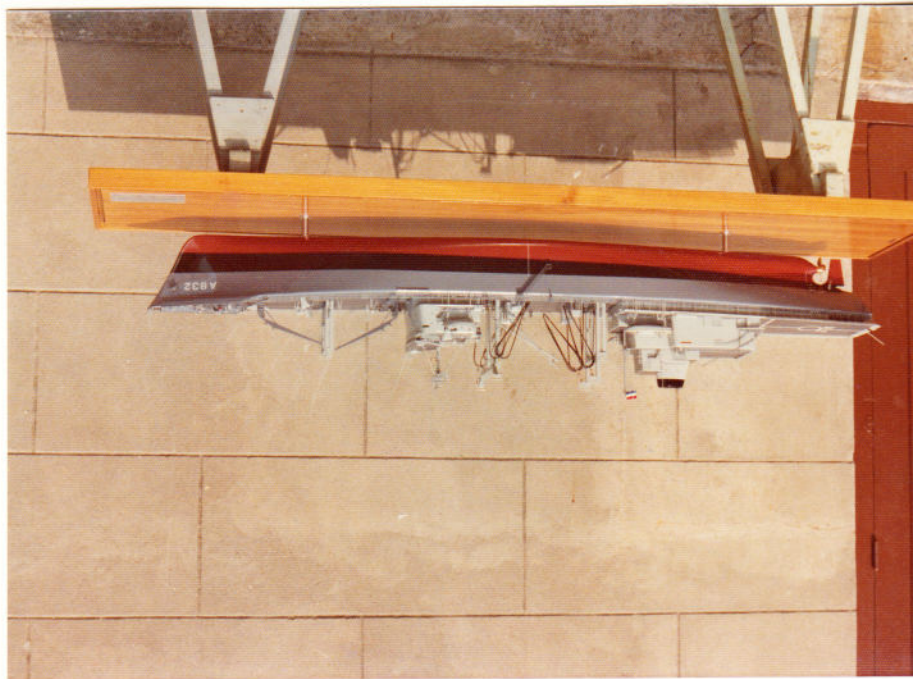
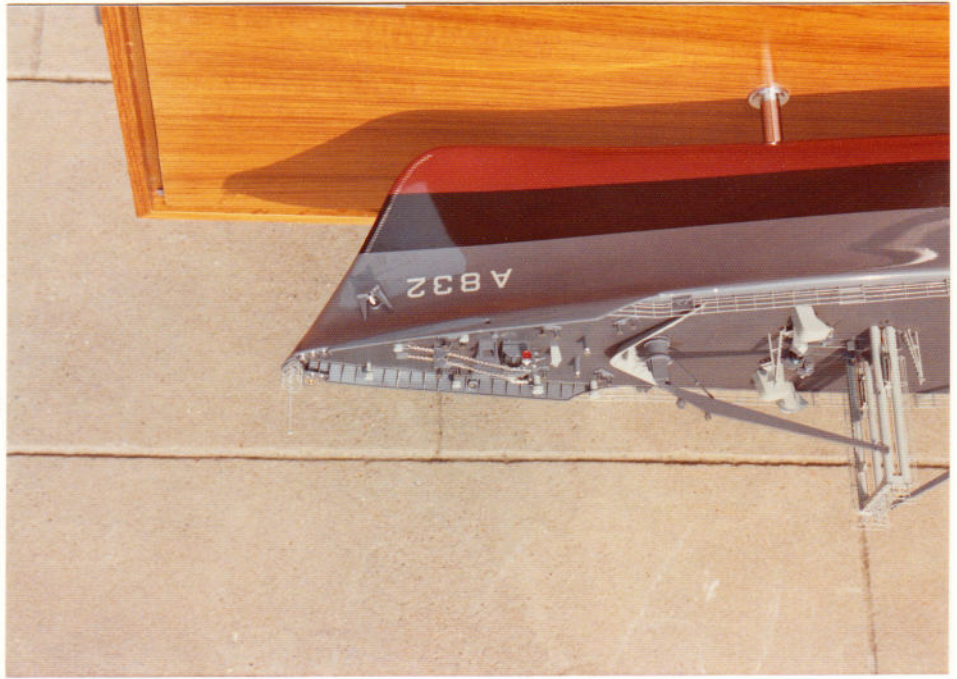
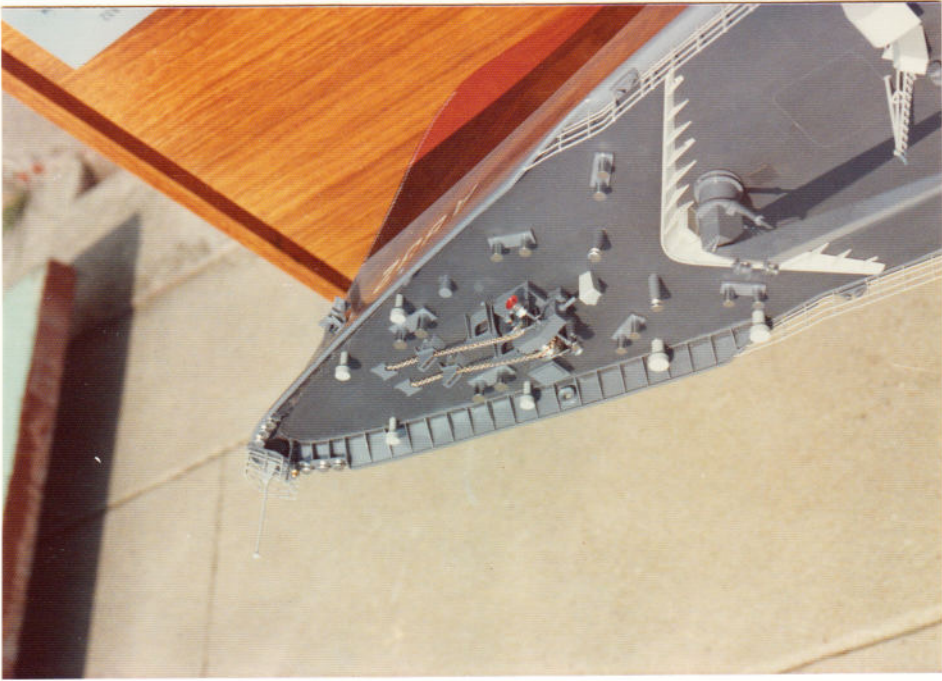

Guide lines
 here faint
 840 was
 for 97

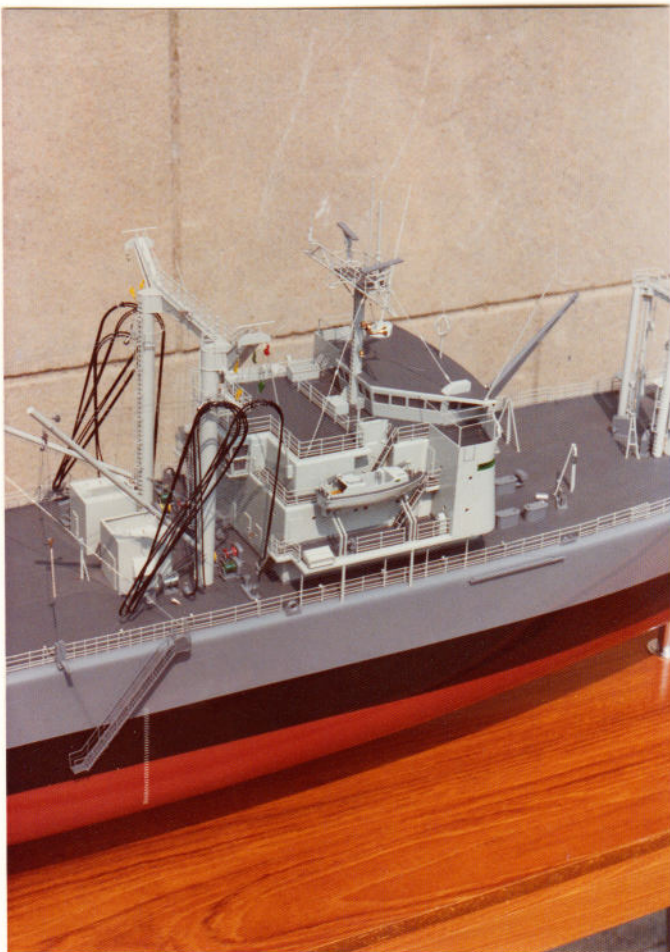
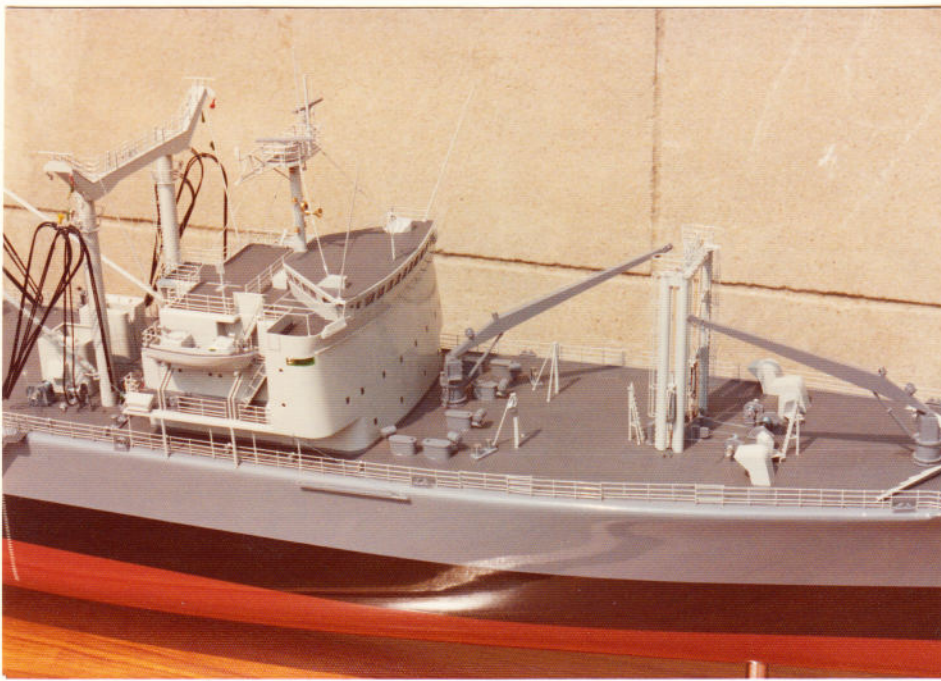

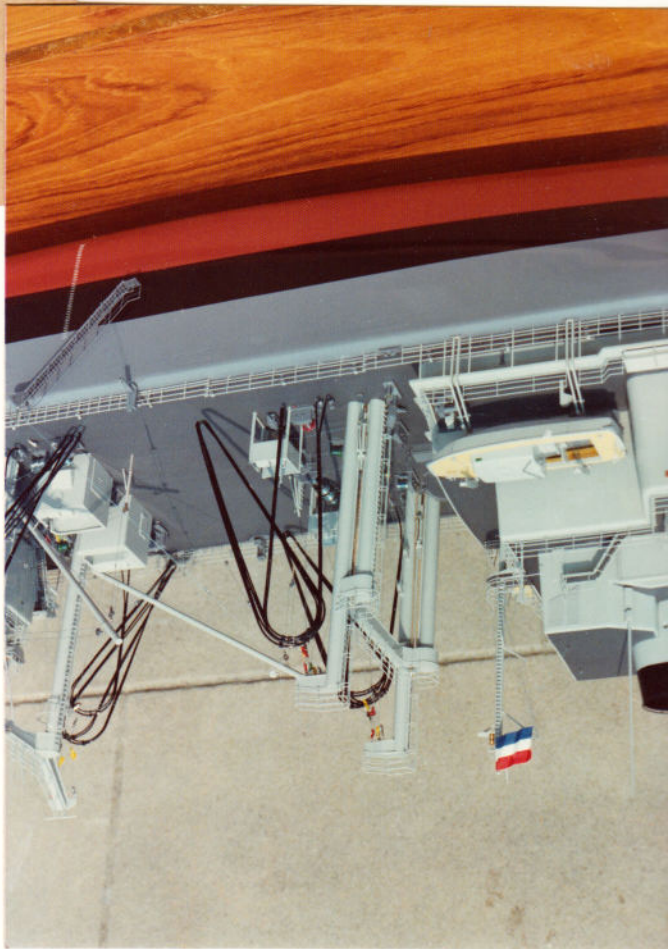
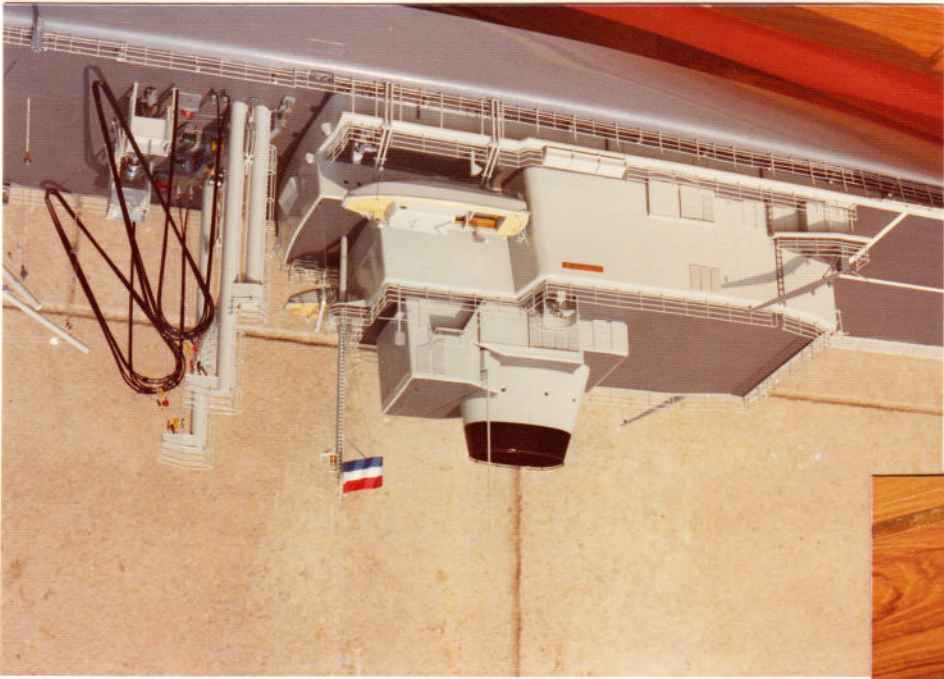
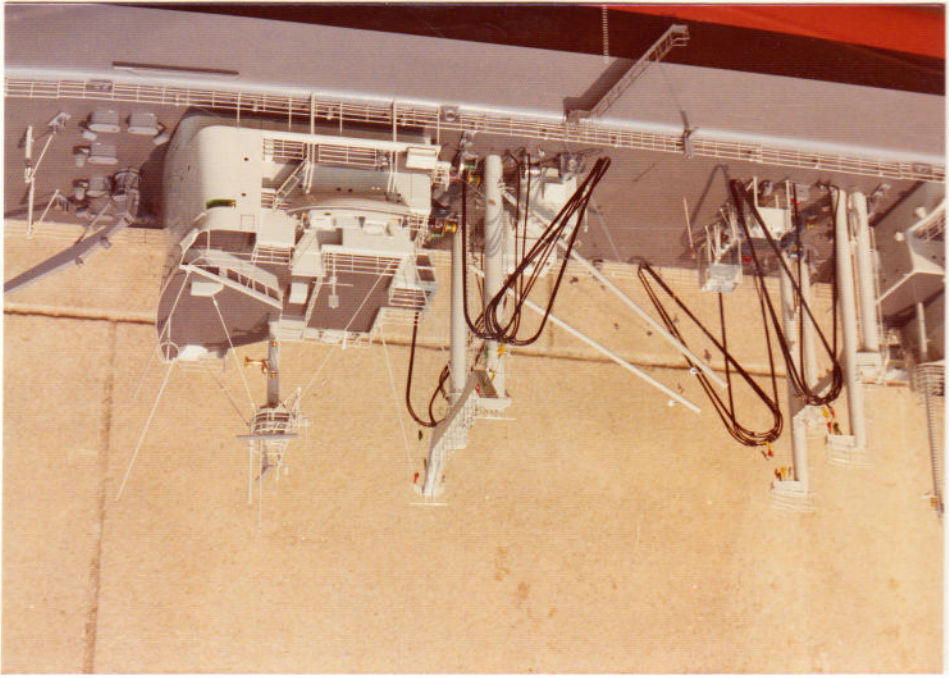

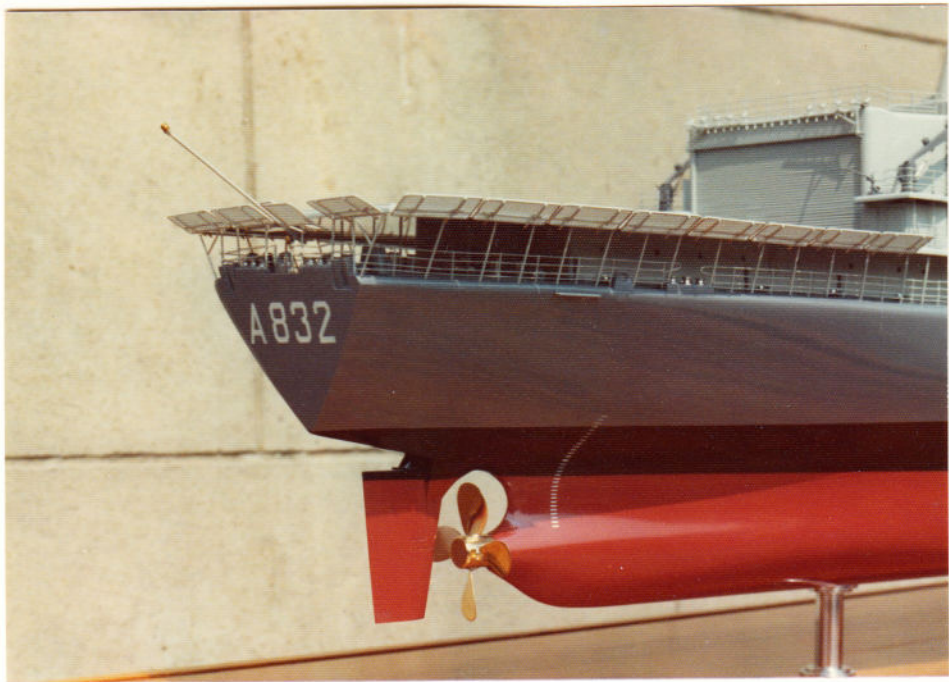
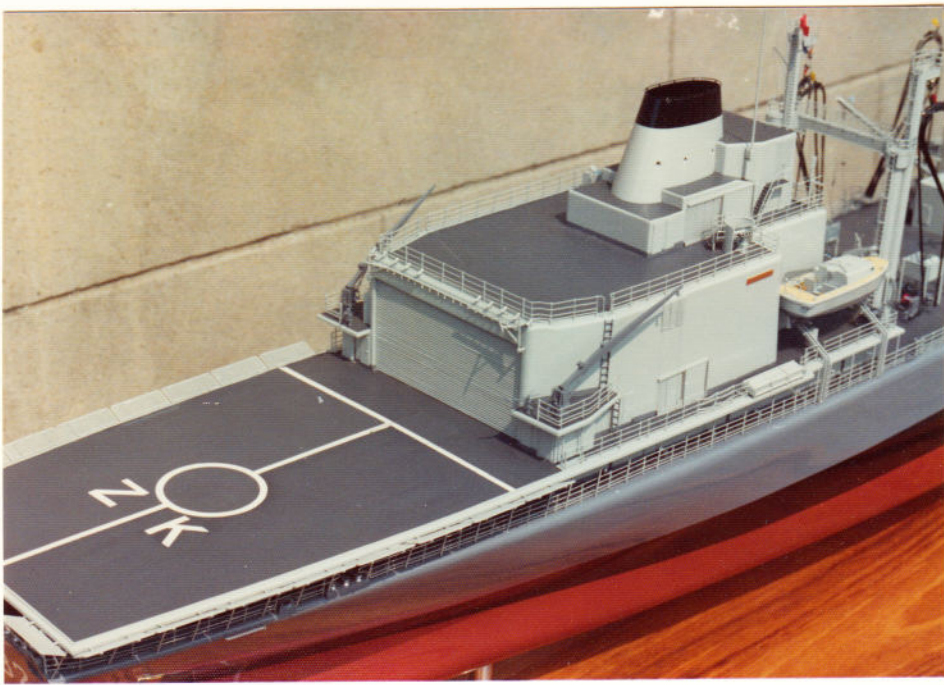

"AMSTERDAM"

SCHELDE

1:100

bevoorradingsschip

166cm

7/4/97

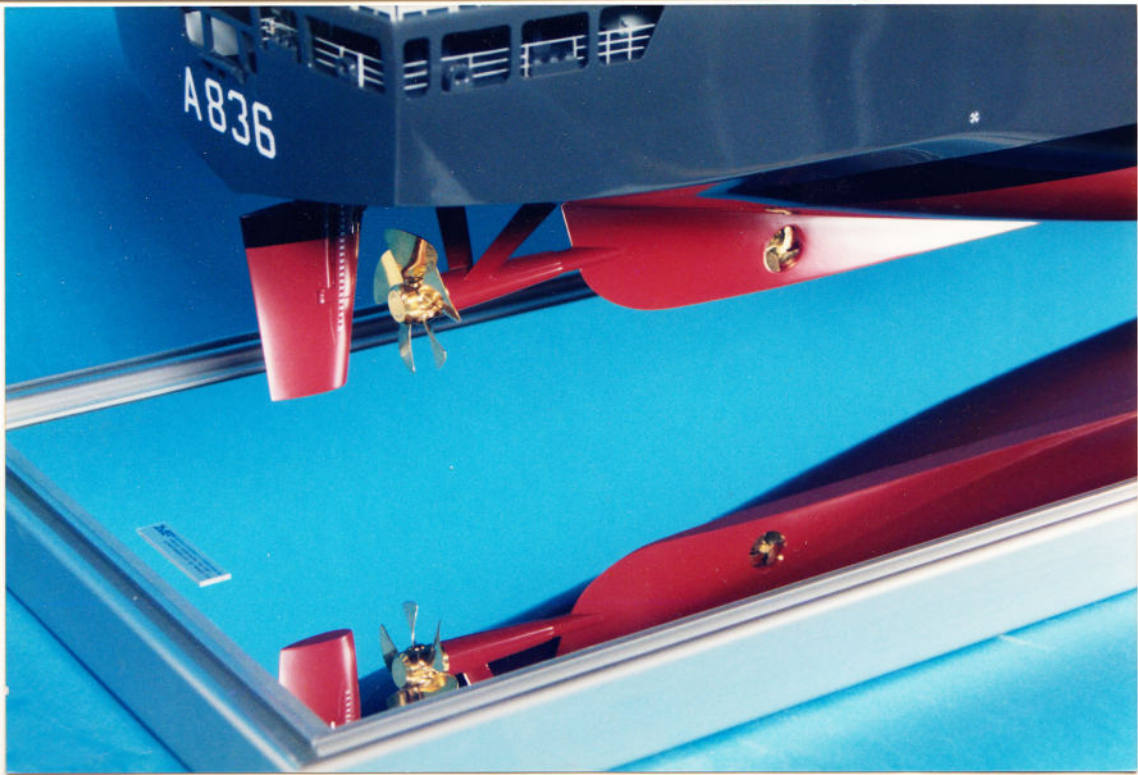

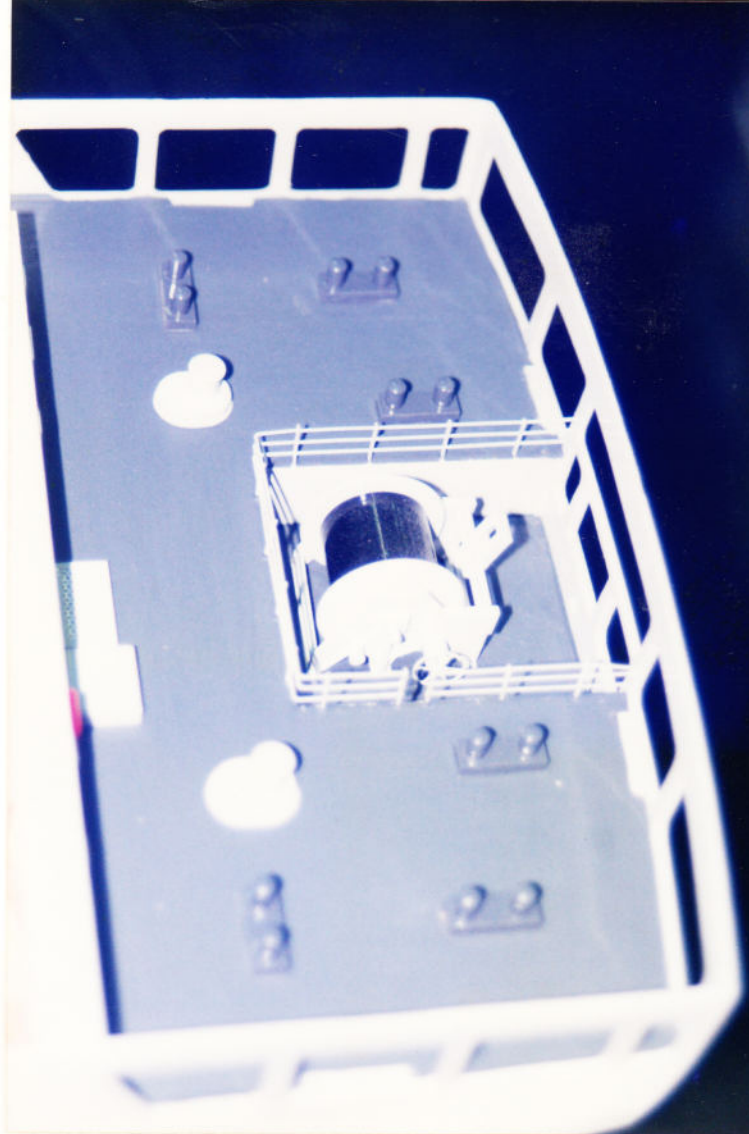
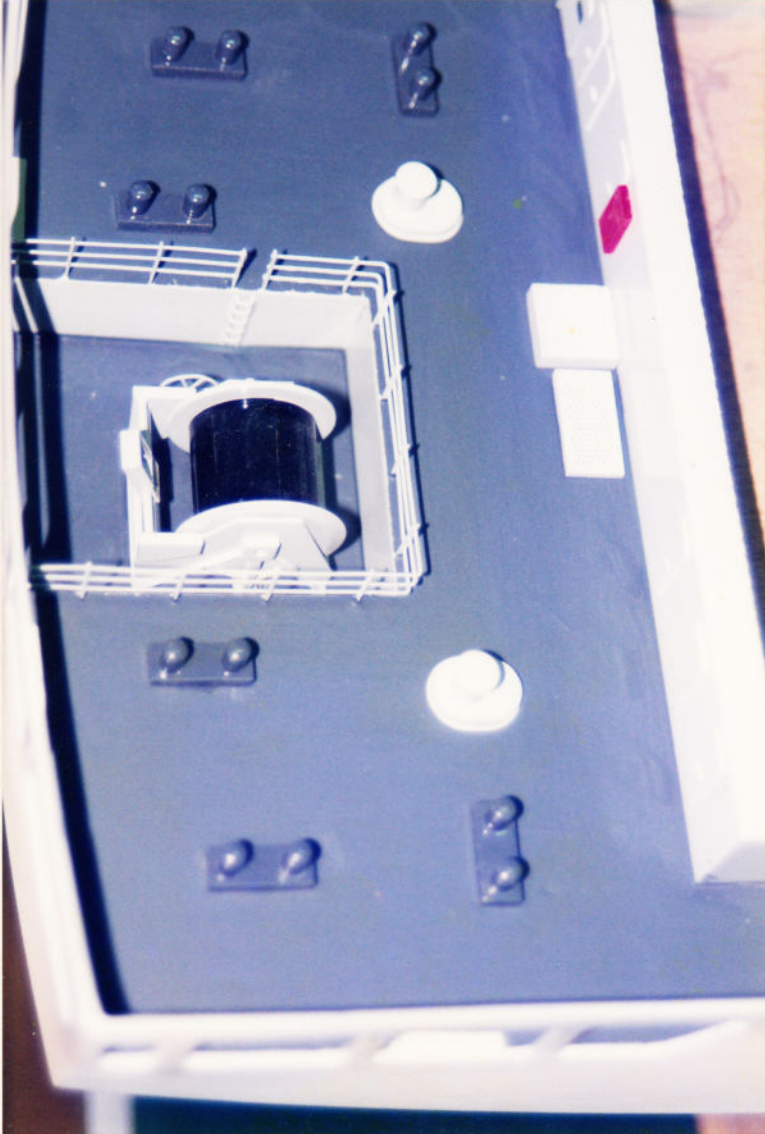

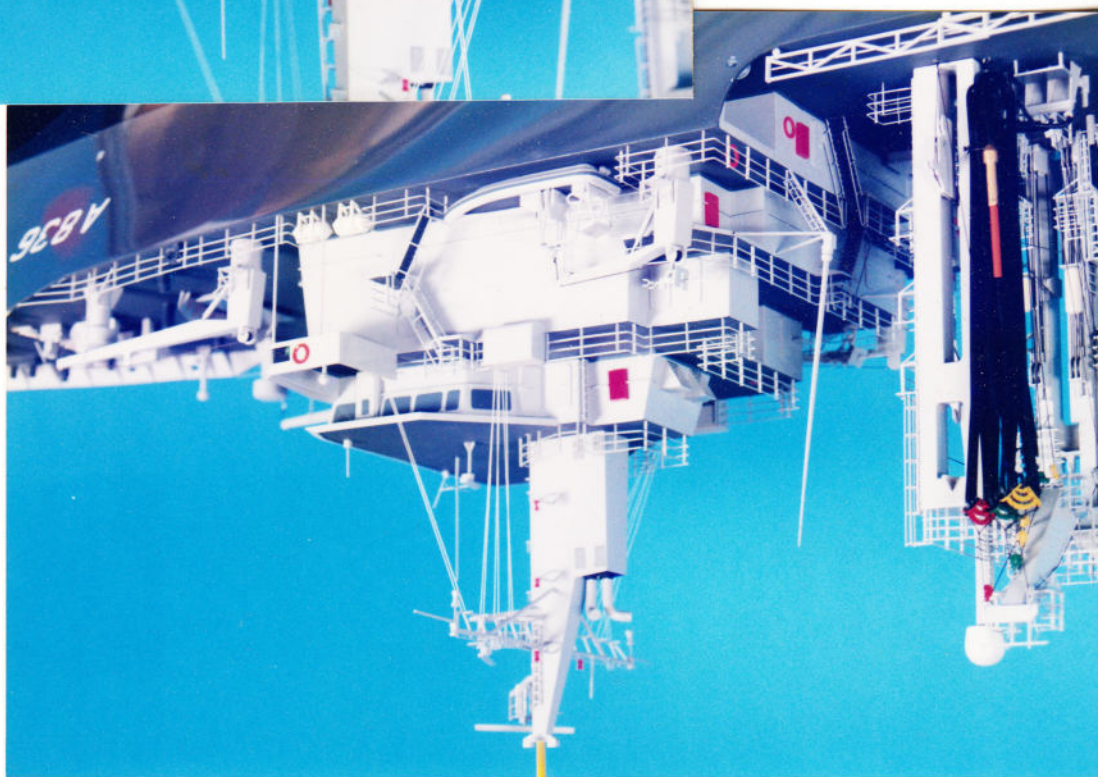
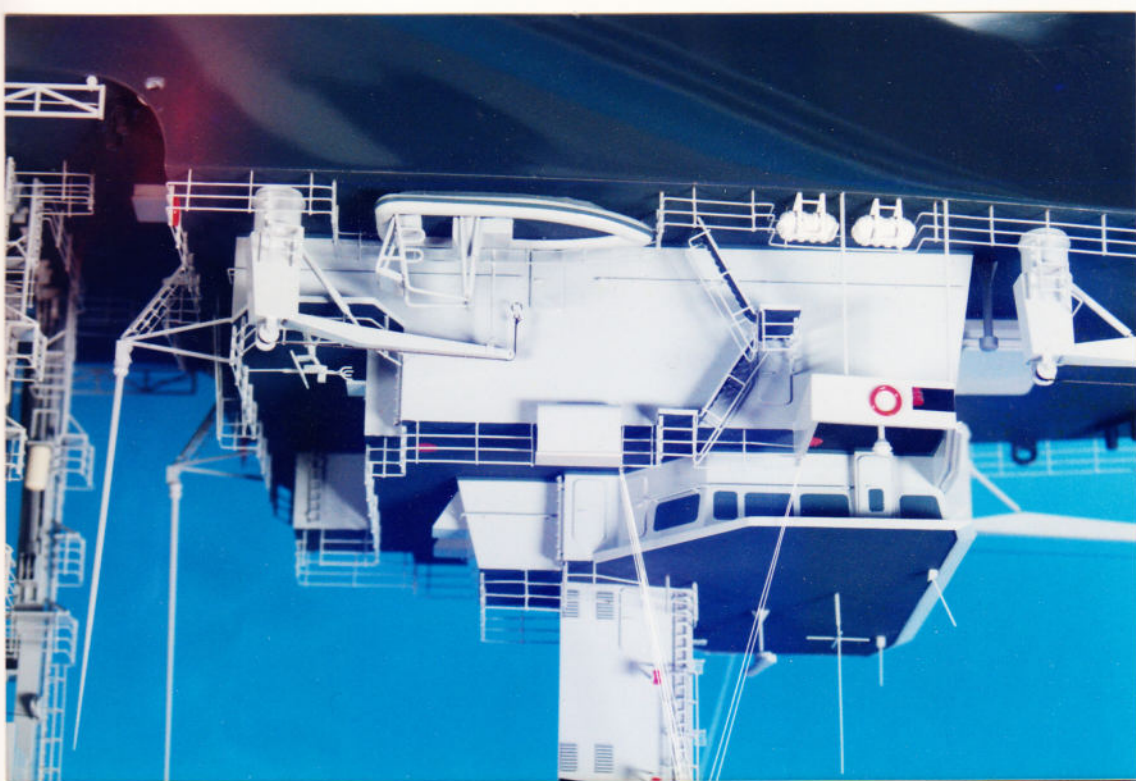



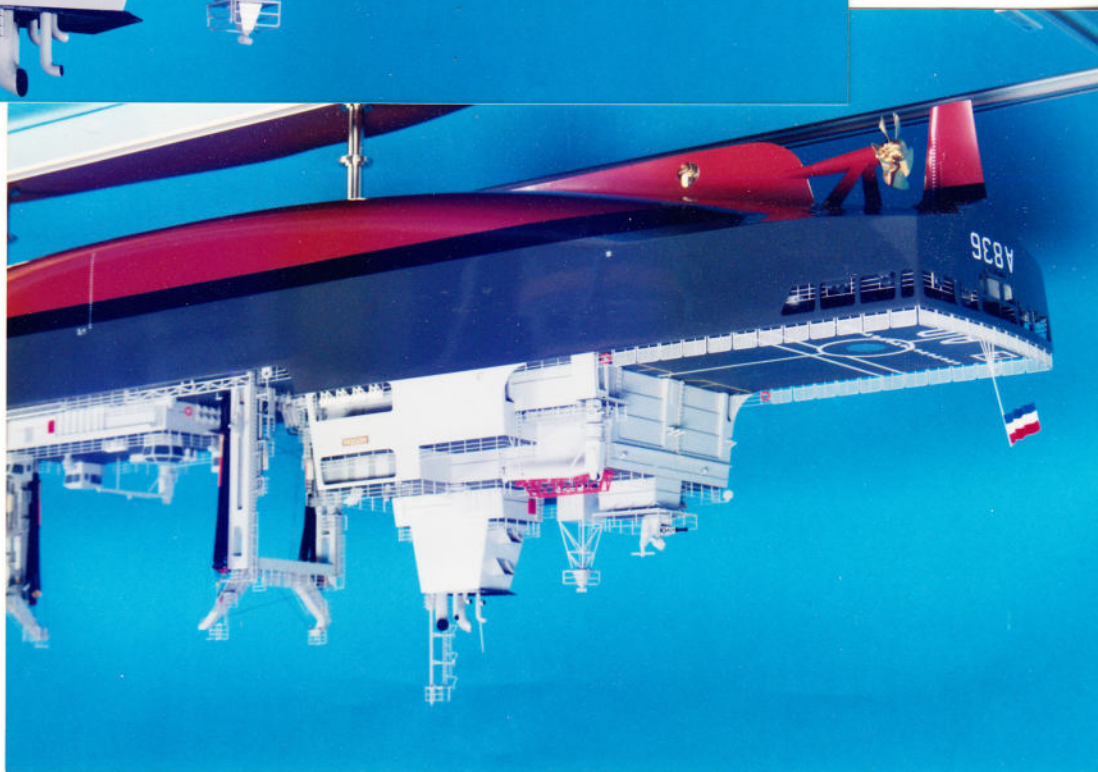
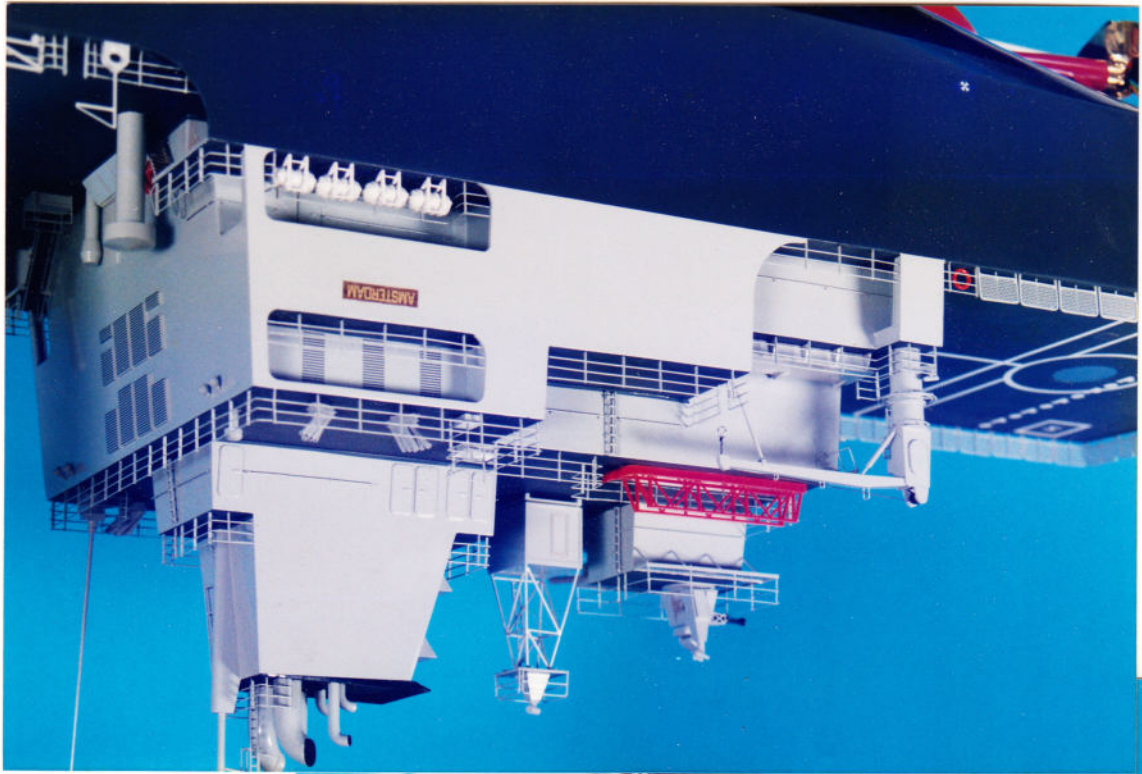
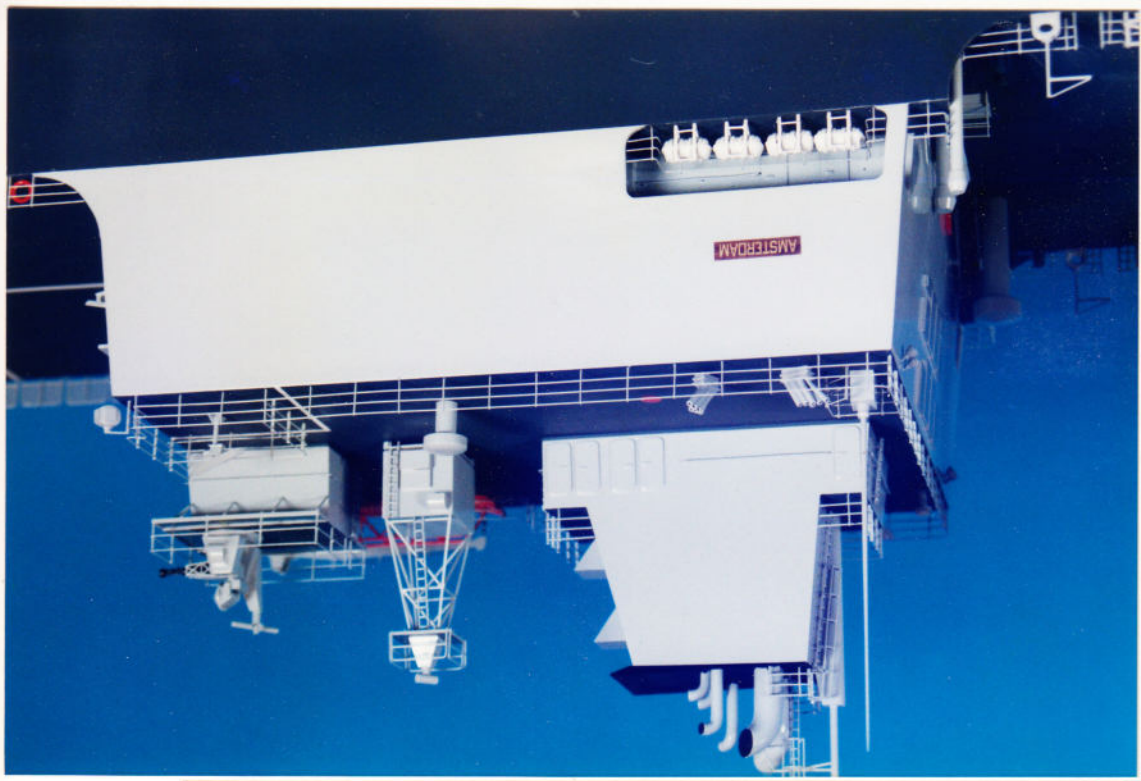

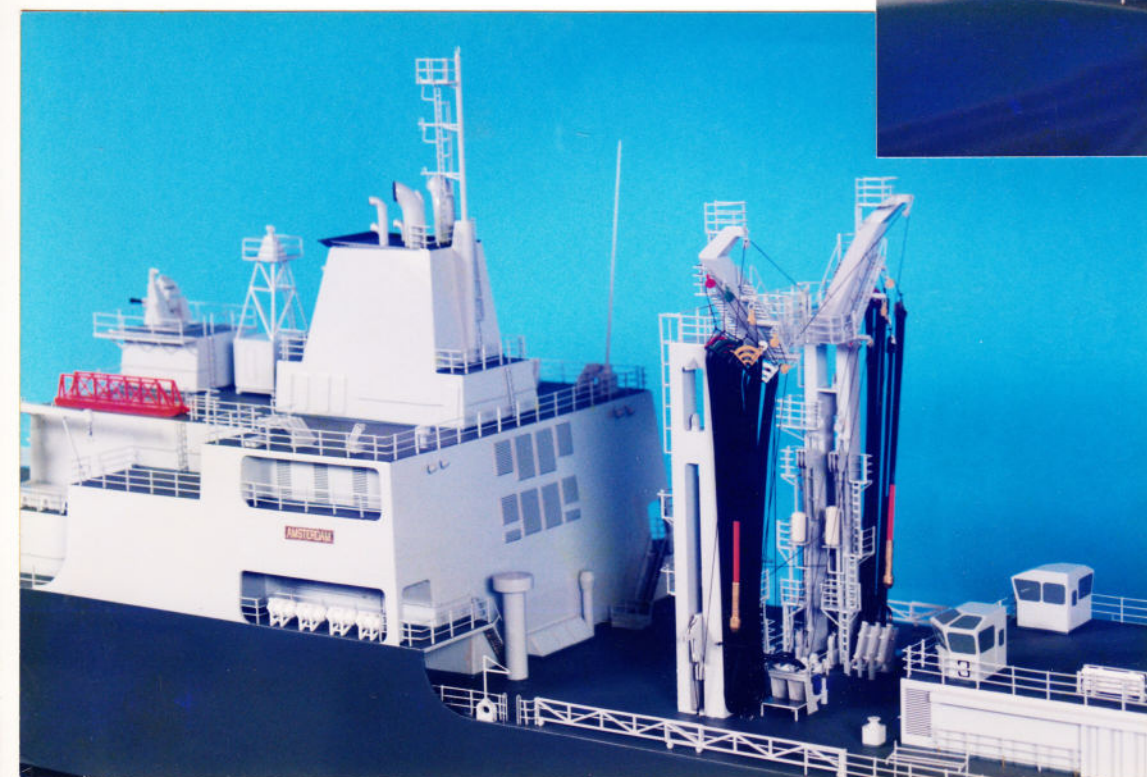

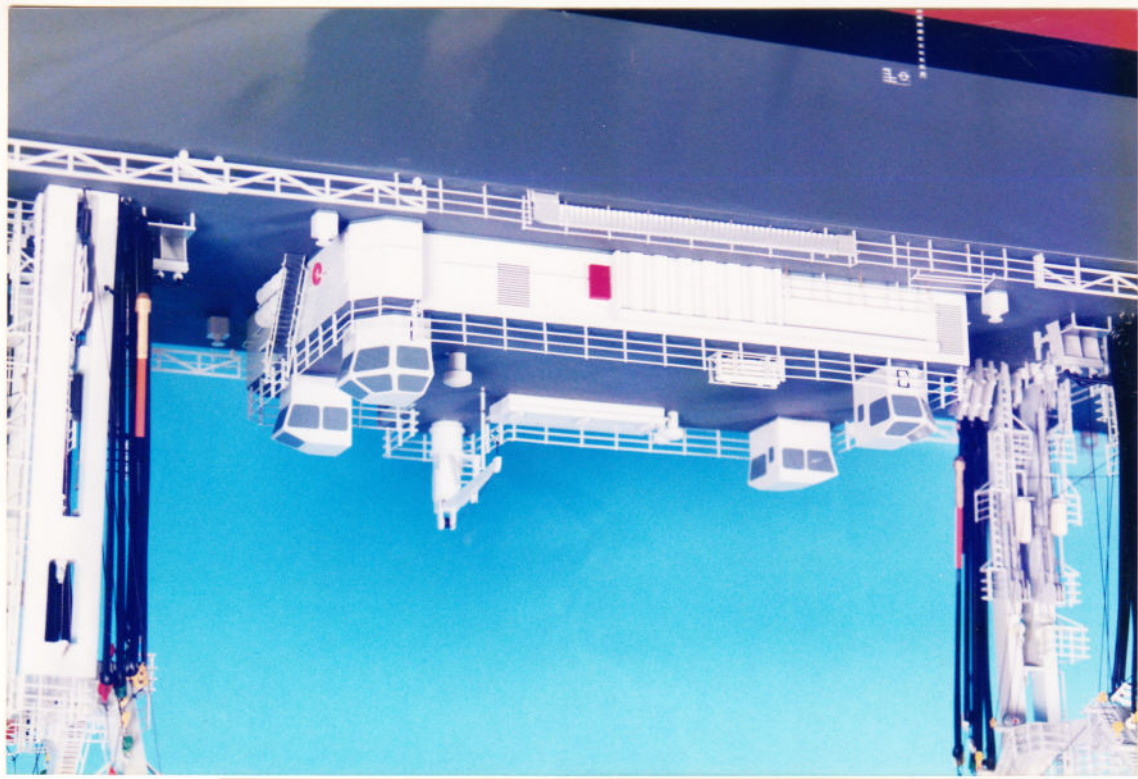

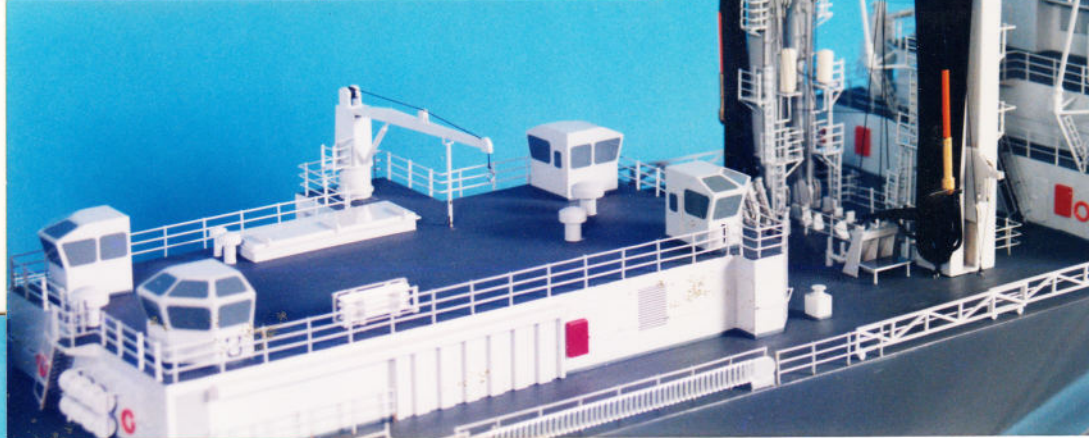
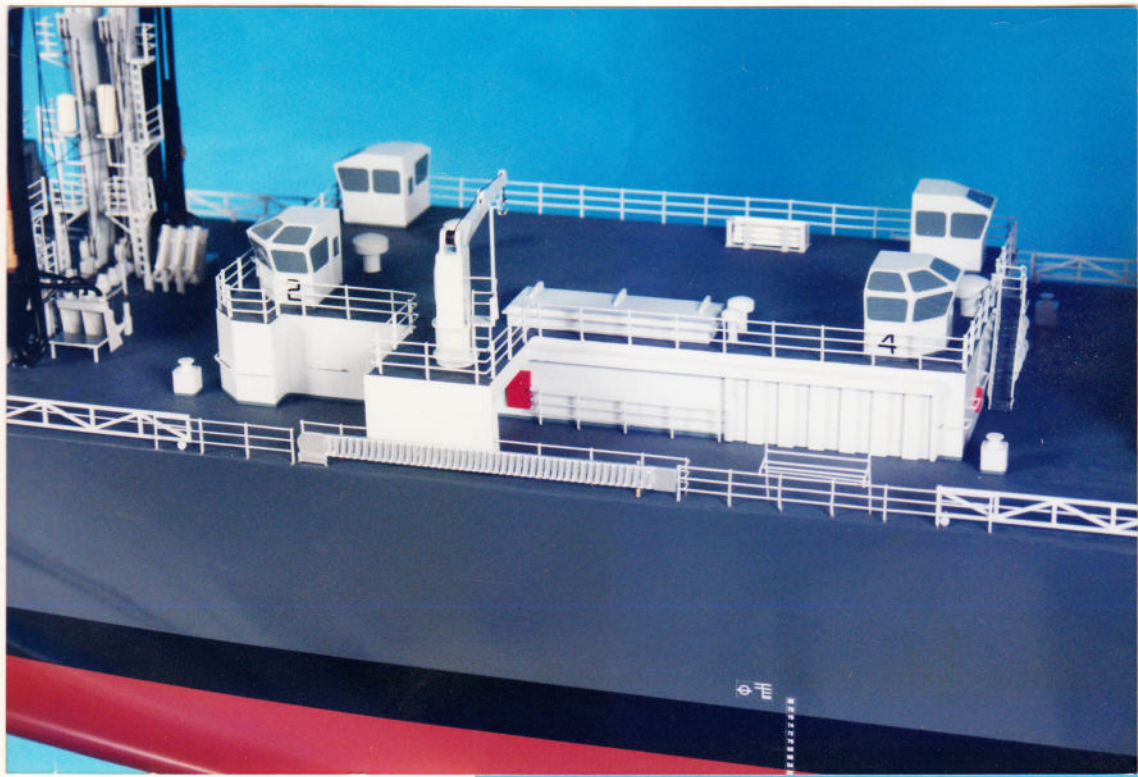

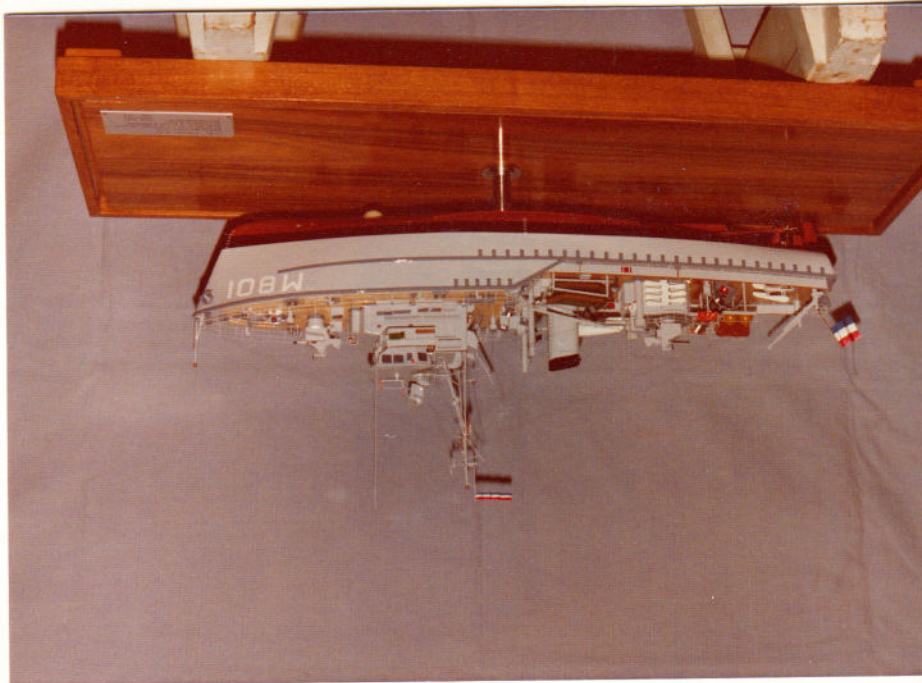
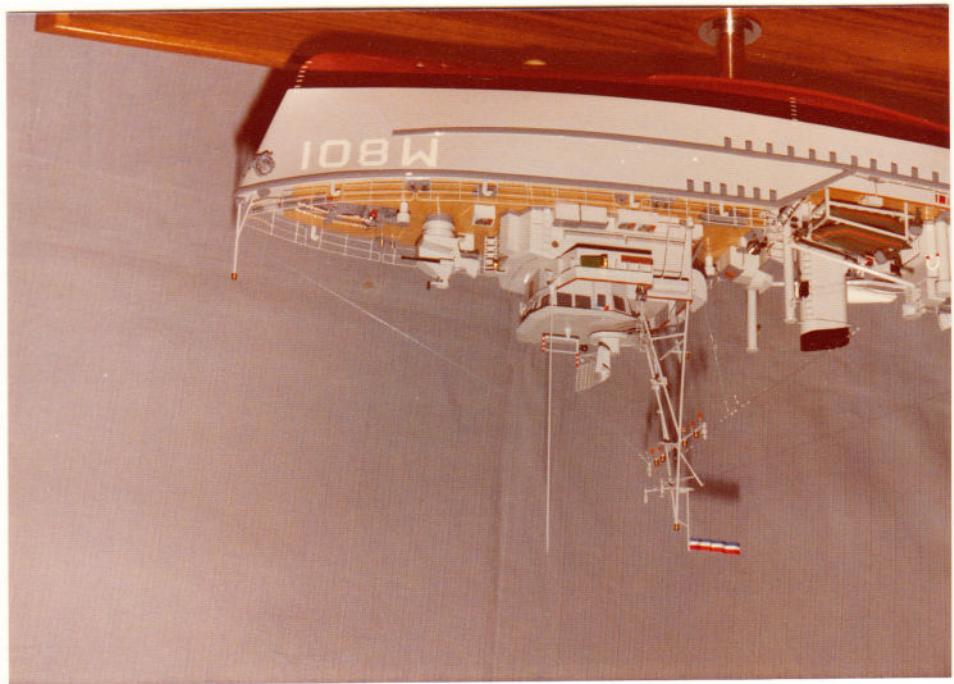
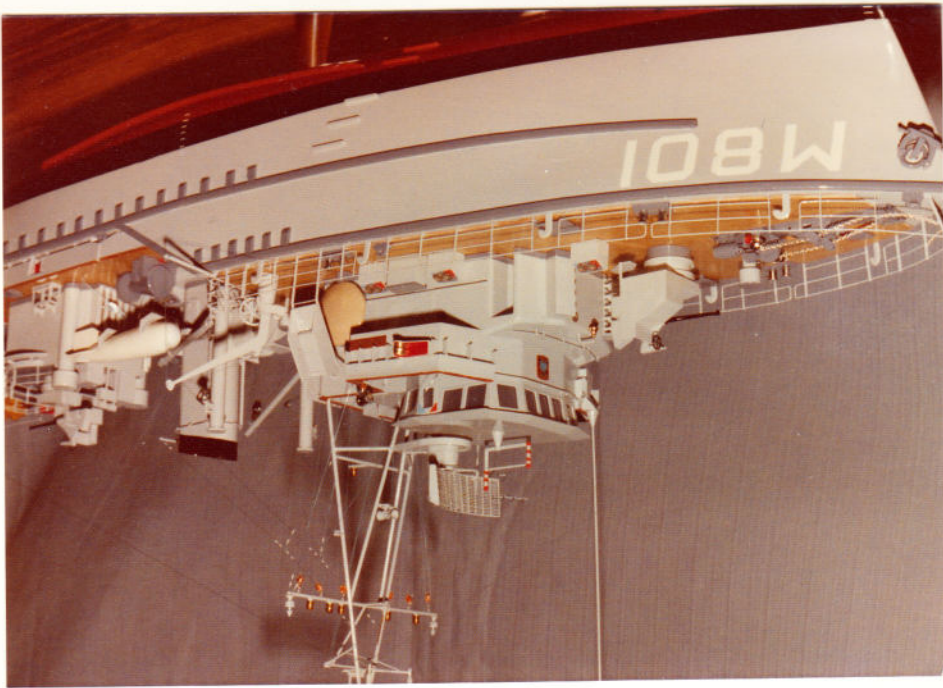

18
 2 STUKS 633 cm.
 1975.
 "DOKKOM"
 M. J. GIESSEN - DE WERF
 1975.



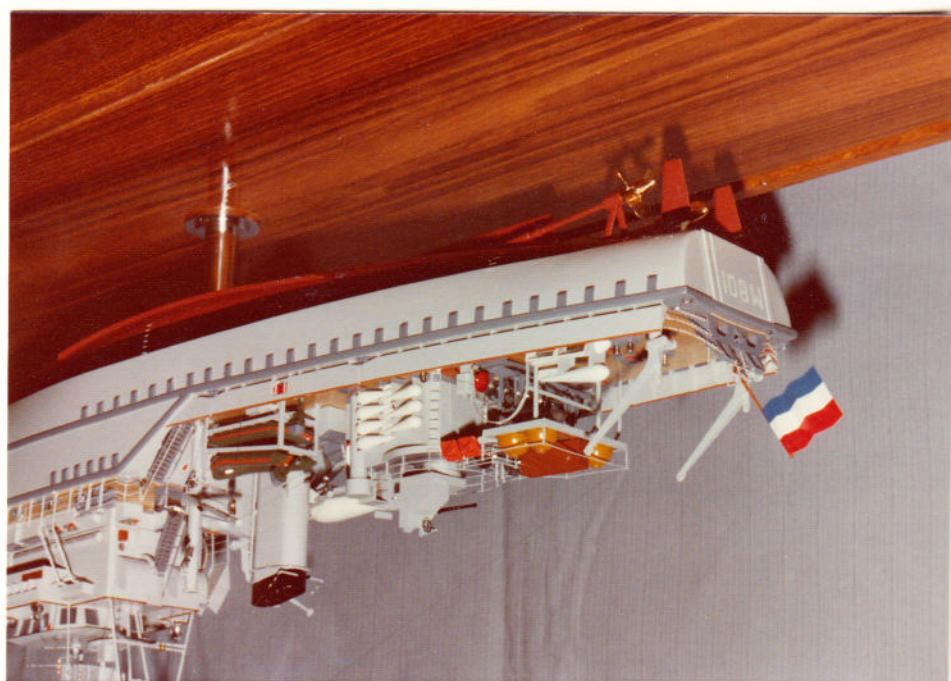
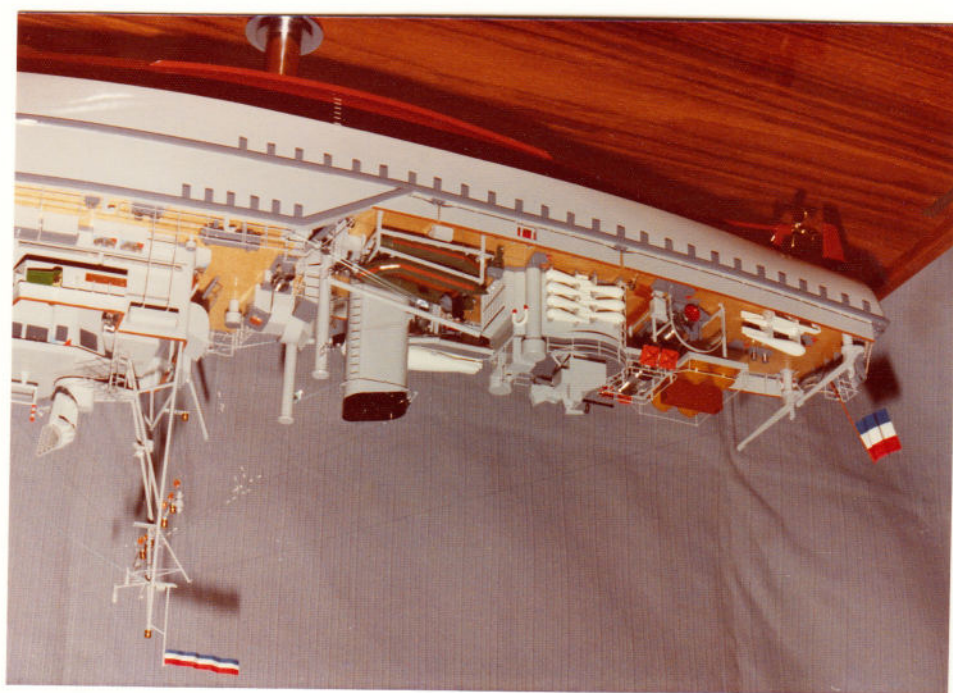
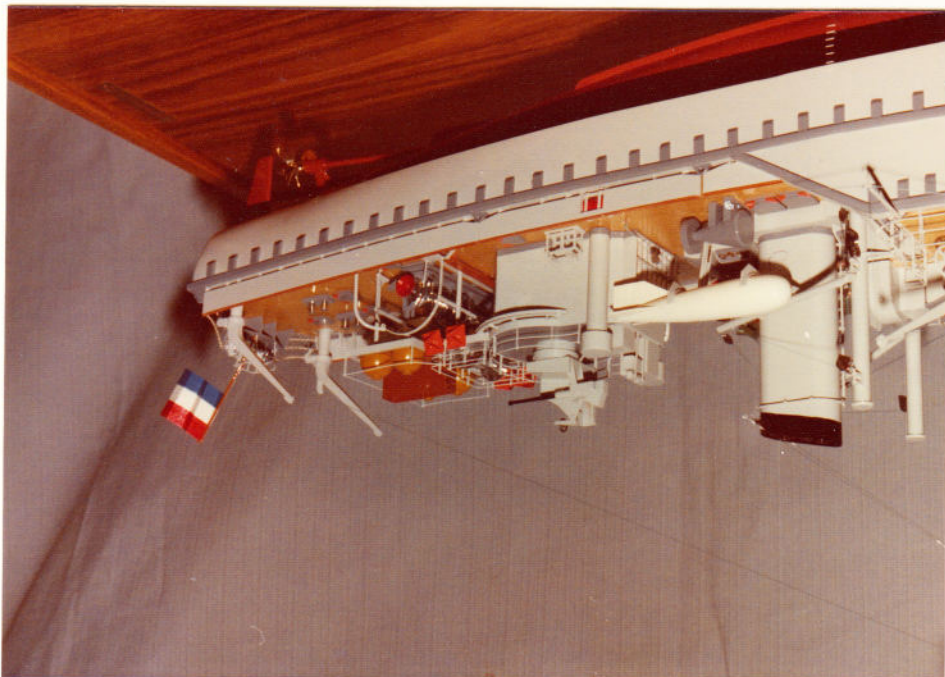

Ulf Björnsén - Sönder
MYNENÅGER
"DOKUM"
1175
OKTOBER 1974
14N
2 stuks 633 part.

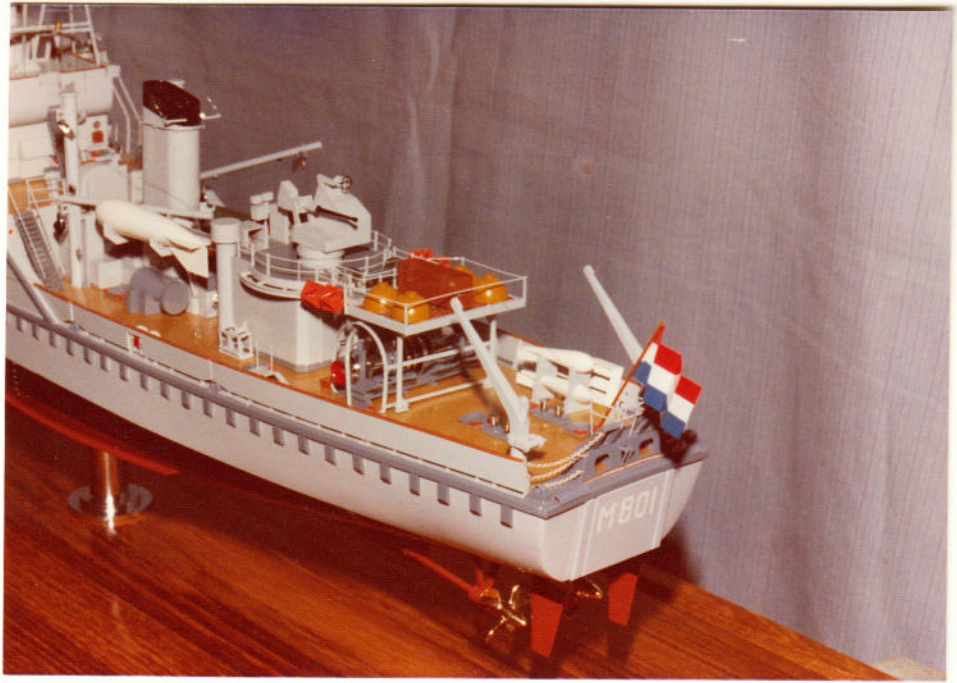

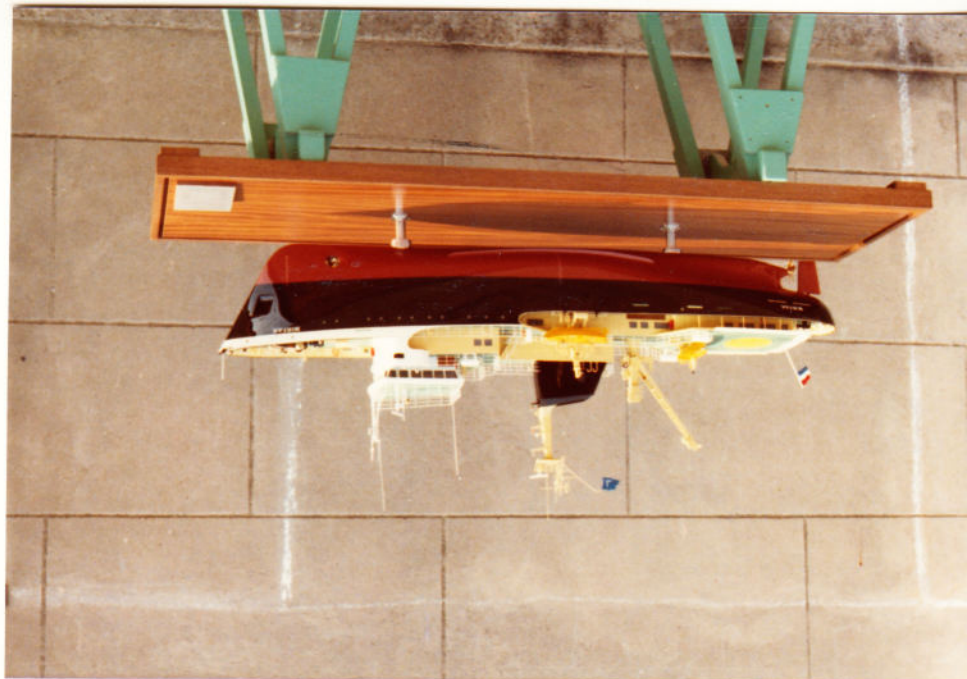
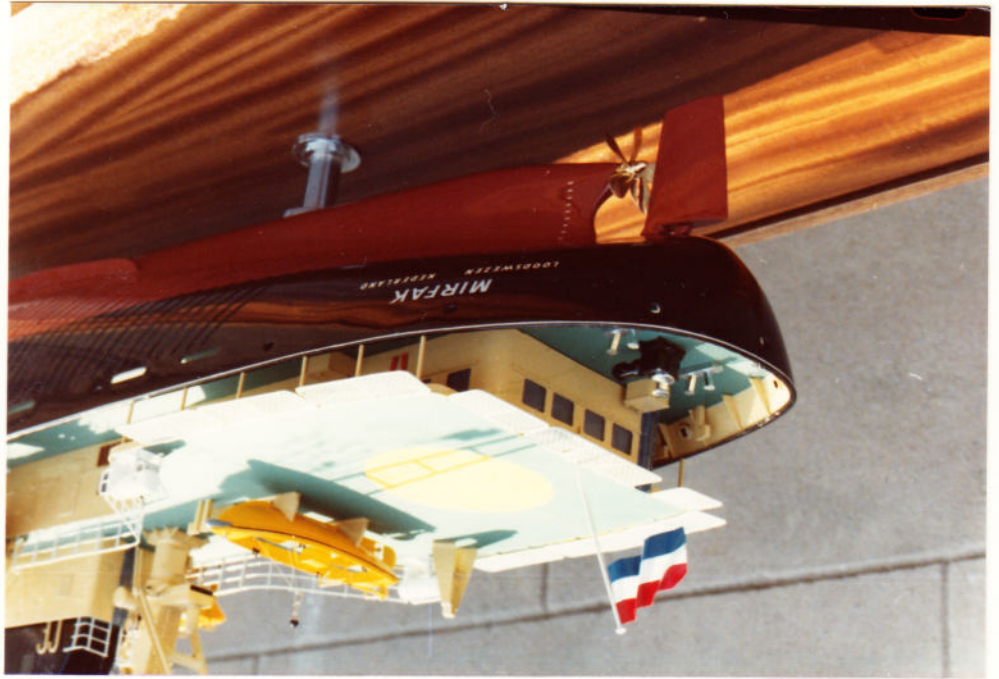
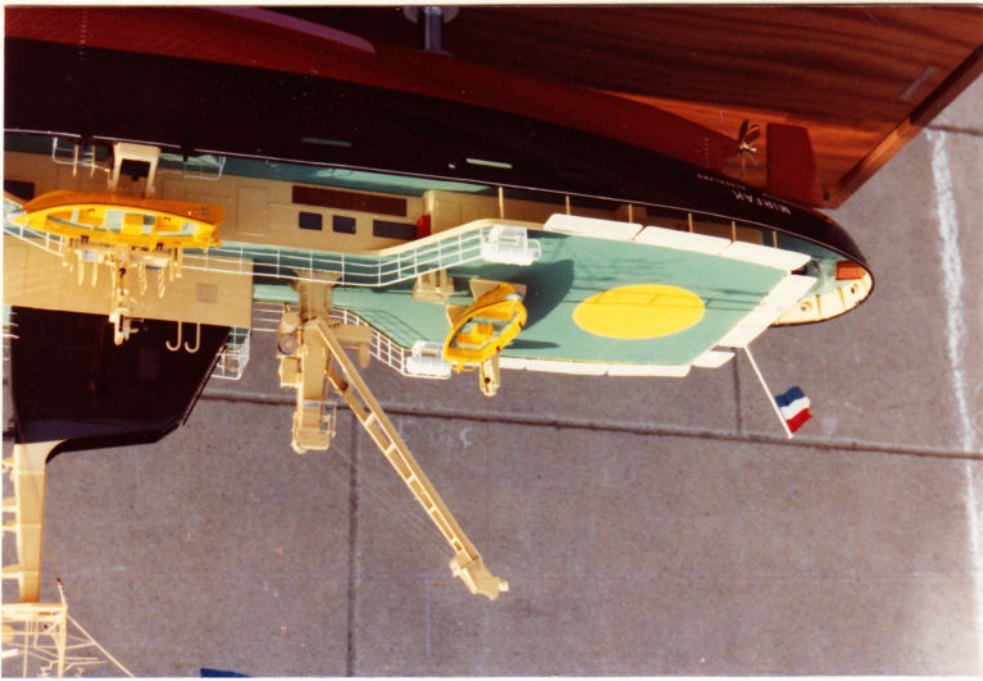

161 mm

21-4-78
 1:50
 VOYR & ZH.
 LOODSWERK



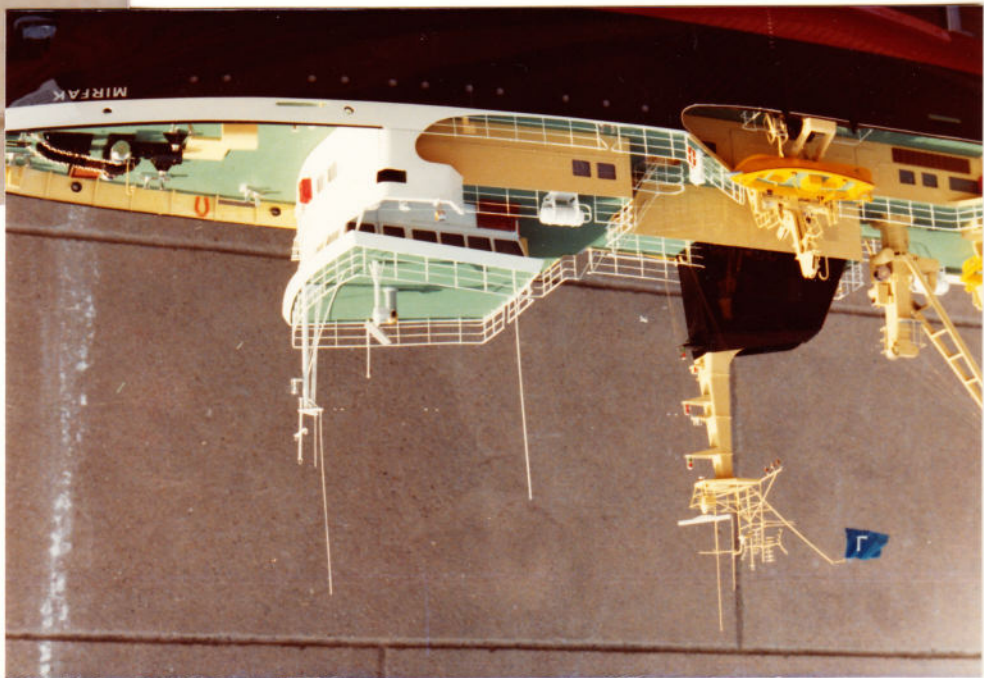
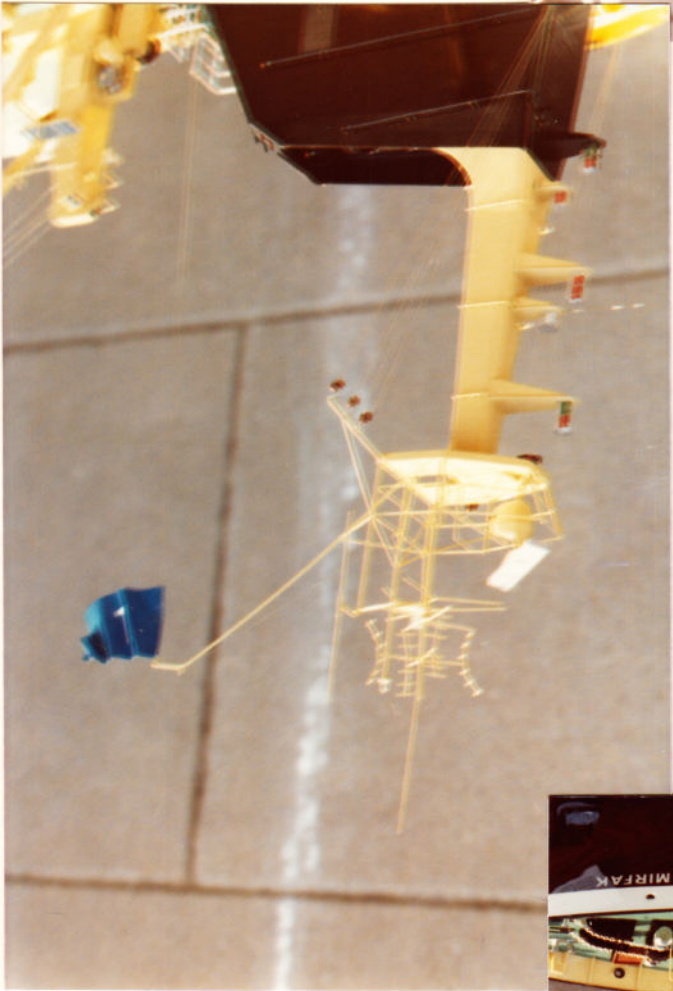
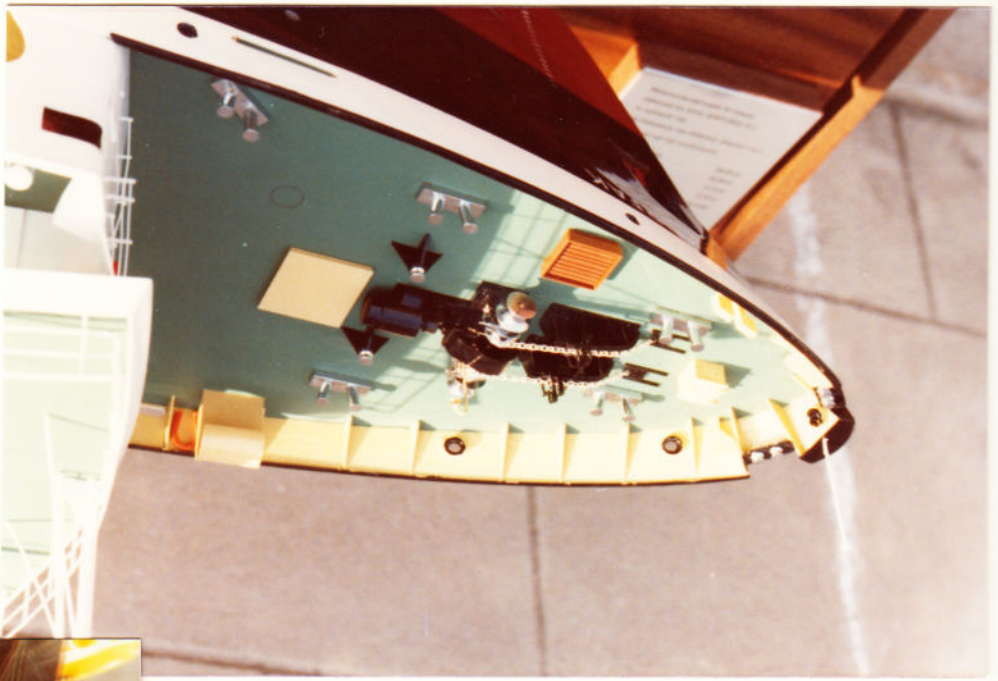



Projekt: MIRFAK
Baujahr: 1988
Bauort: ...
Länge: ...
Breite: ...
Tonnage: ...
...
...
...
...
...
...
...

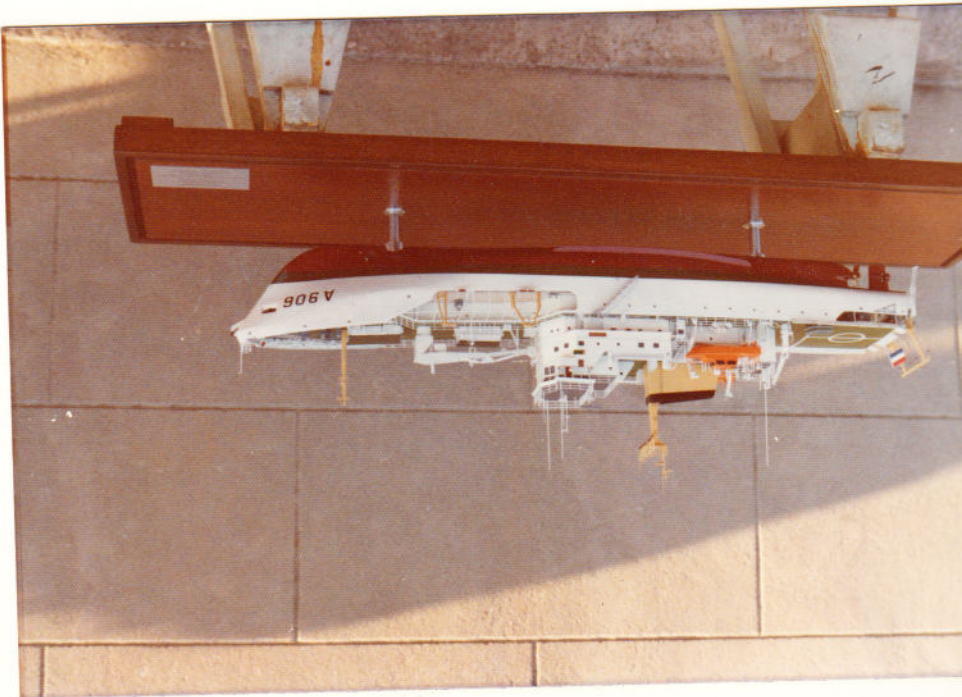
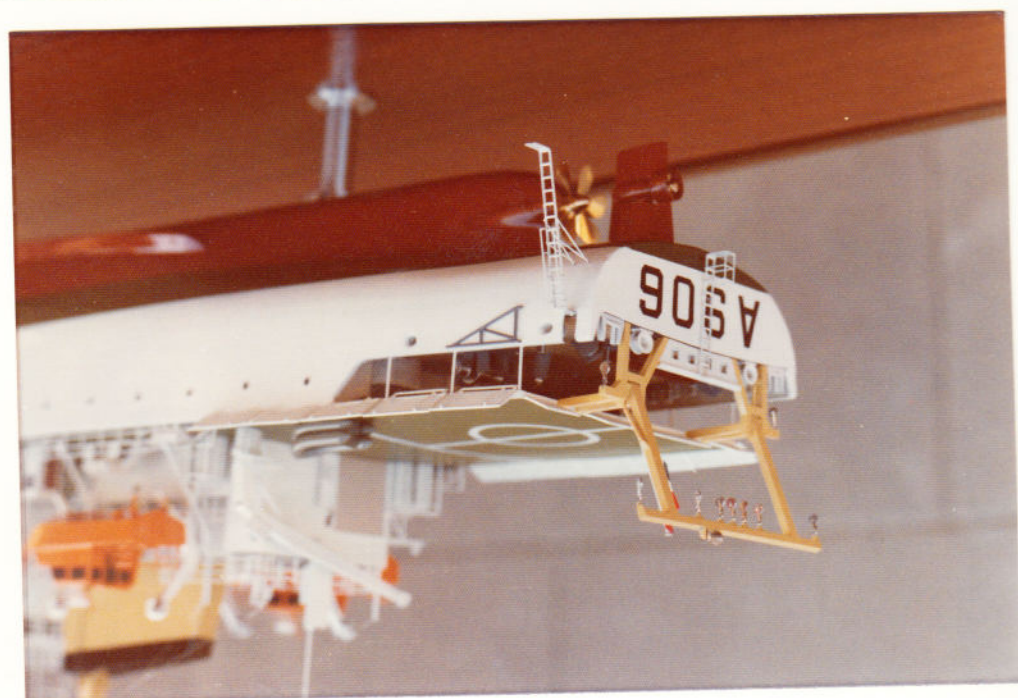
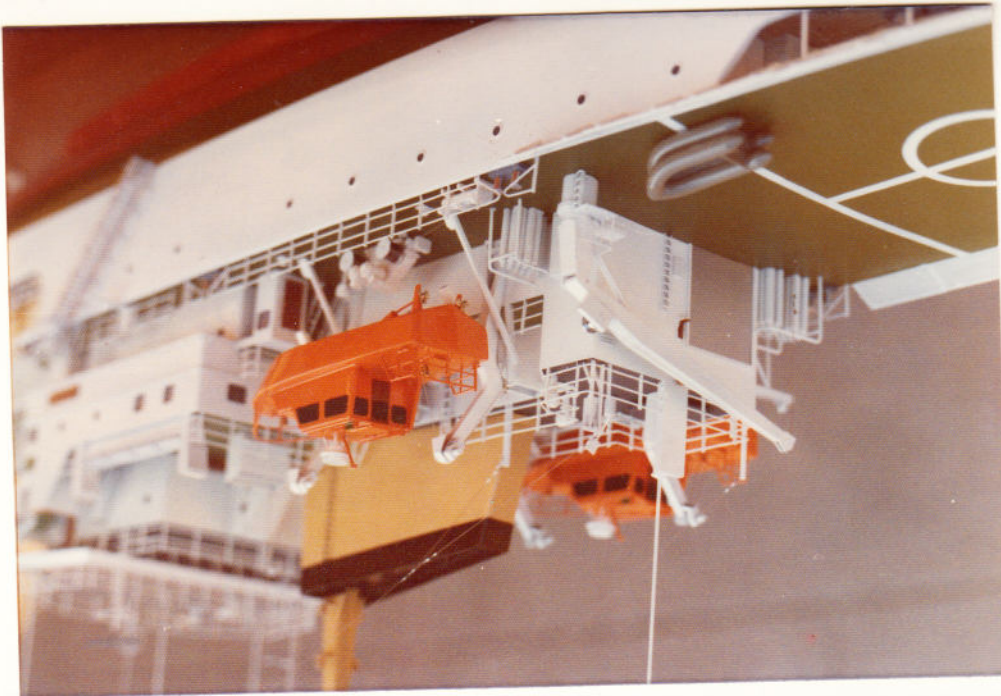

OCEANOGRAPHISCH BN. 618
 OPNEMINGSVAARUITJG
 TYDEMAN
 2x
 1:100
 17-12-77
 MERUDE
~~Merude~~
 1ste etage
 970 mm



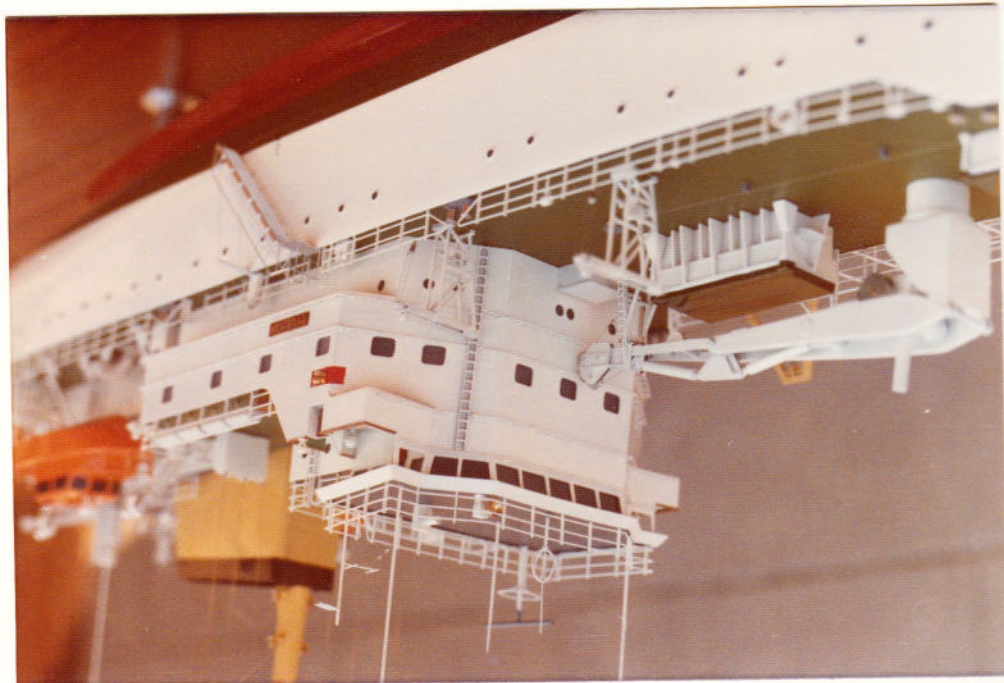
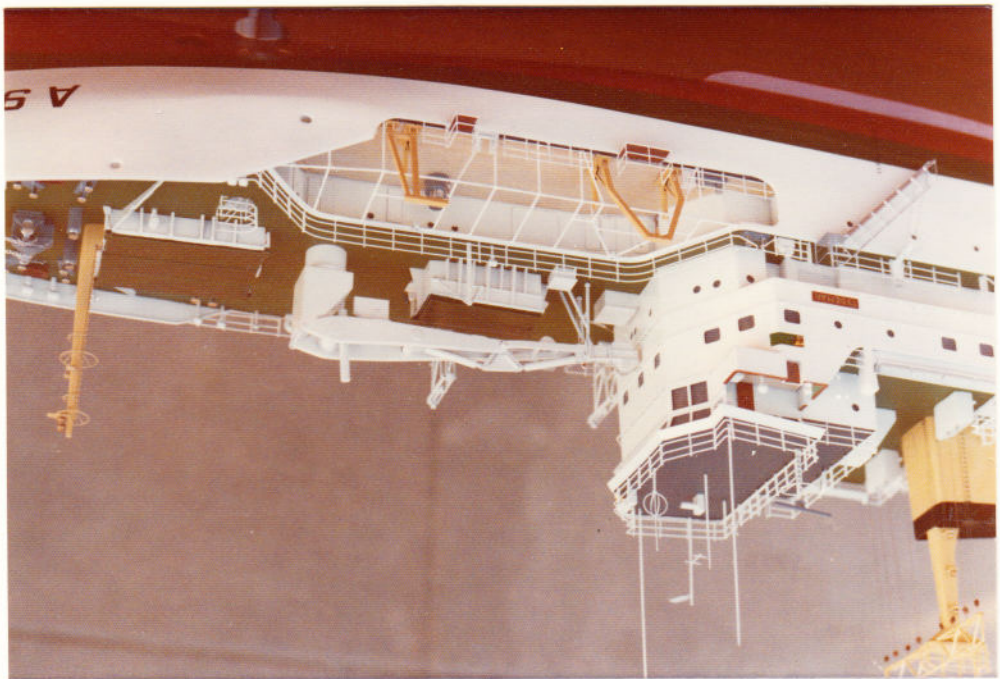
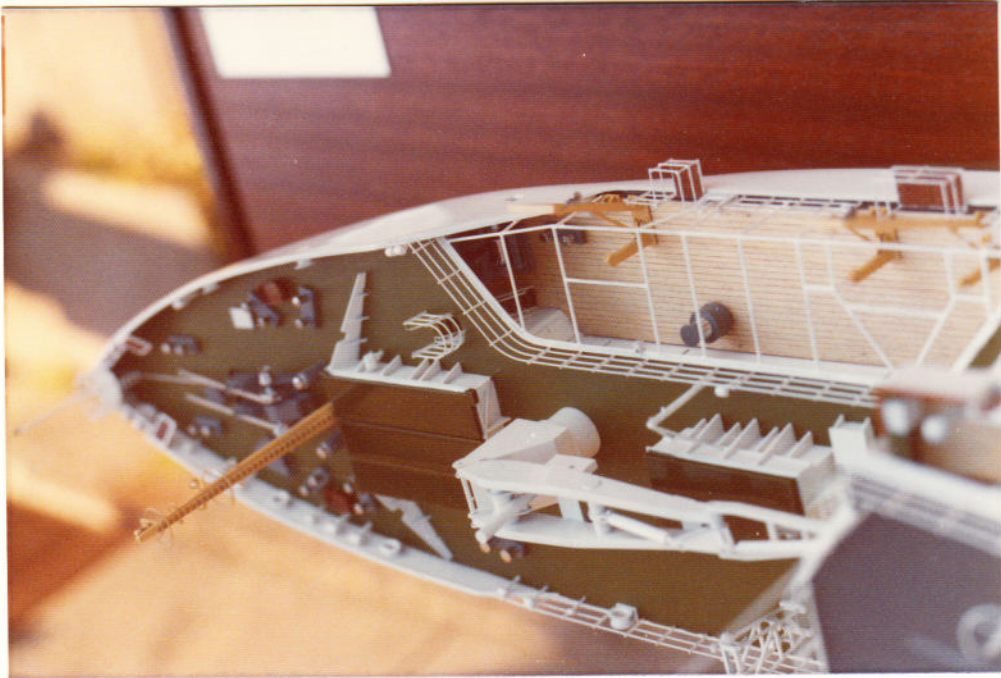



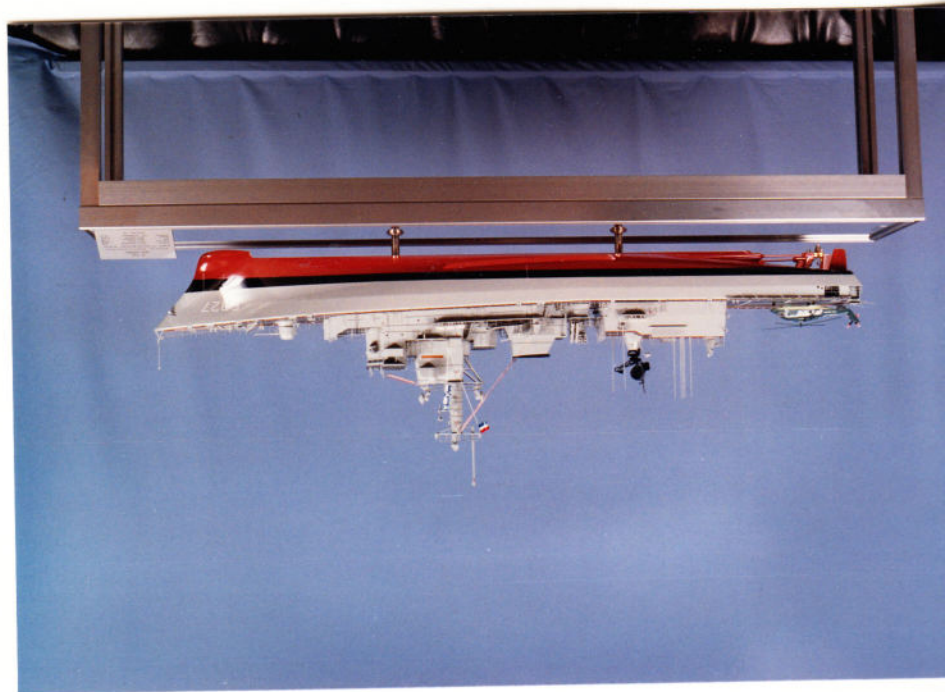
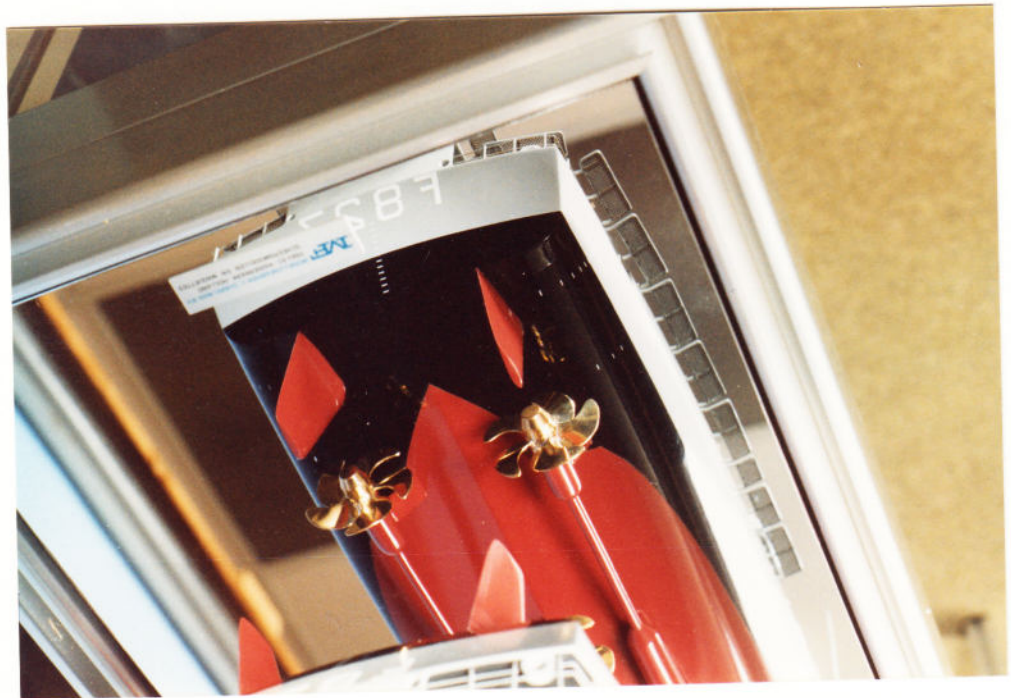

M. Fregat "Karel Doorman"
 Kon. Marine -
 2x 1:100
 (incl. tafel o-kiel).
 1e 18-4-88
 2e 10-5-88
 totaal. 880 uur.



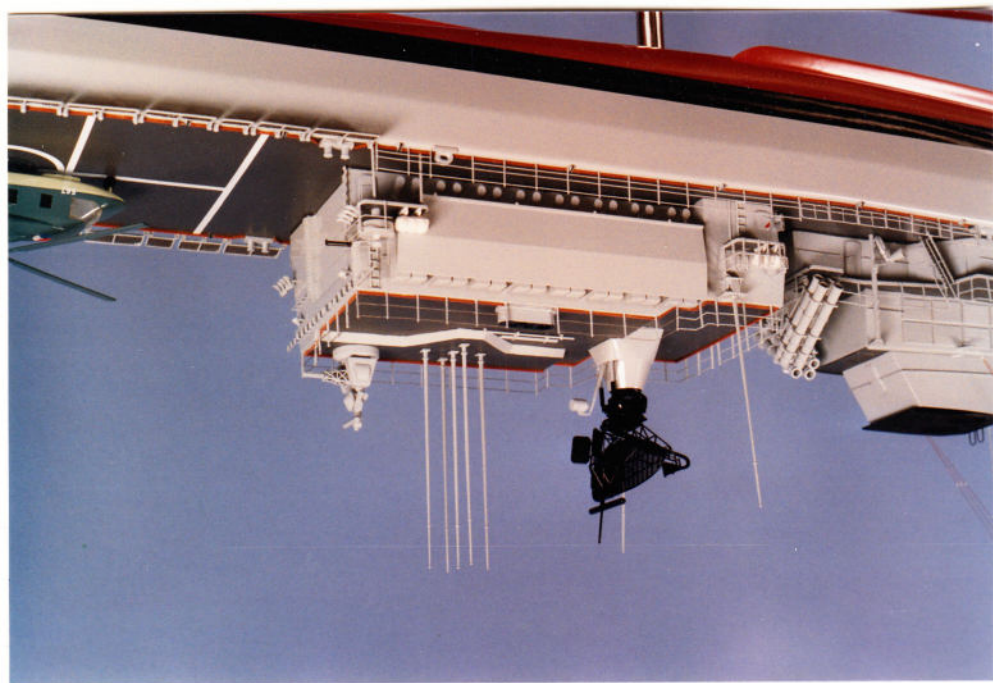
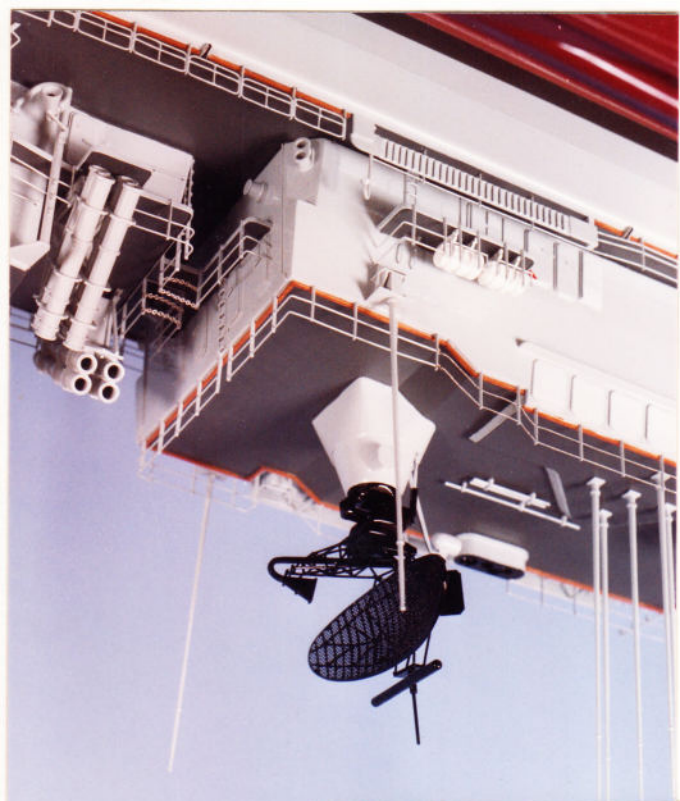

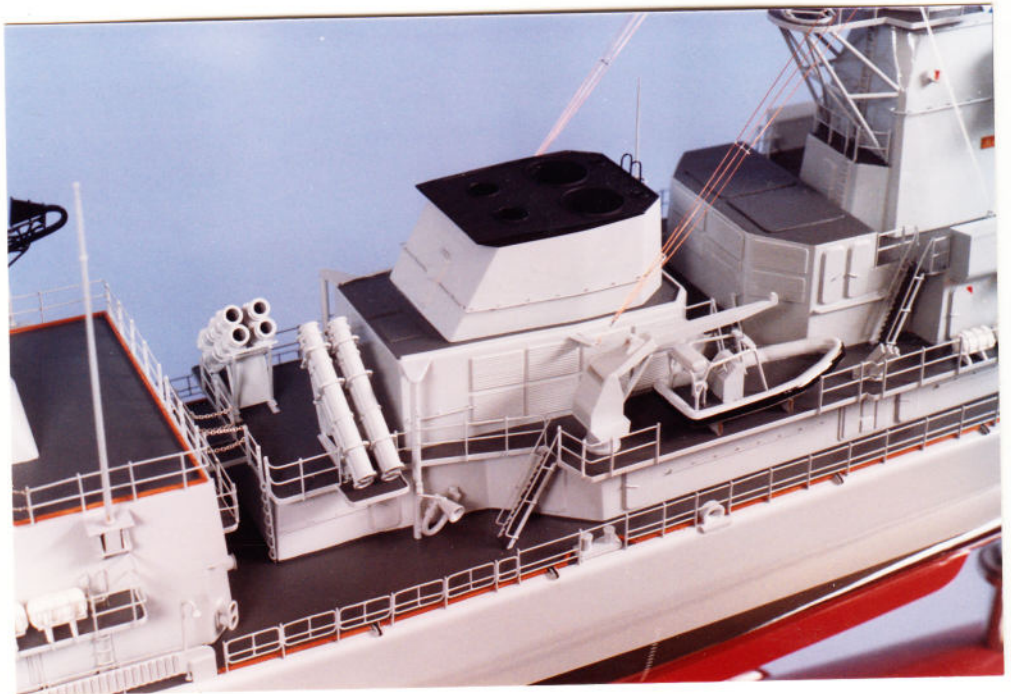
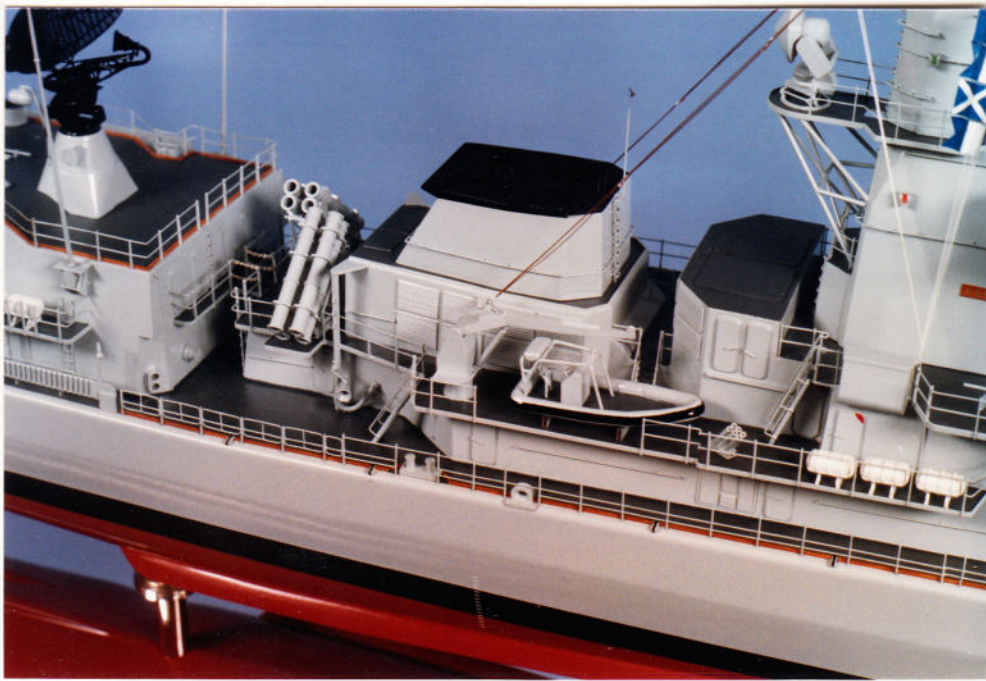

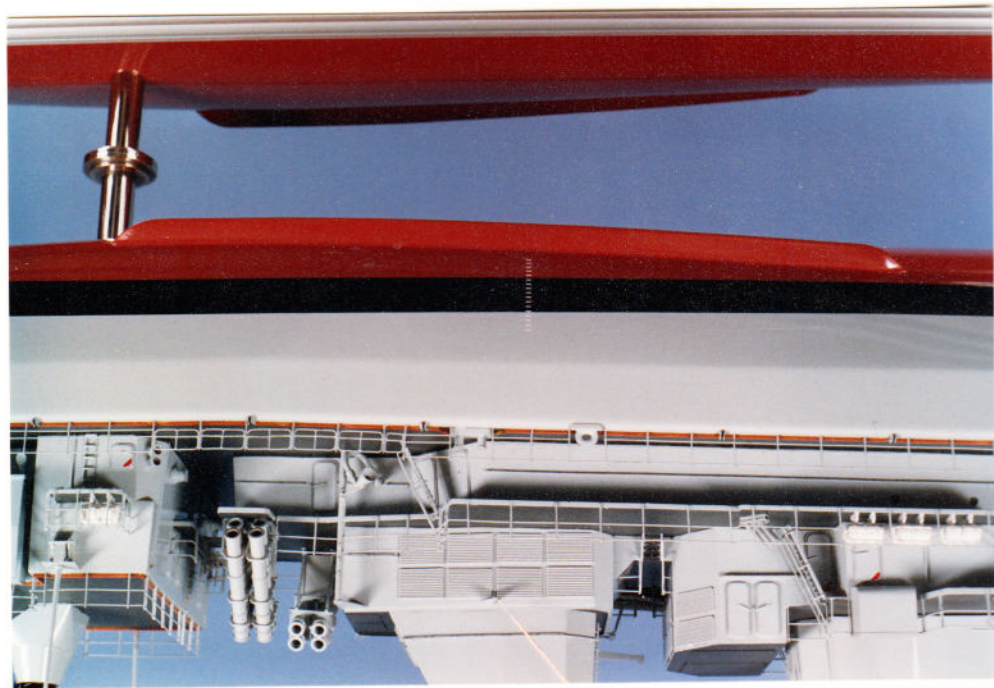
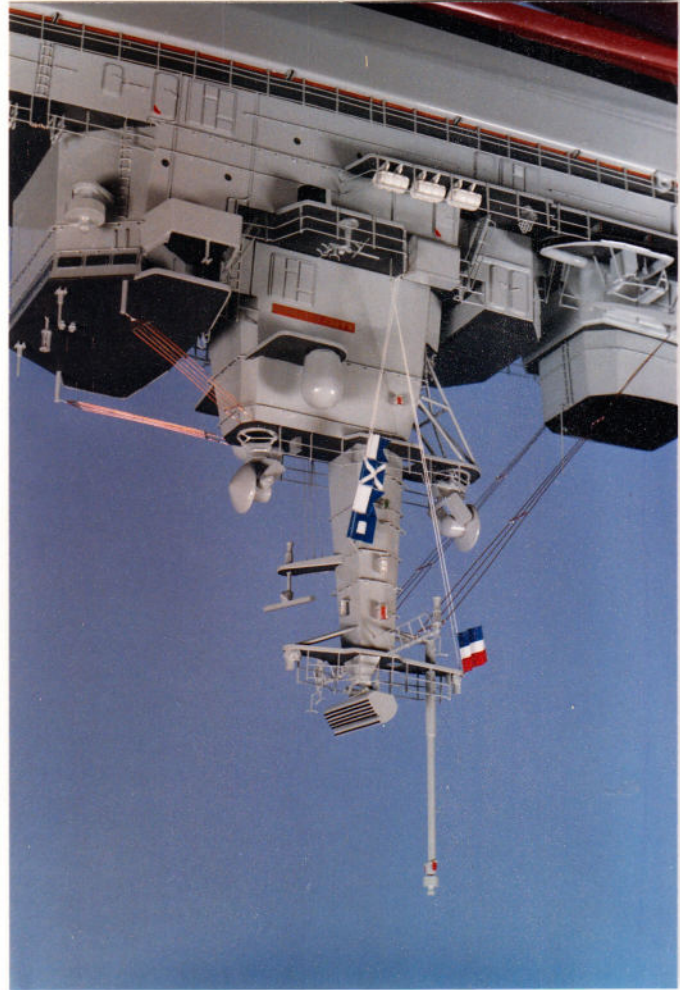
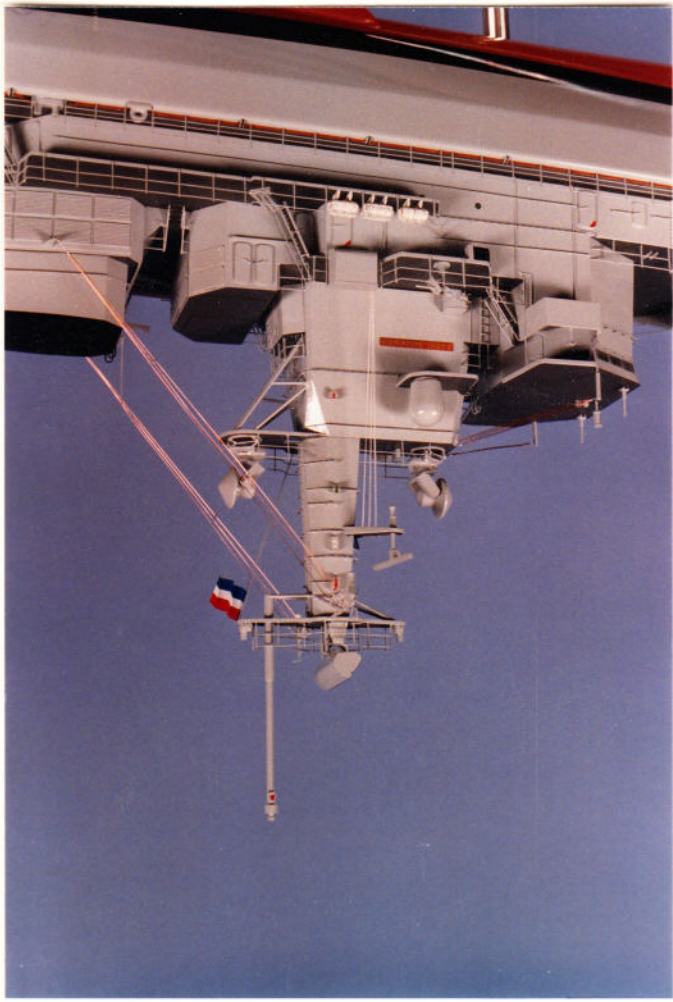



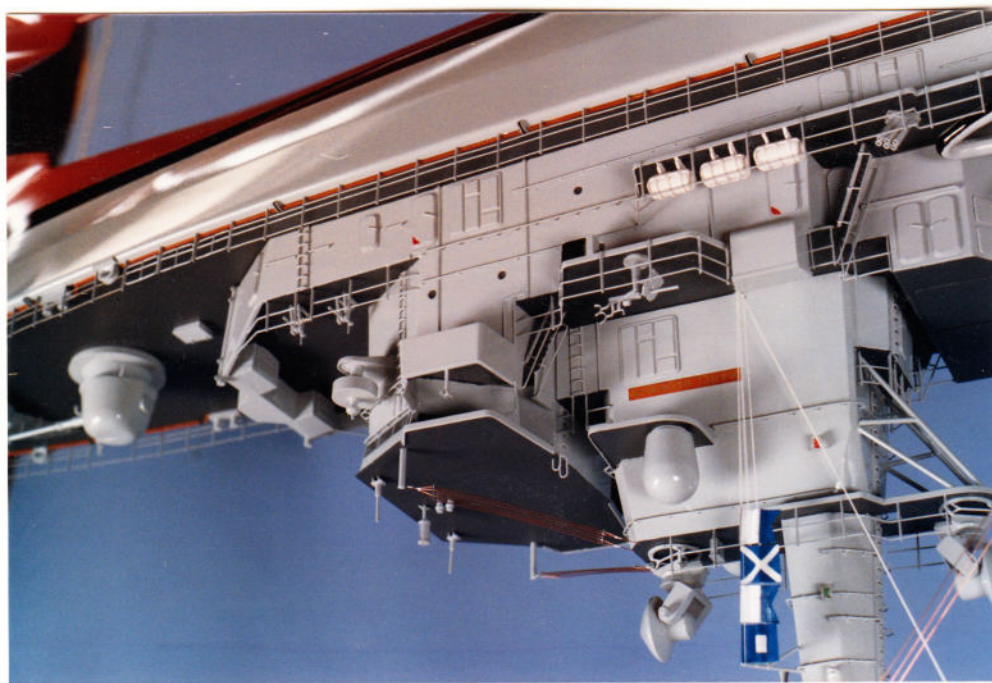
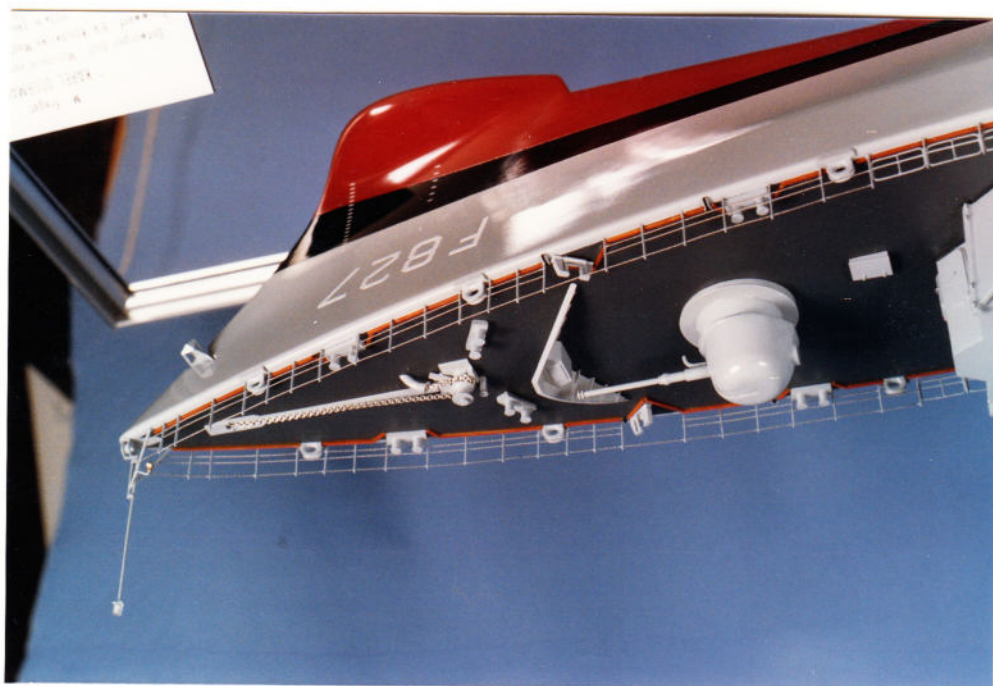
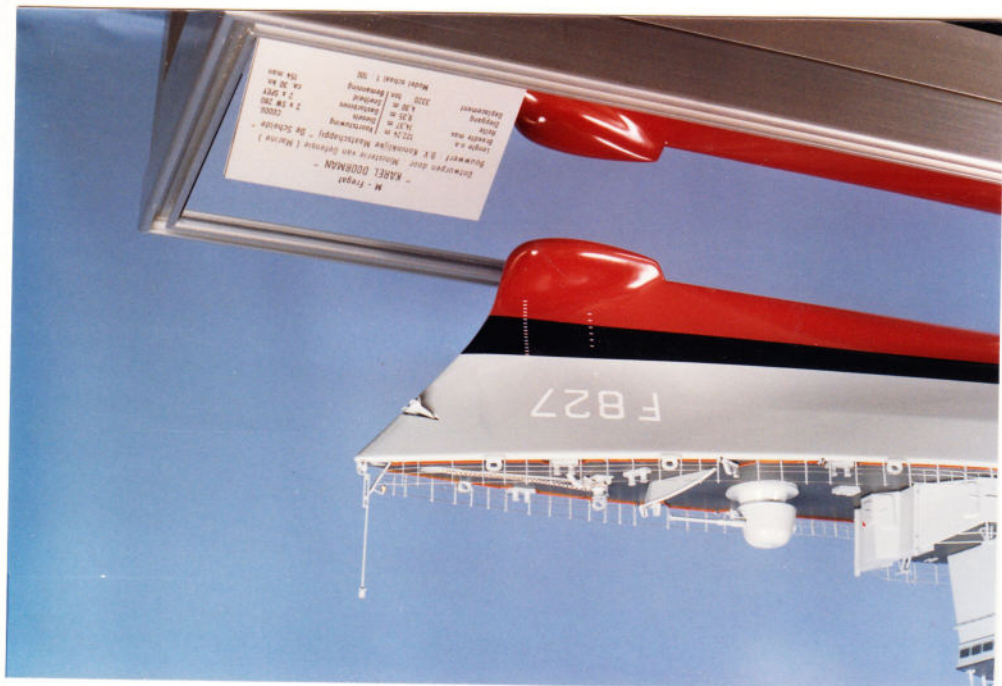

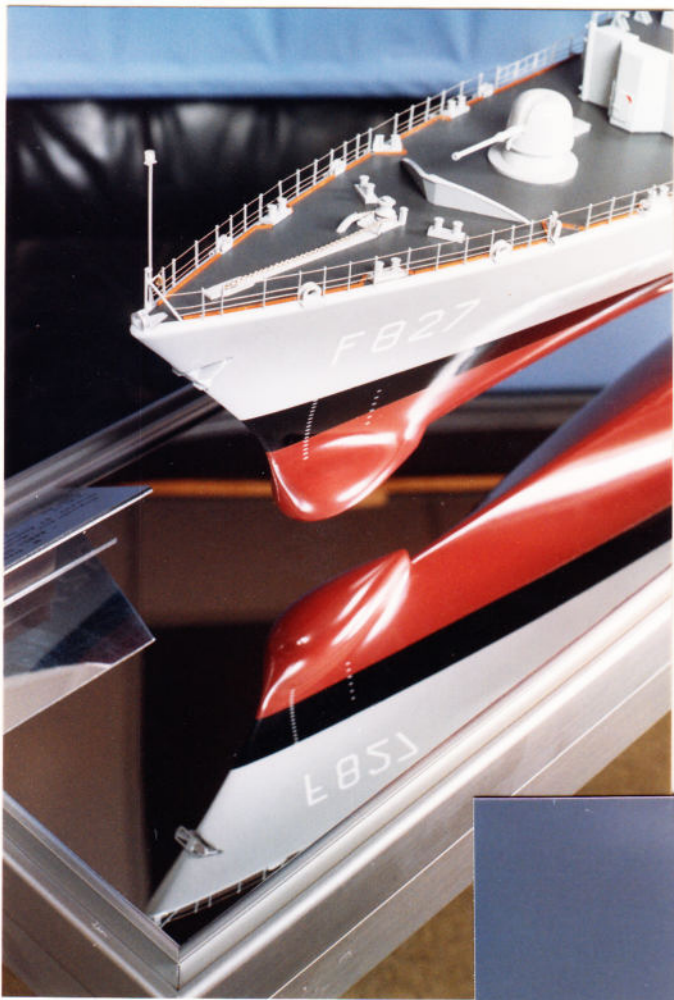

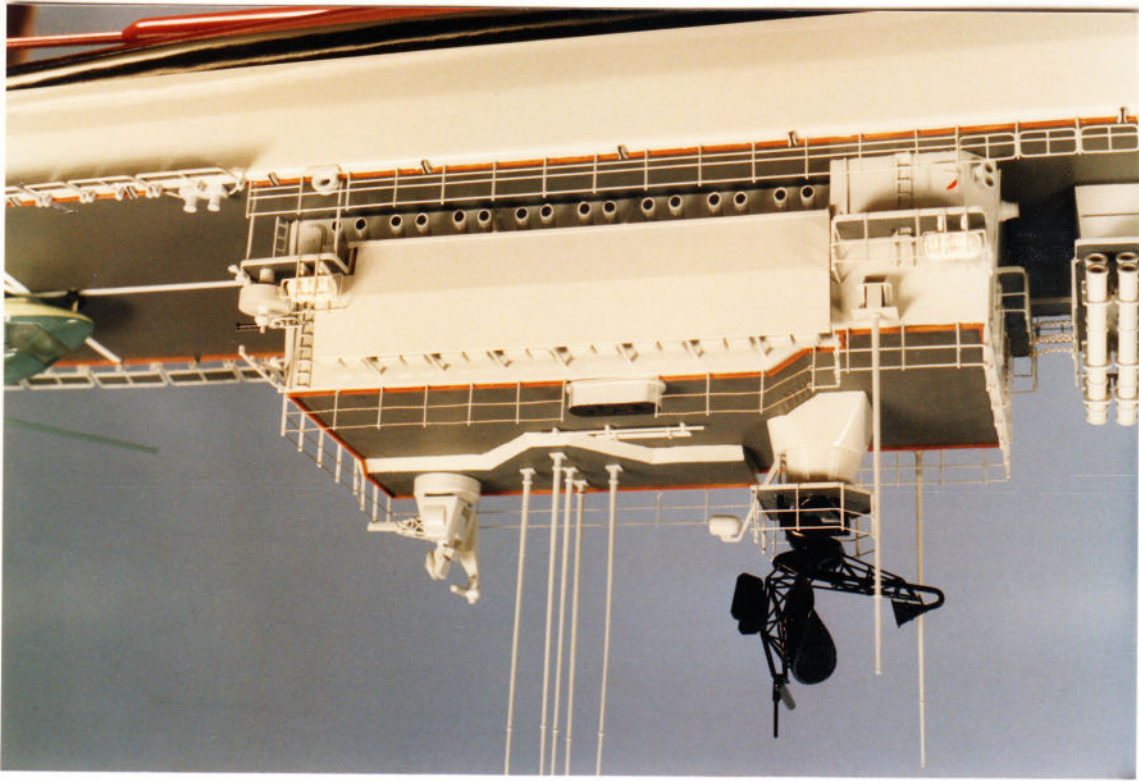

beoordelingen 2e model.
 geel heli copter.
 heldi markering
 bordes onder radar.
 zwarte cilinder
 kippende op dek.
 sceneriewerk by reedingsbureaus



Seopterwork by redding-trommels

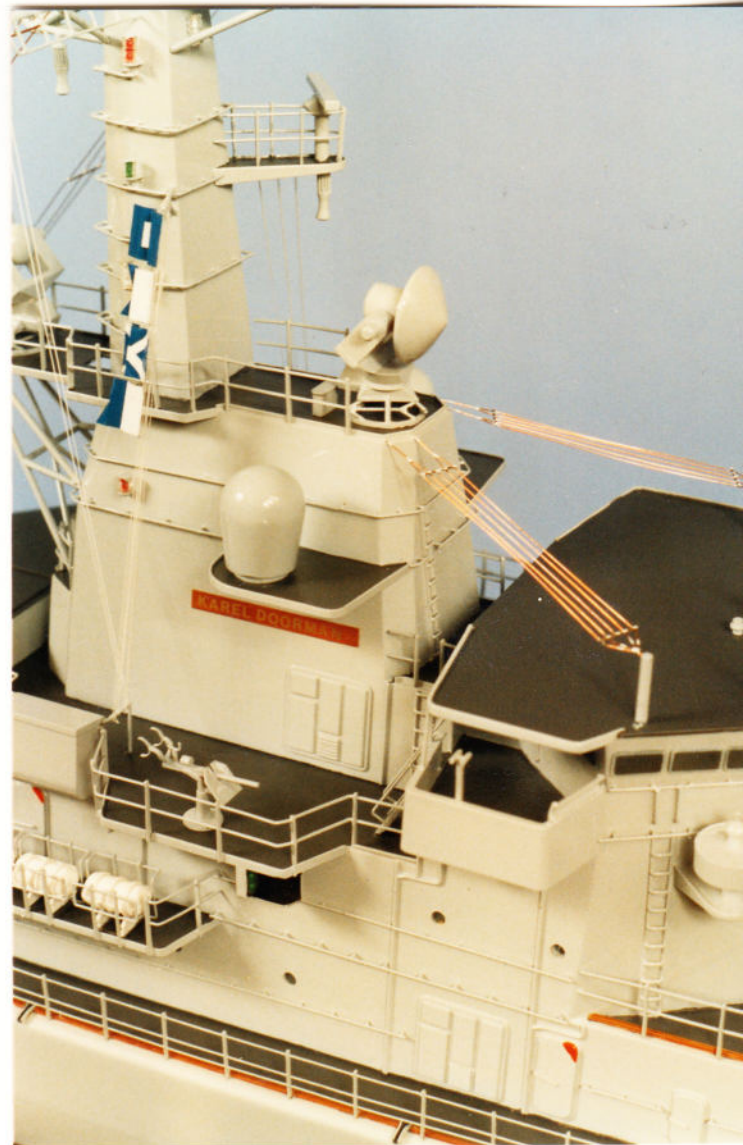

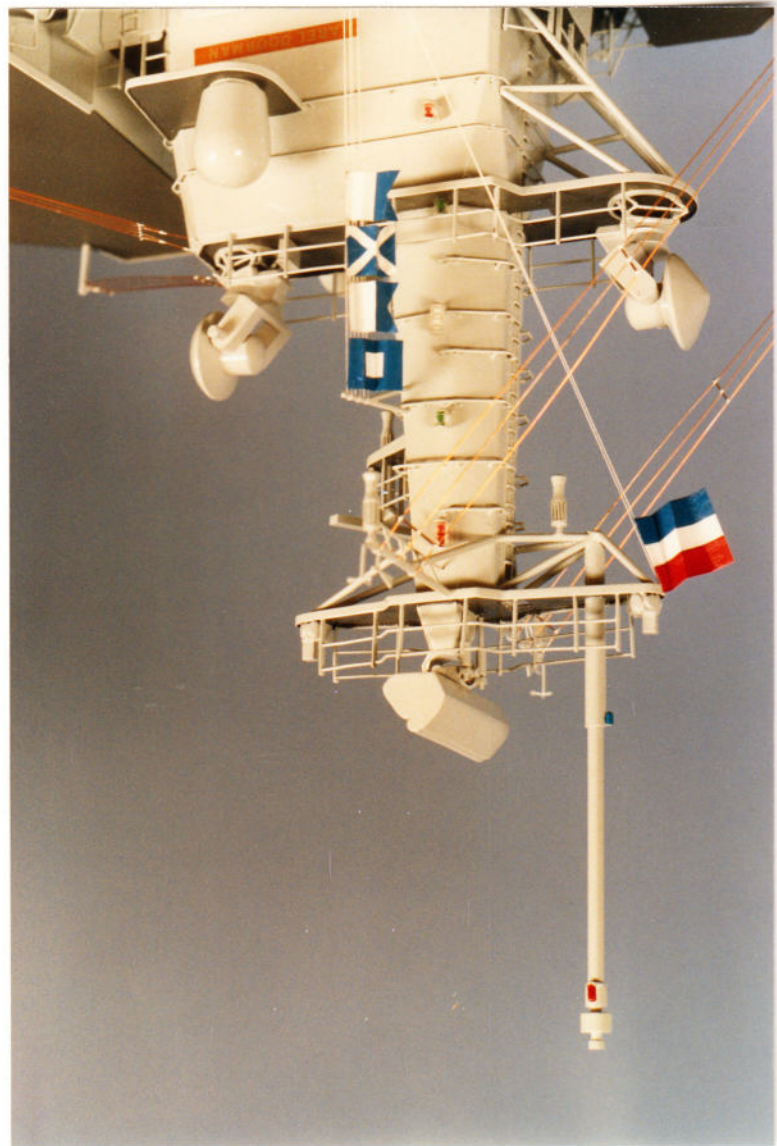

gear streven op top noden.
andere sleep draait.
wijzing, systeem of by sleep.

VAN RIETSCHOTEN & HOUWENS
1:100

BEWEEGBARE MODEL
VOOR WERKING STABILISER

10/8/90

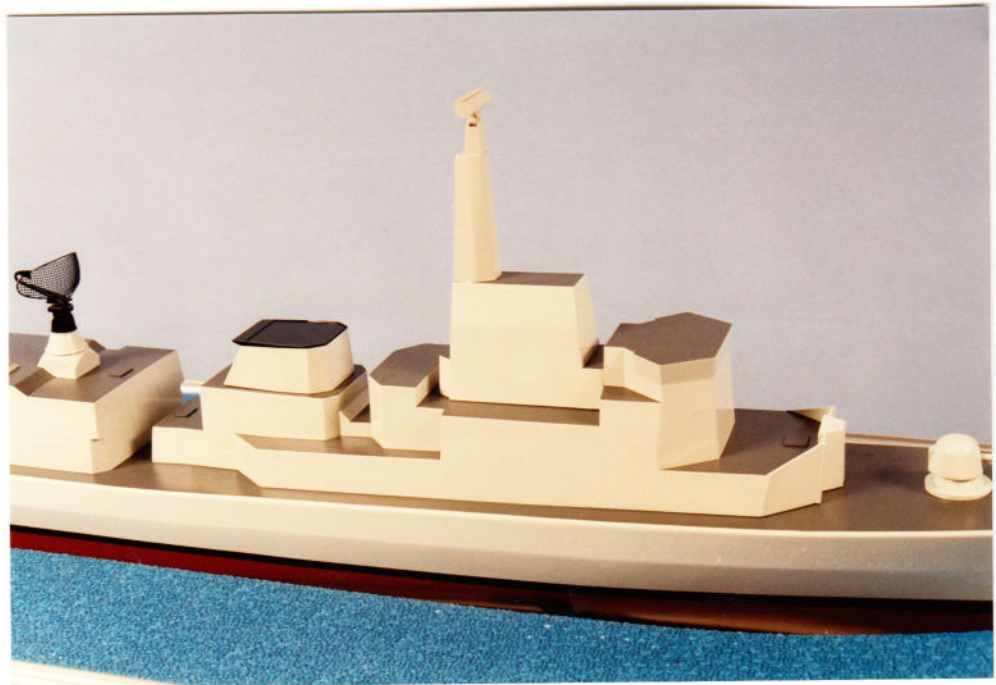
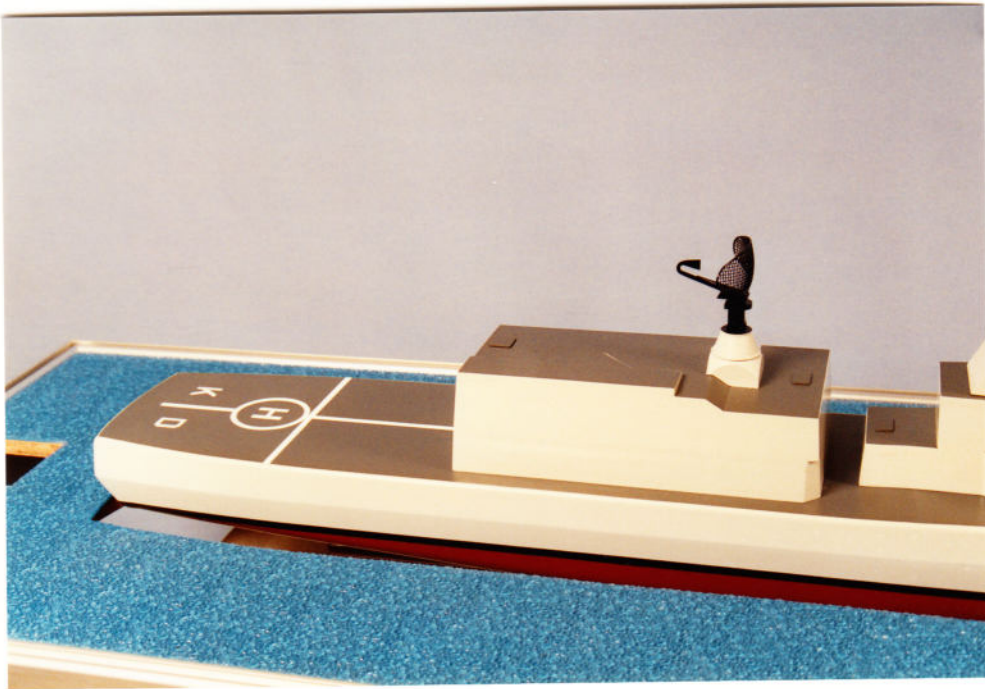
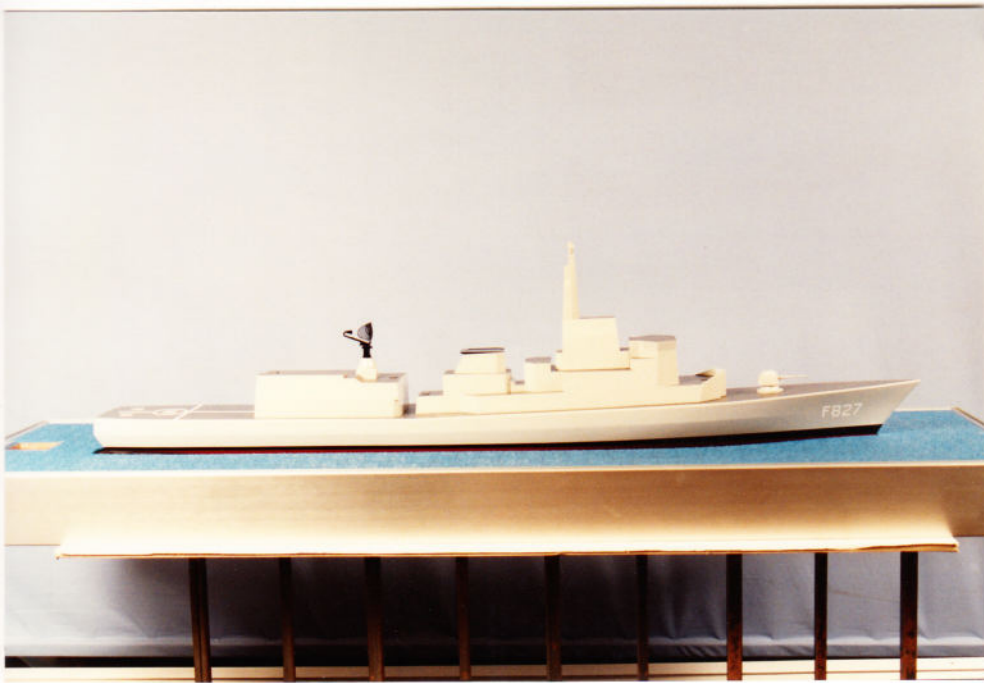

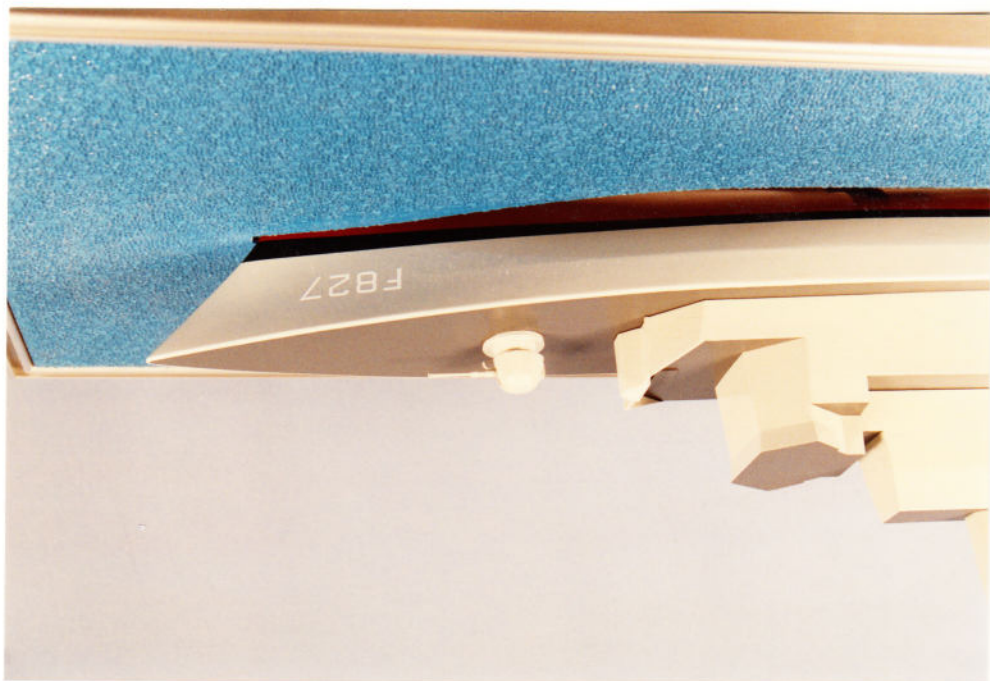



SCHELDE 2
+ HSA 1

LCF

1:100

1^o off. schelde 6/2

2^o " " 4/2

3^o " H.S.A. 13/6

tot. 771 mm.

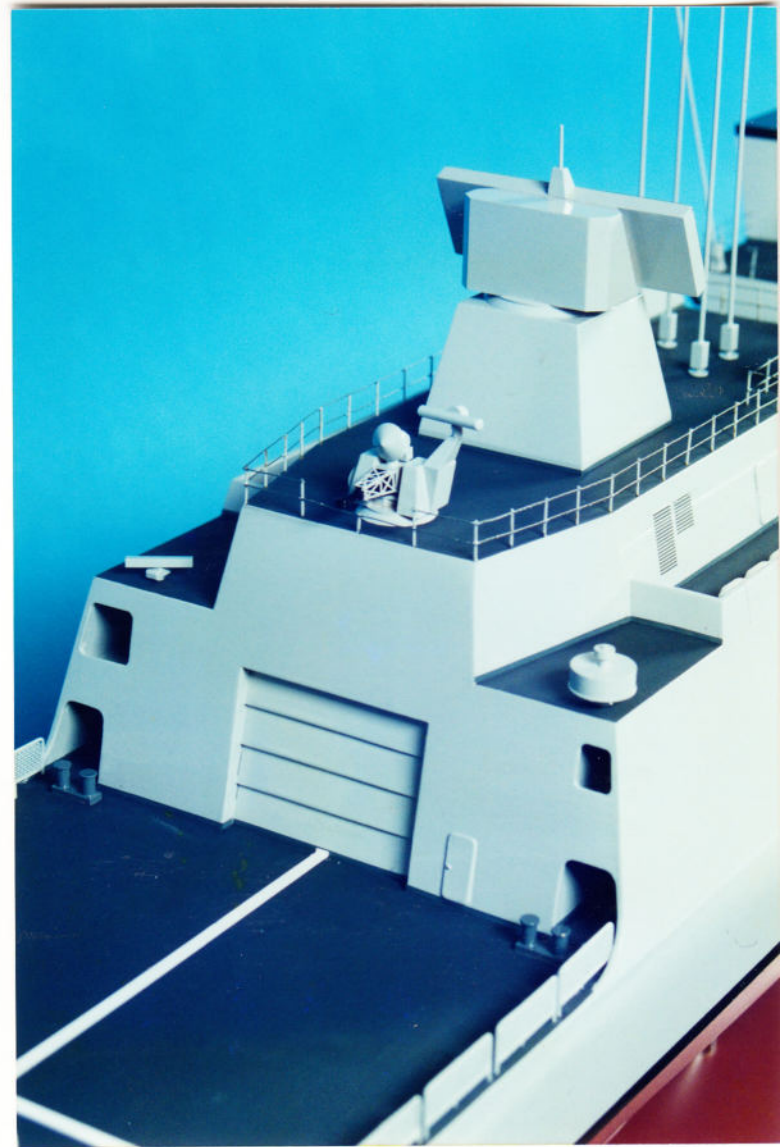

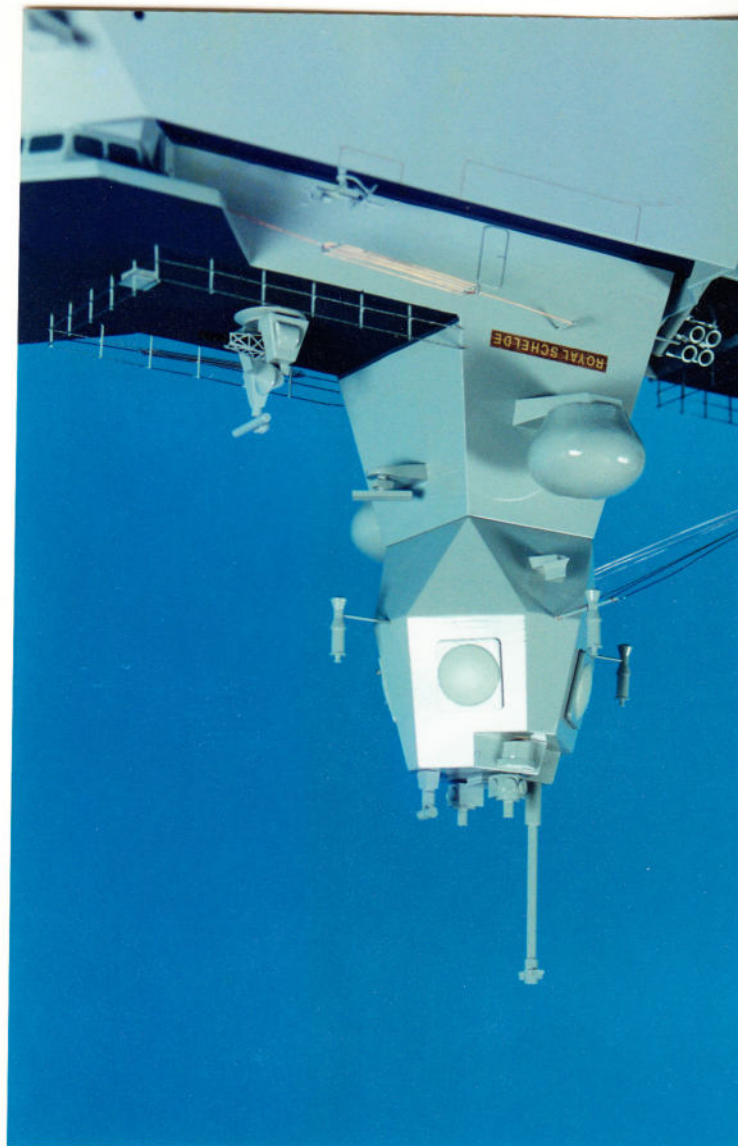
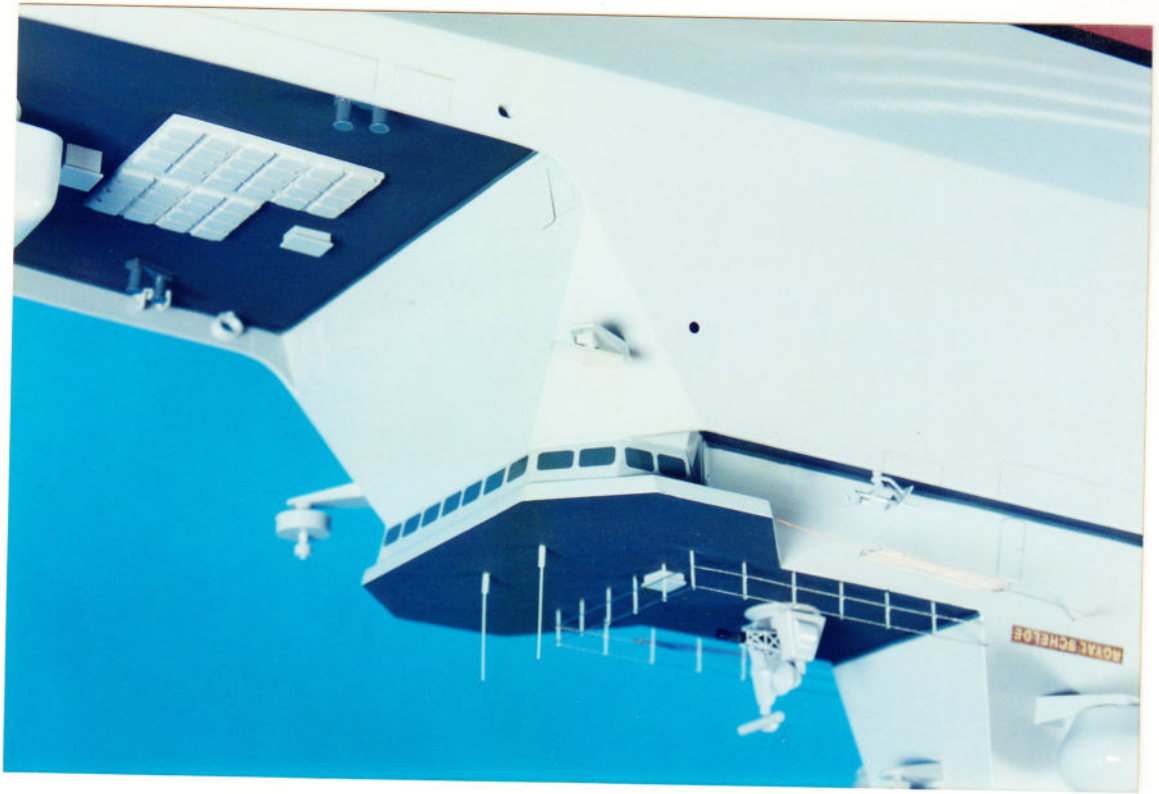

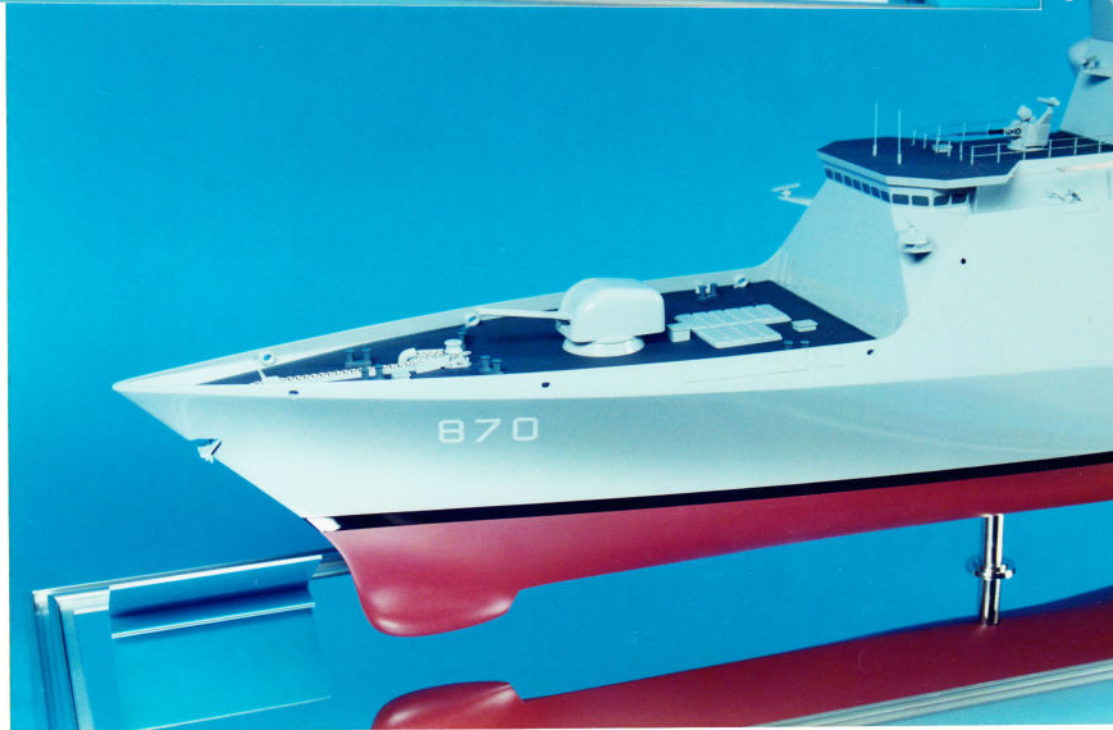

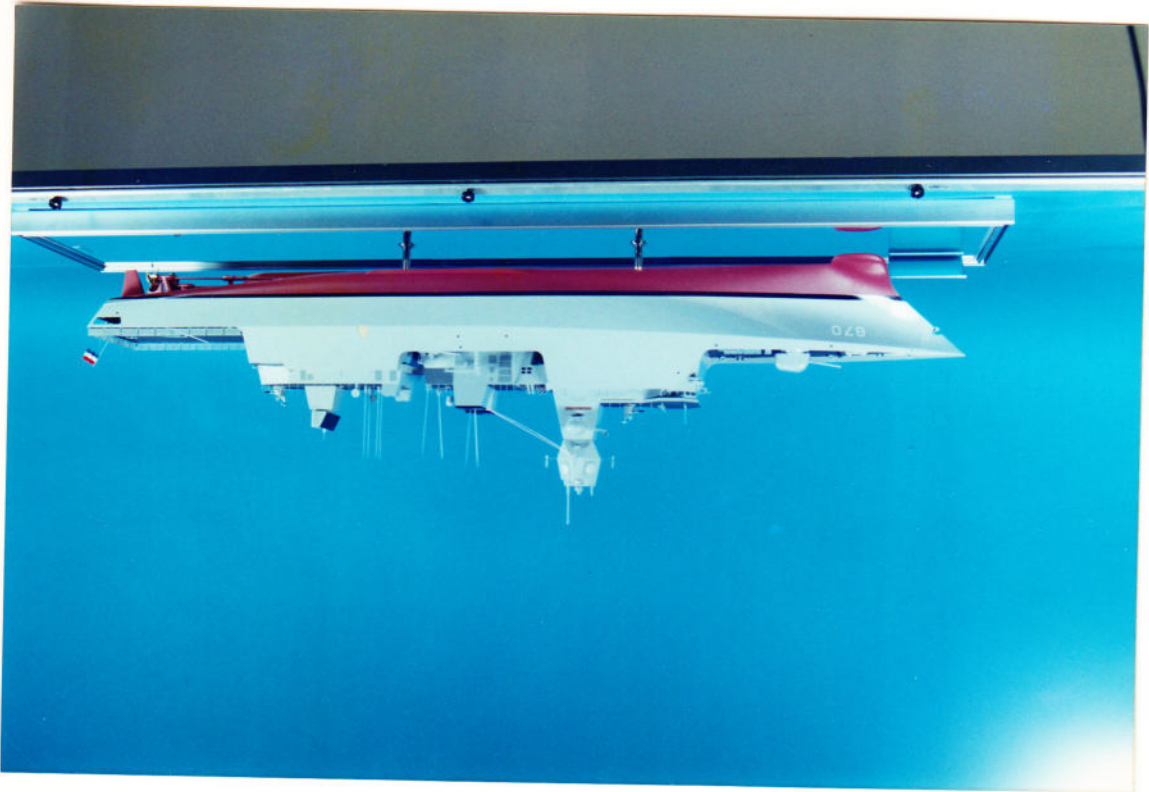

SCHULDE on H.S.N.

11/6/96

13/6/96

4
draaiend
radar.

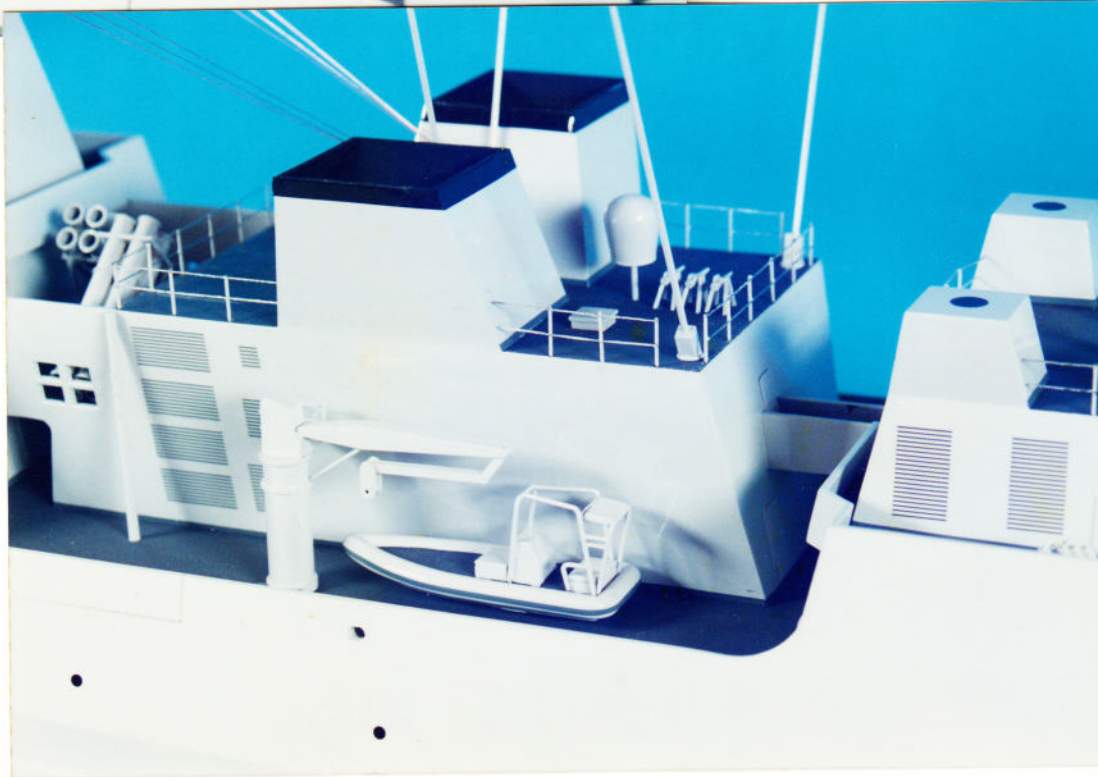
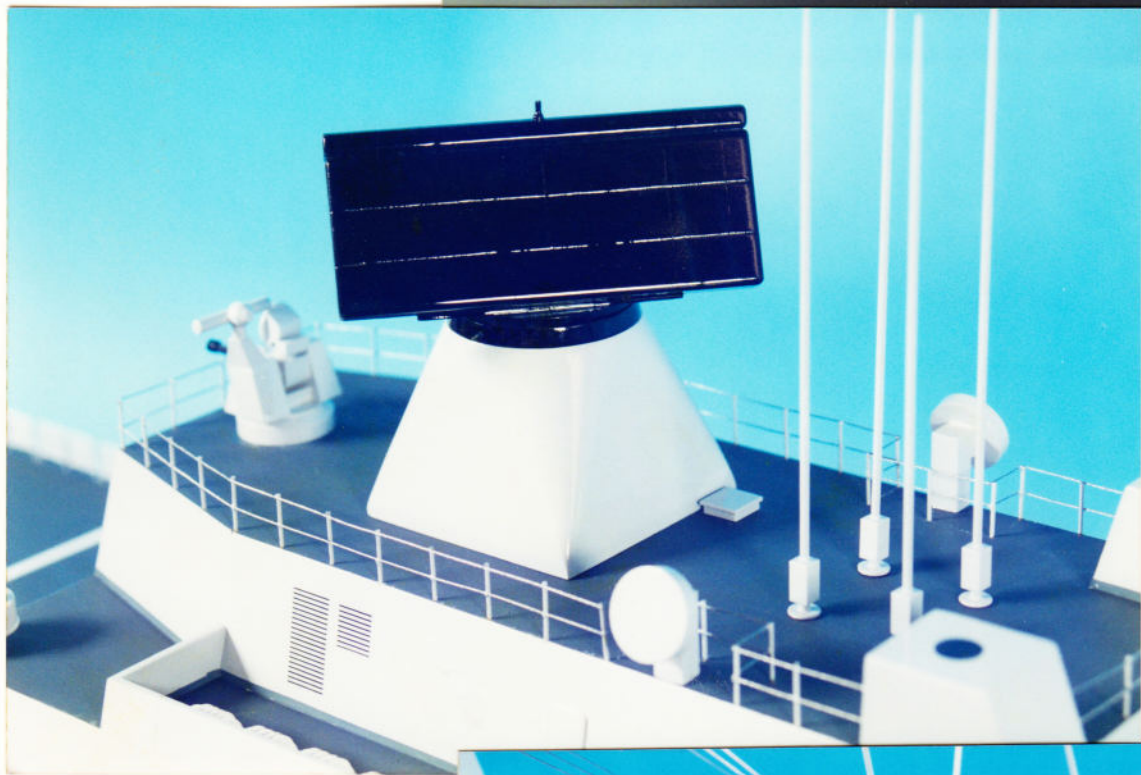

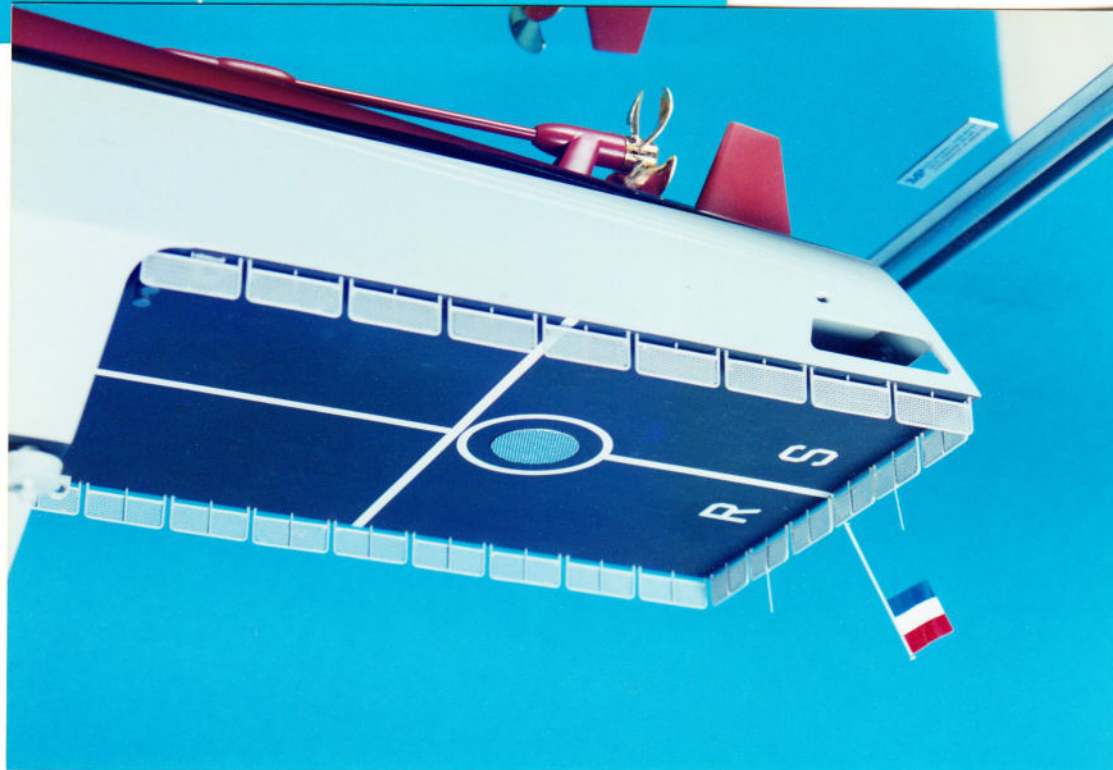
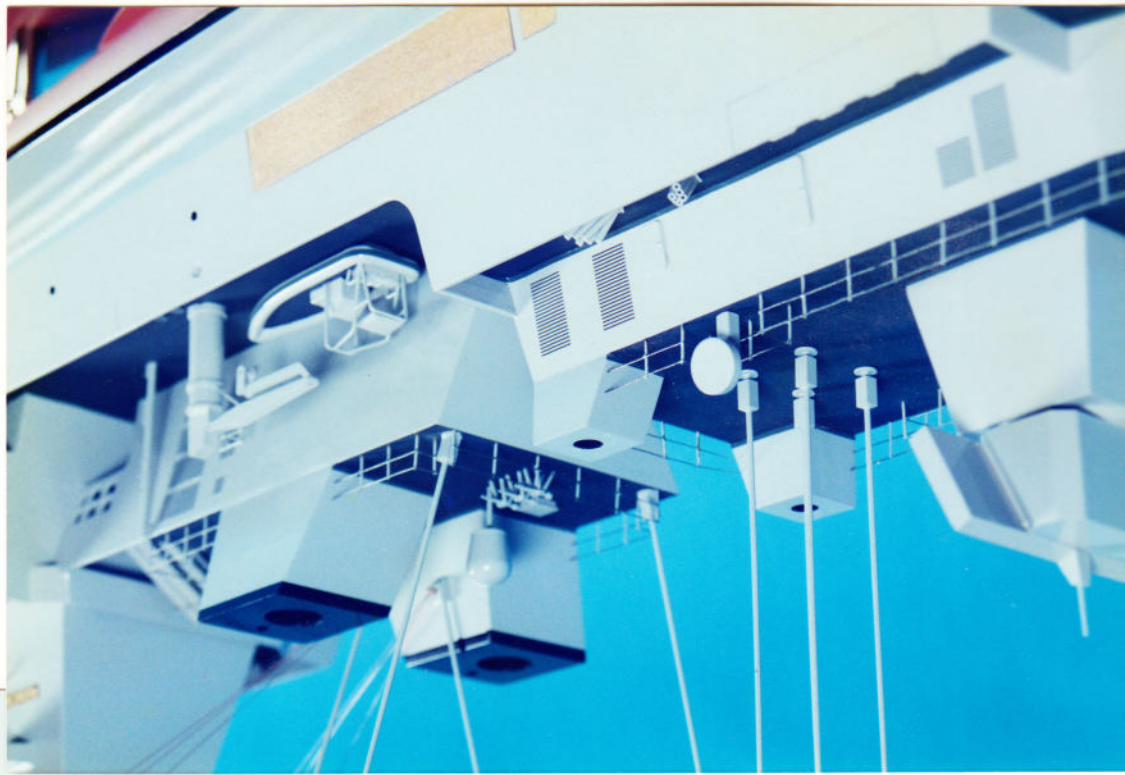

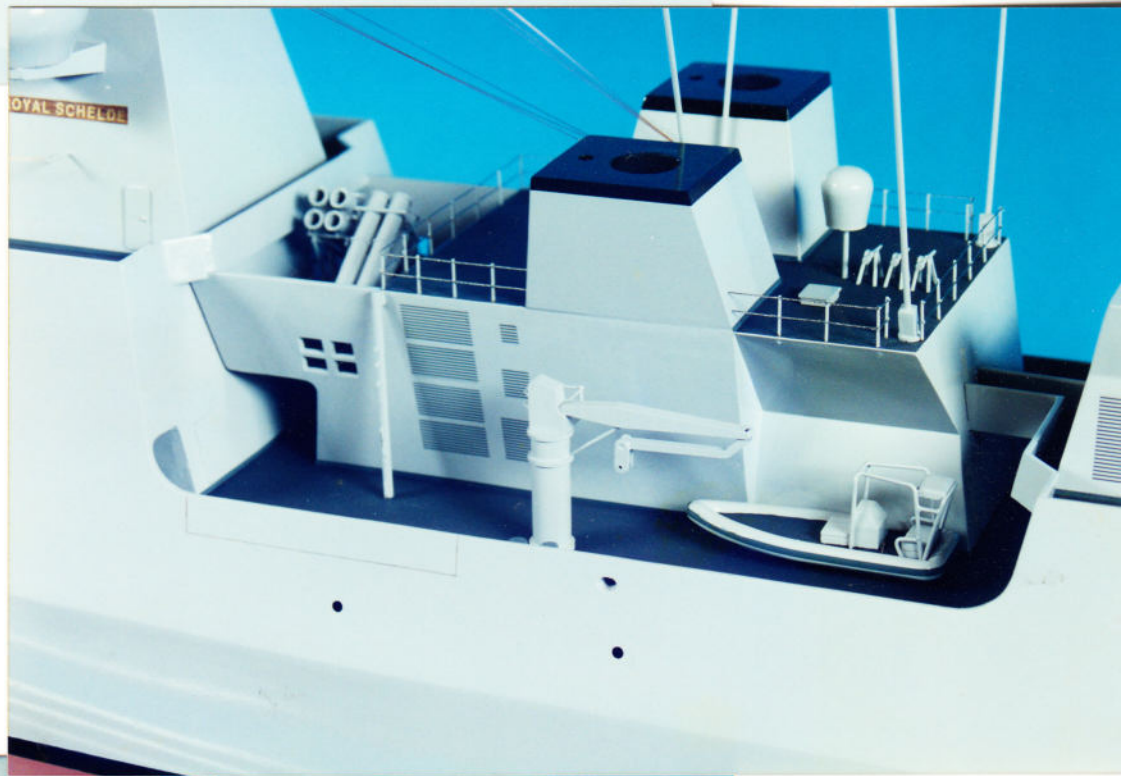
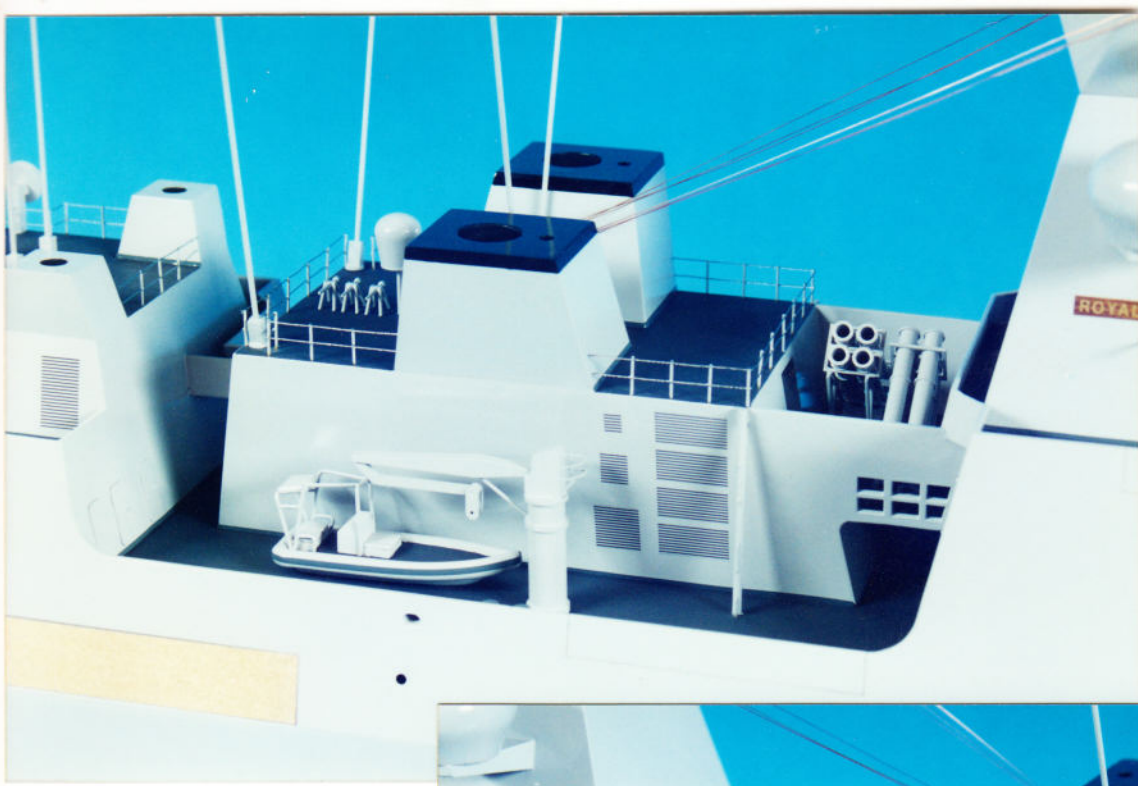





gewyzigde kop 1-1-2001
voor H.S.A.

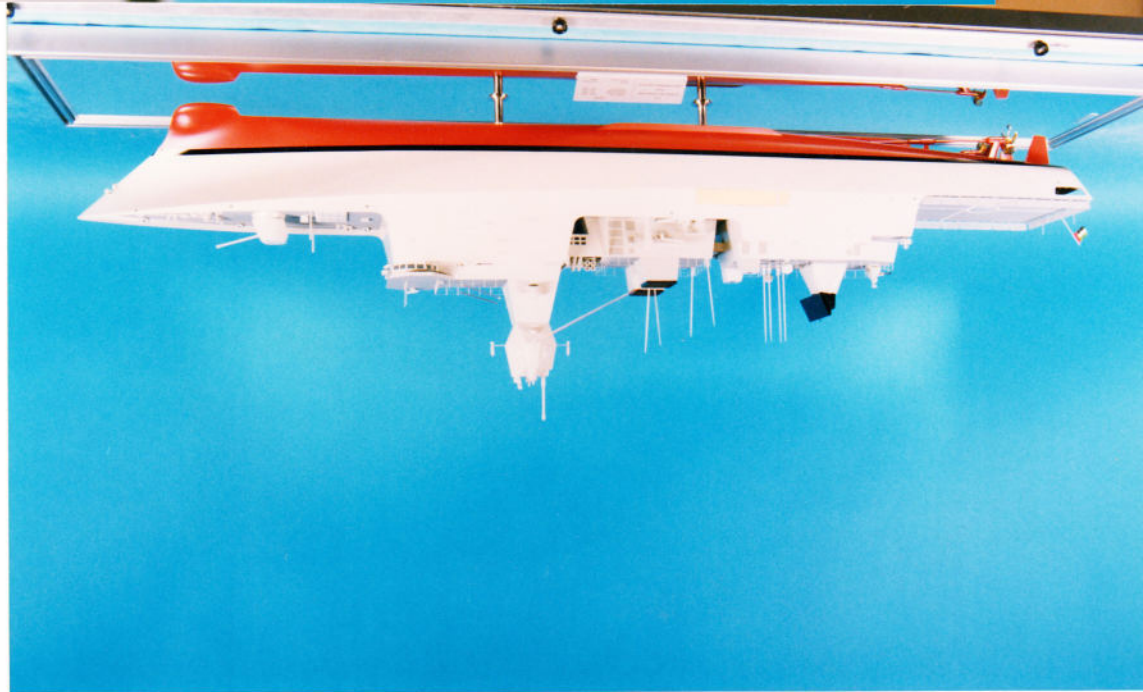
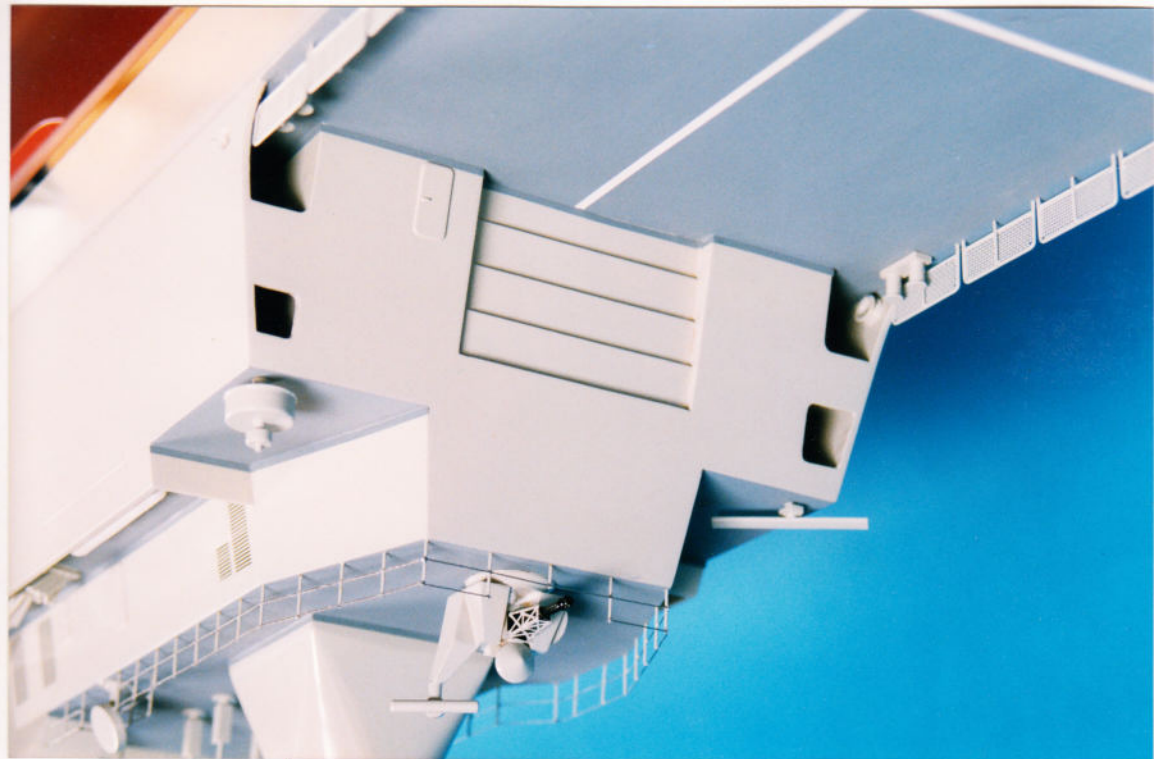

DE SCHEDE
 8 Jun 1996
 L.C.F. fraggot
 1:100
 Door U.A.E.
 (andere kleuren)
 205 mm.

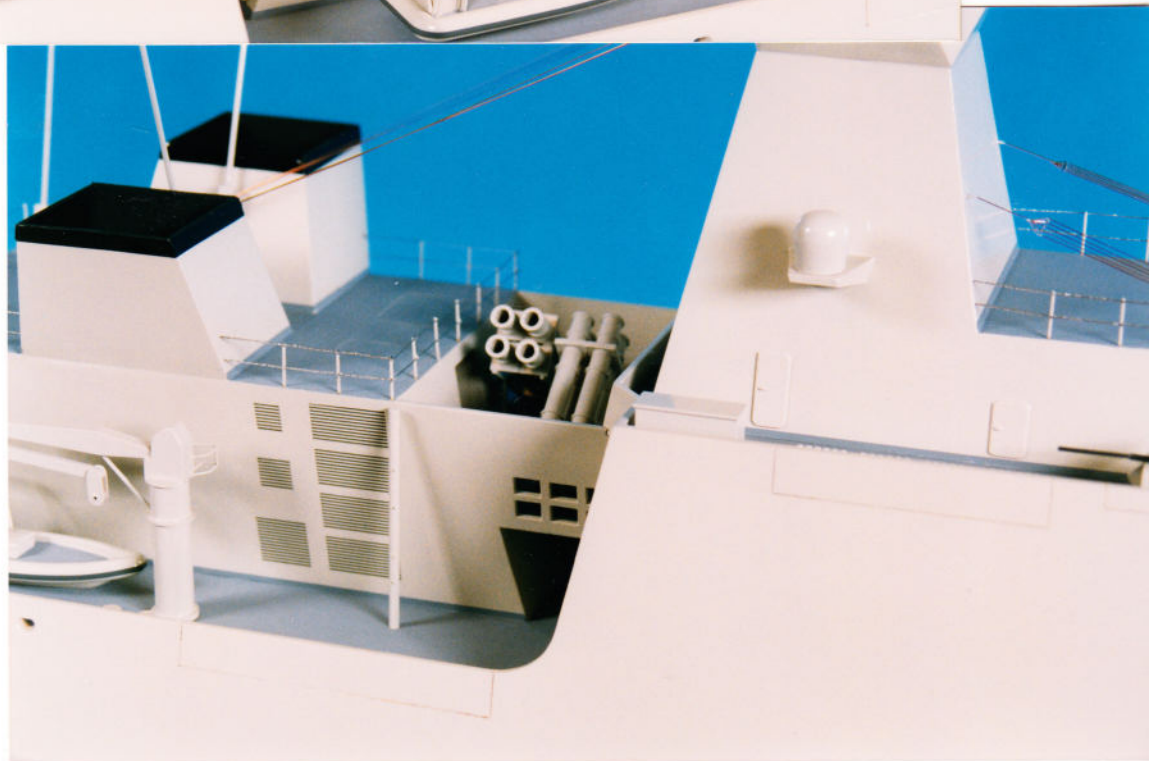
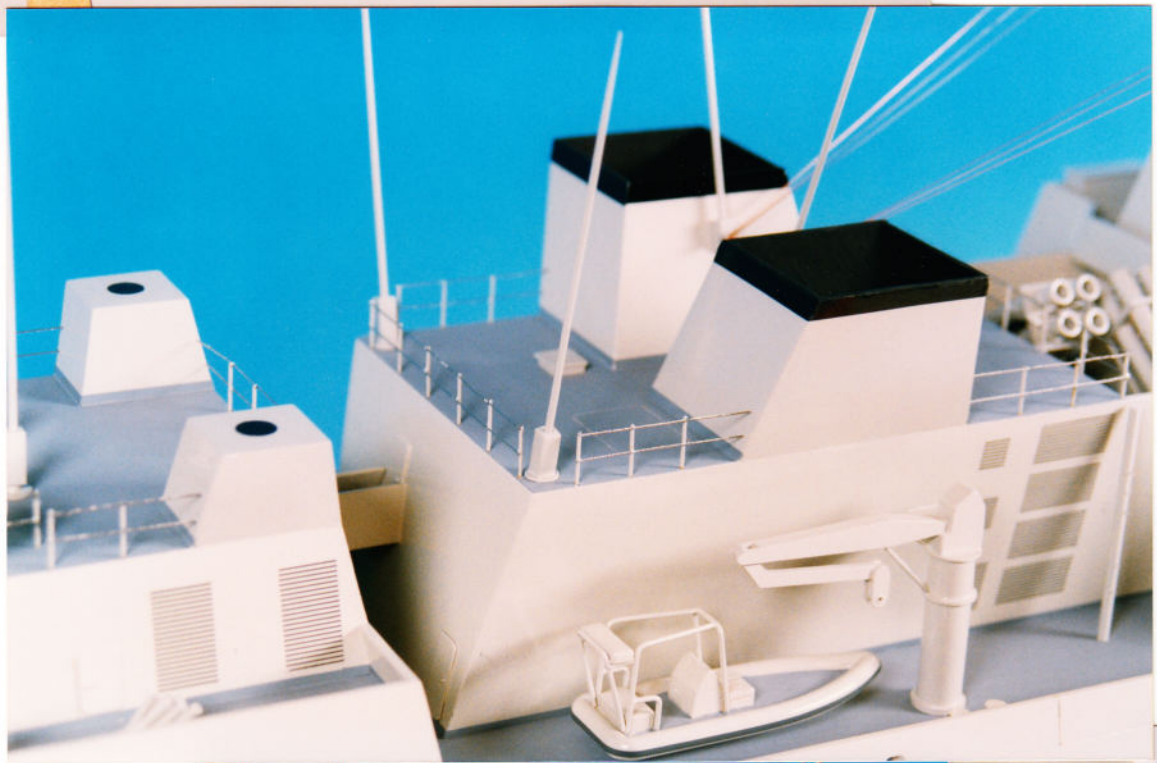

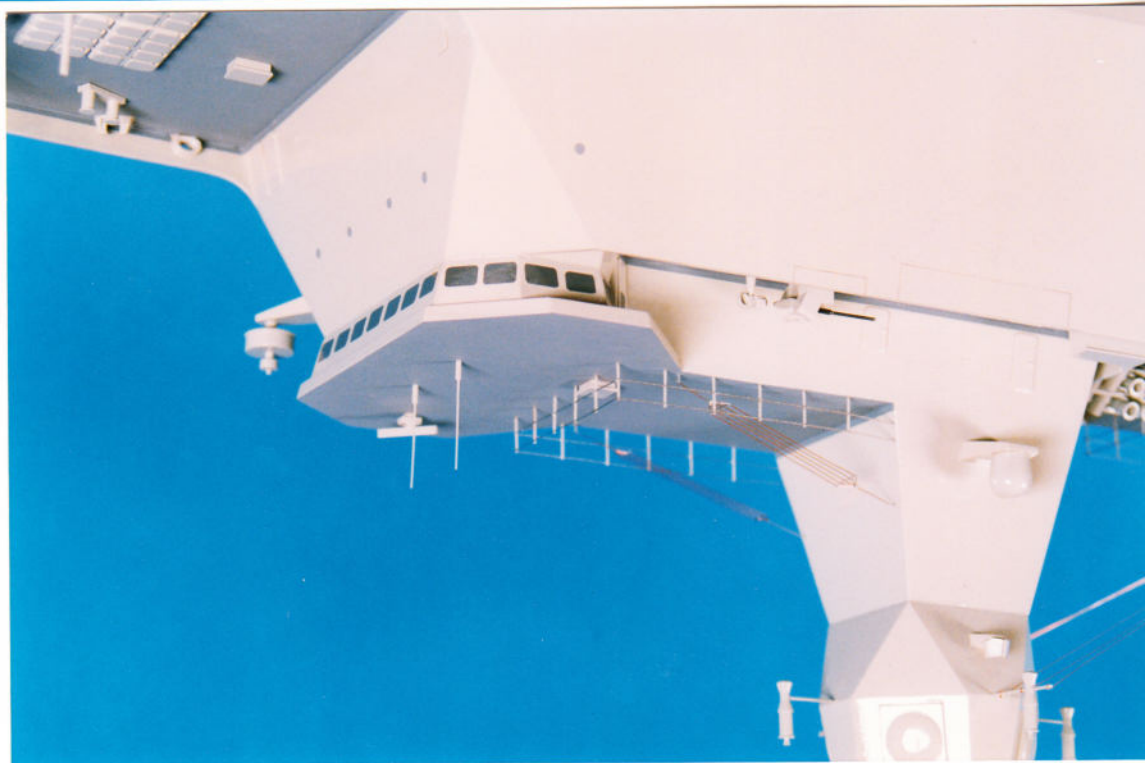
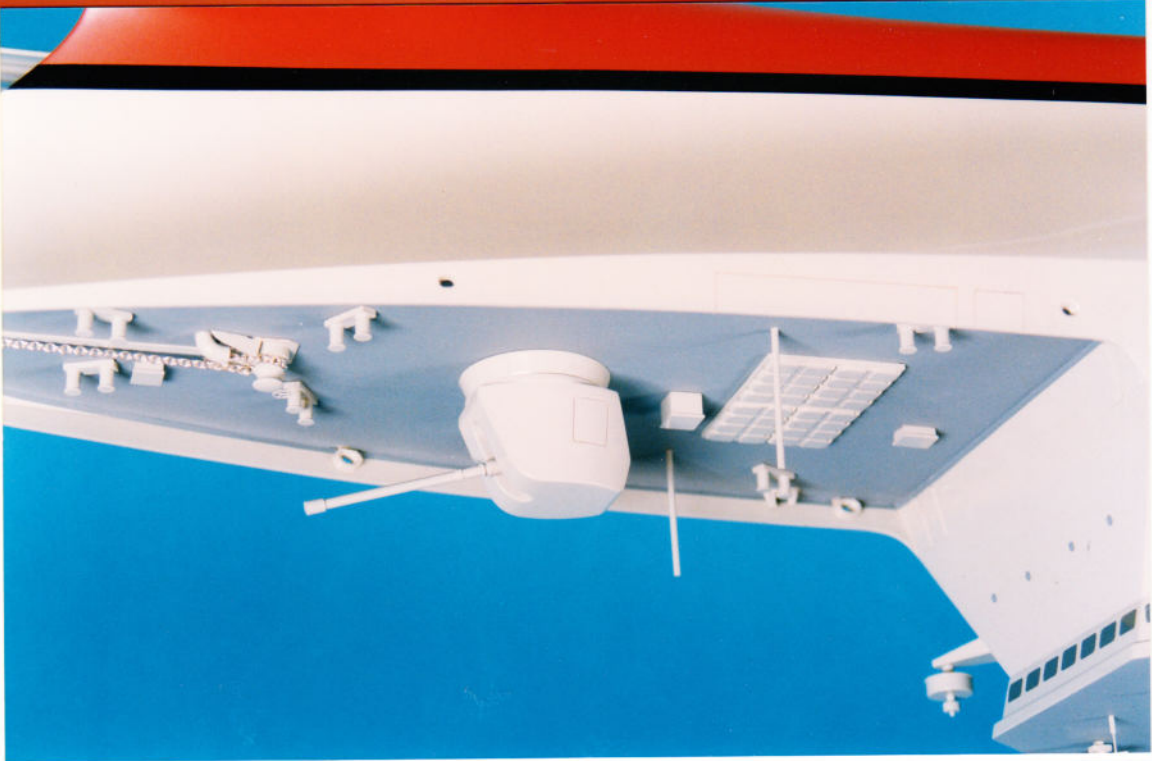
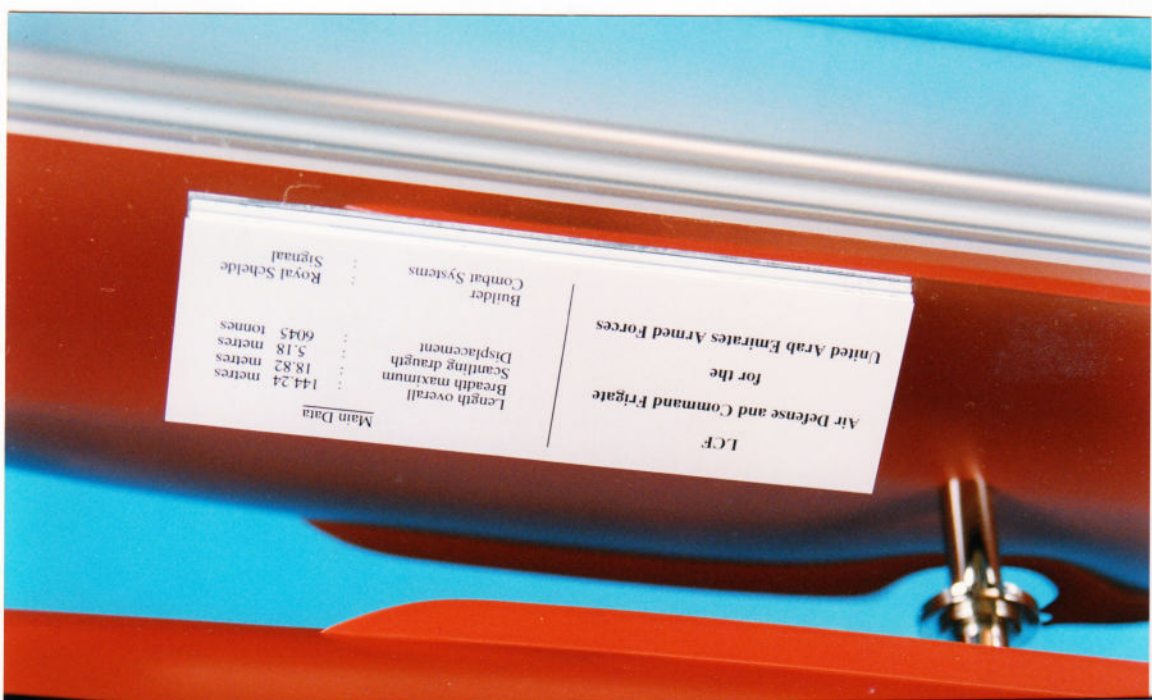

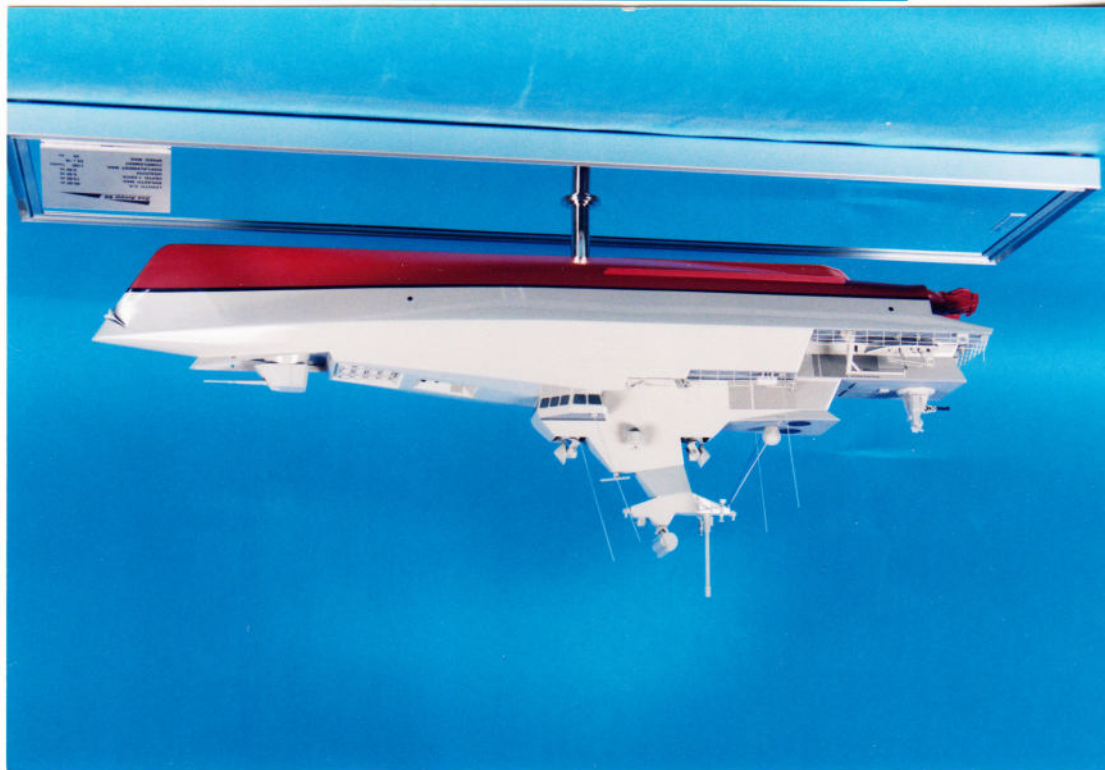
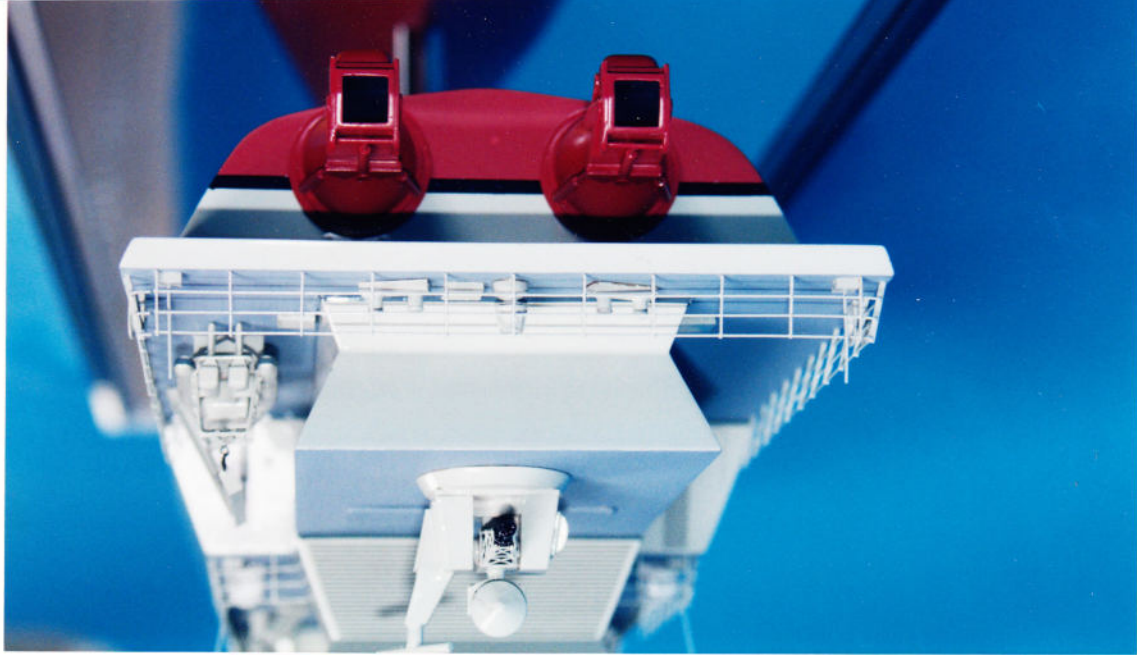
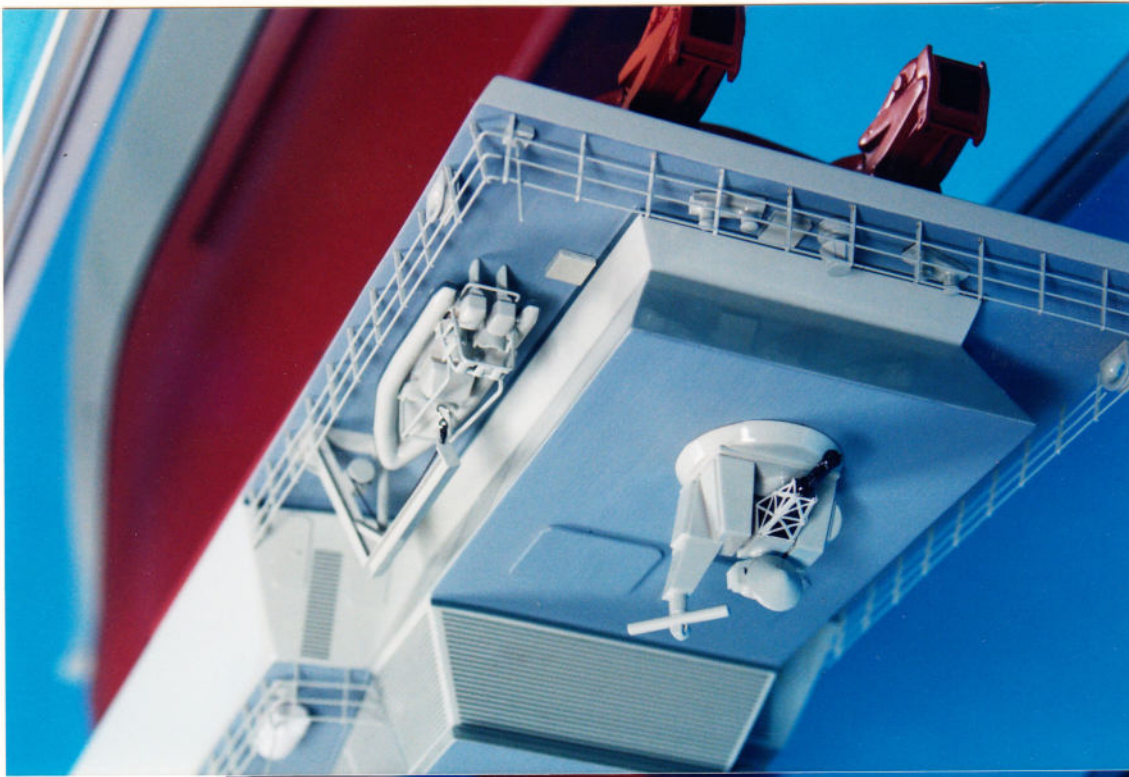

SEA ARCADE
1:100
15/2/97.
289. aus.
(mit mod. Mast
Schip)

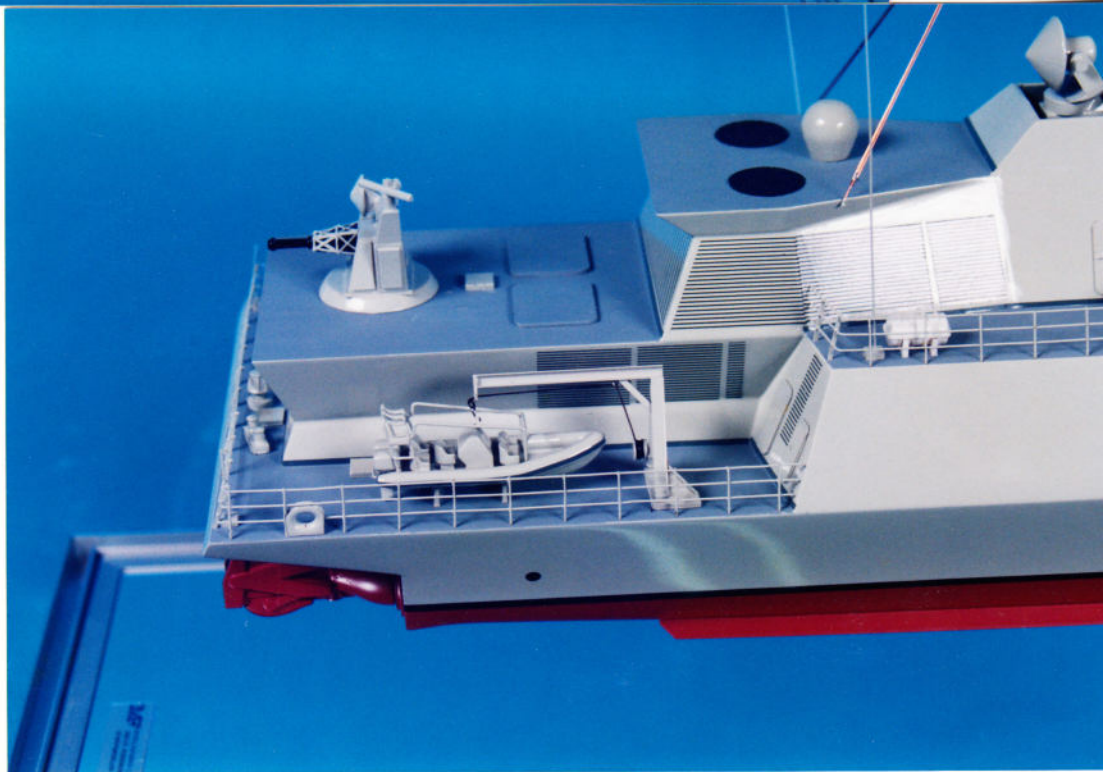
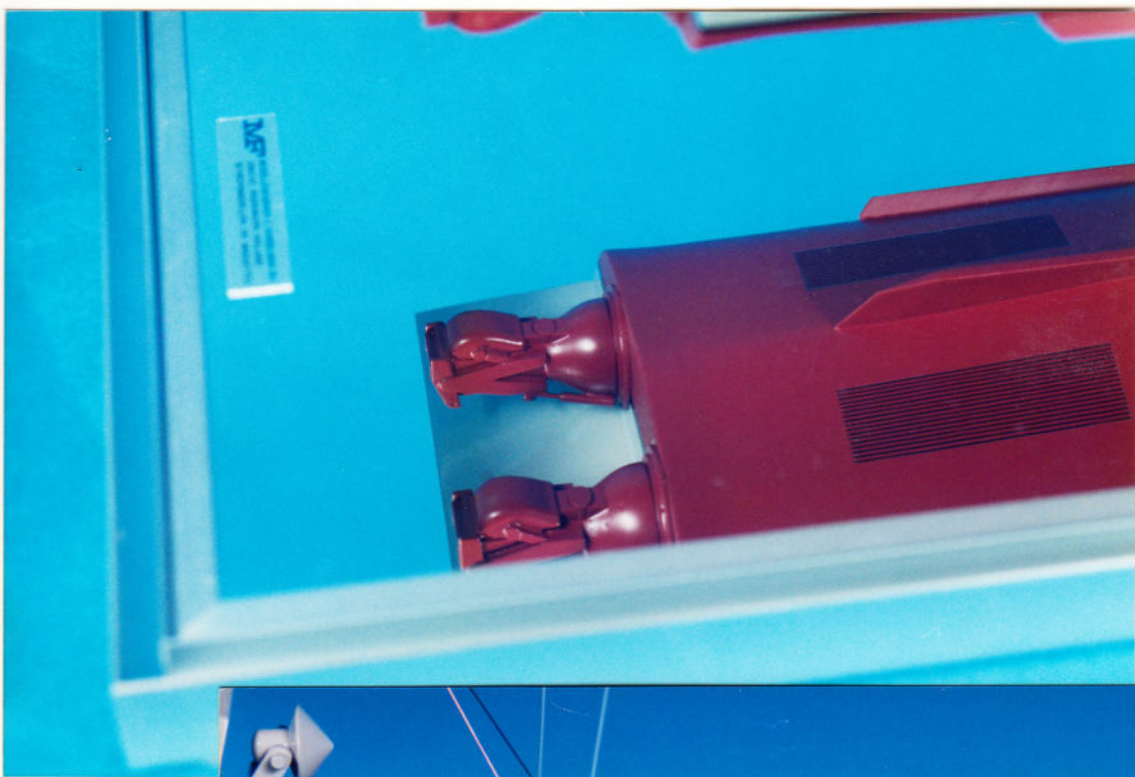

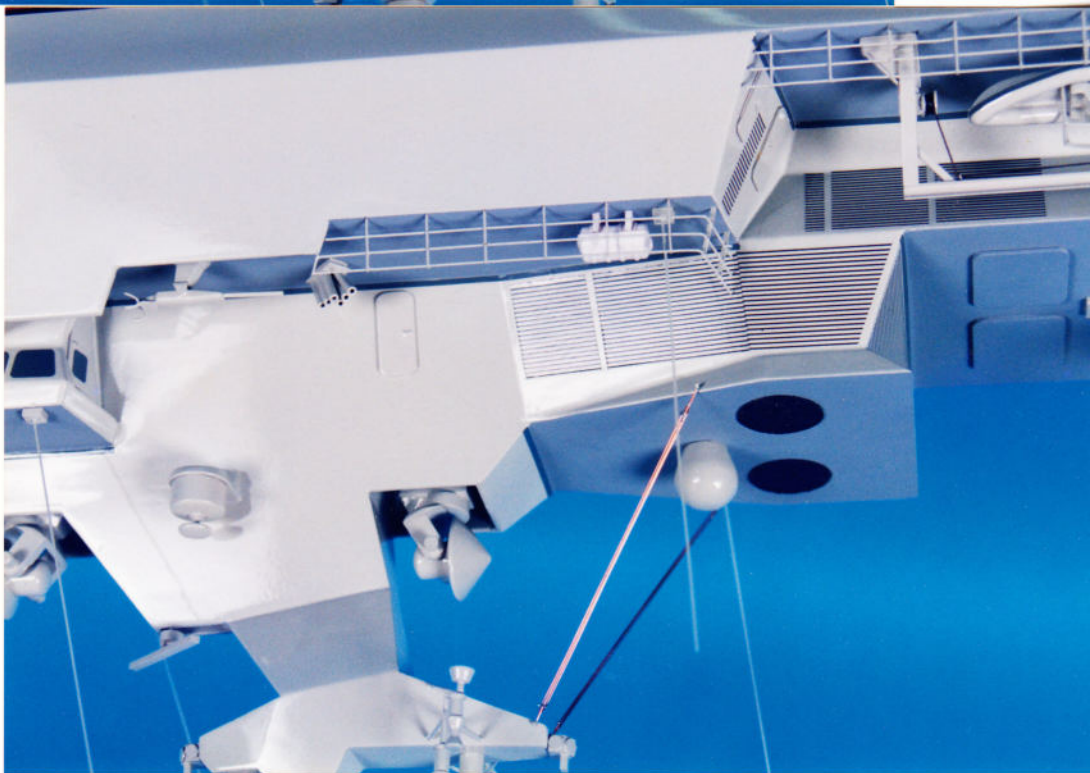
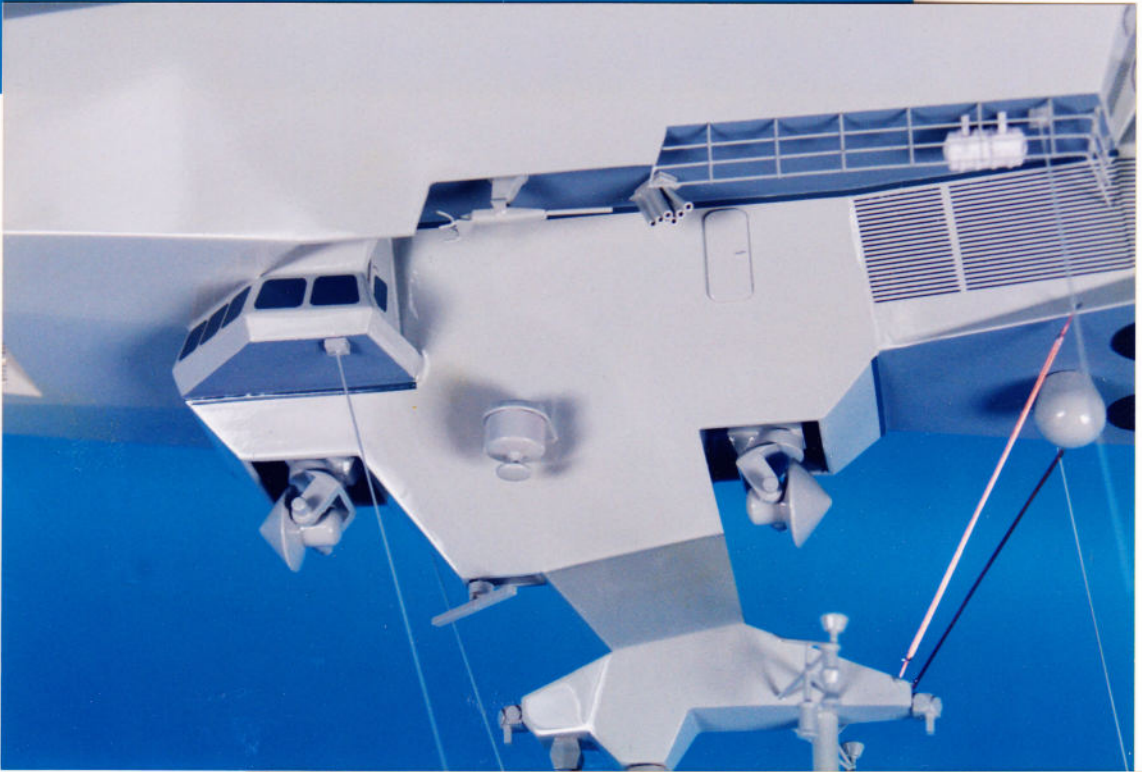
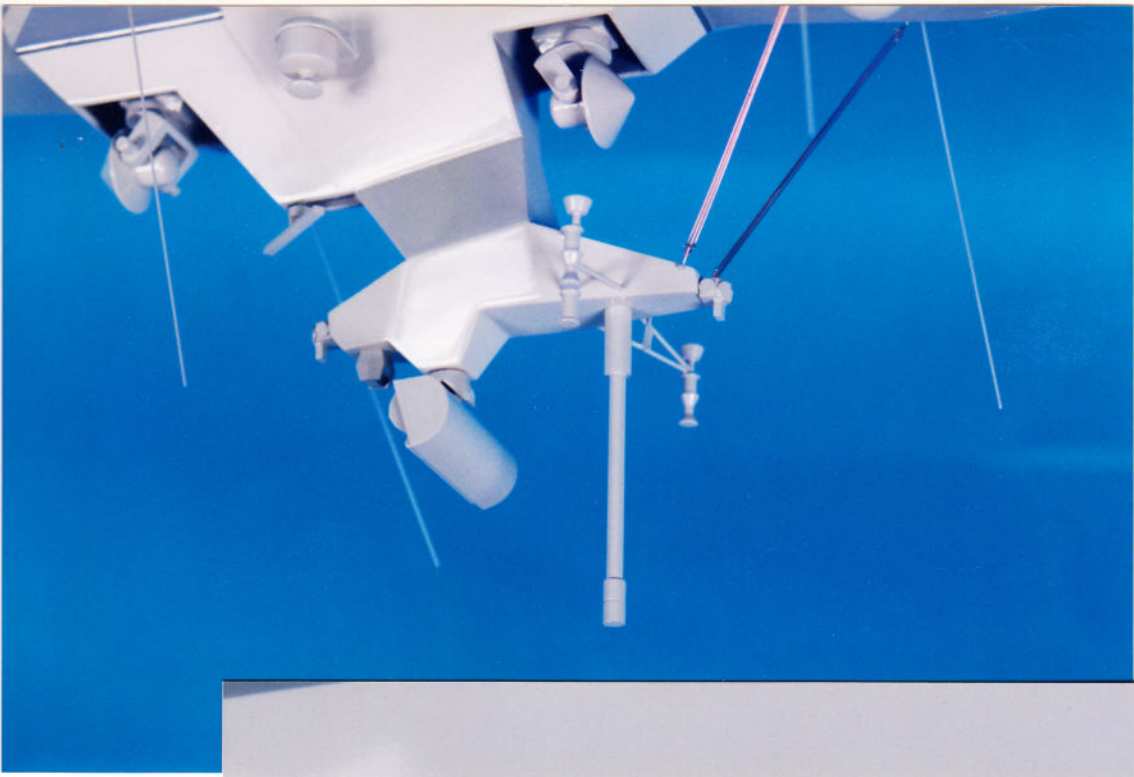

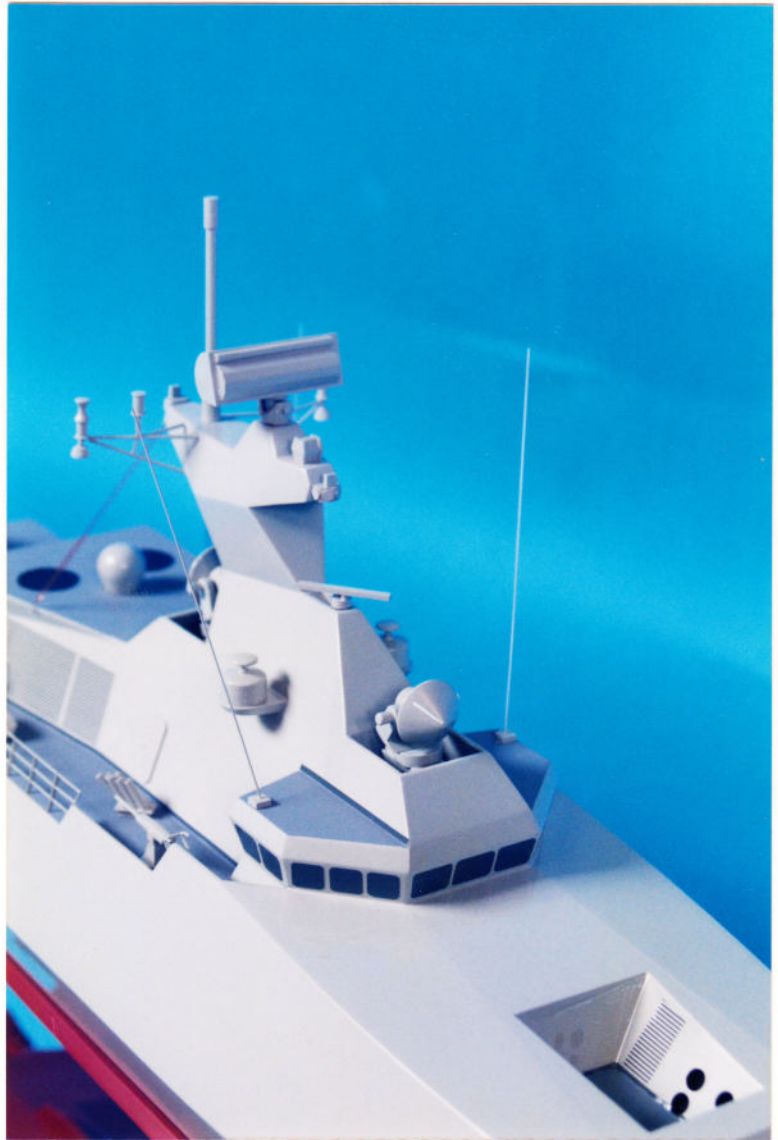



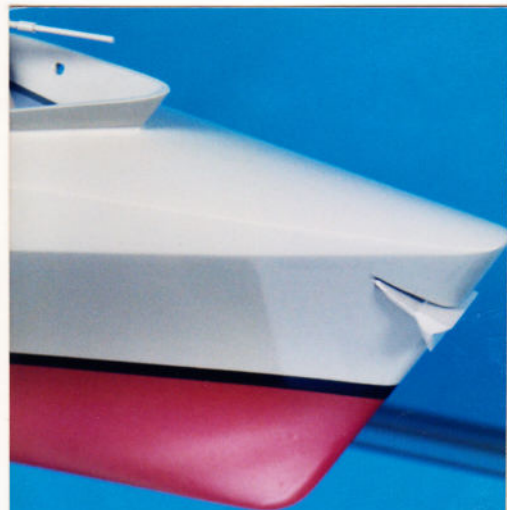

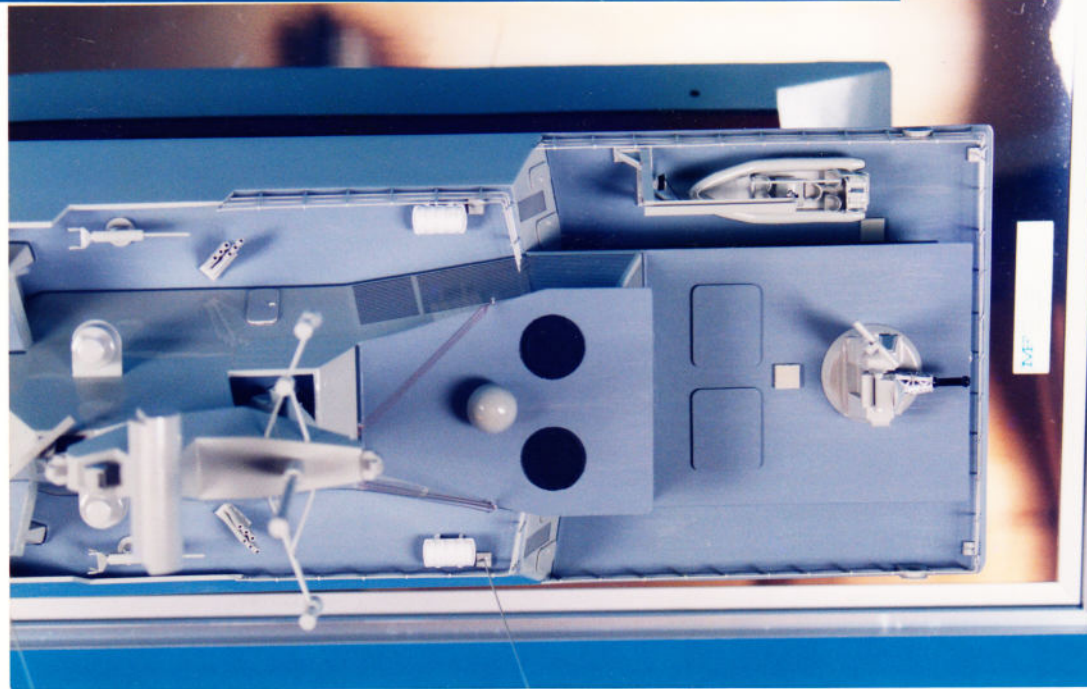
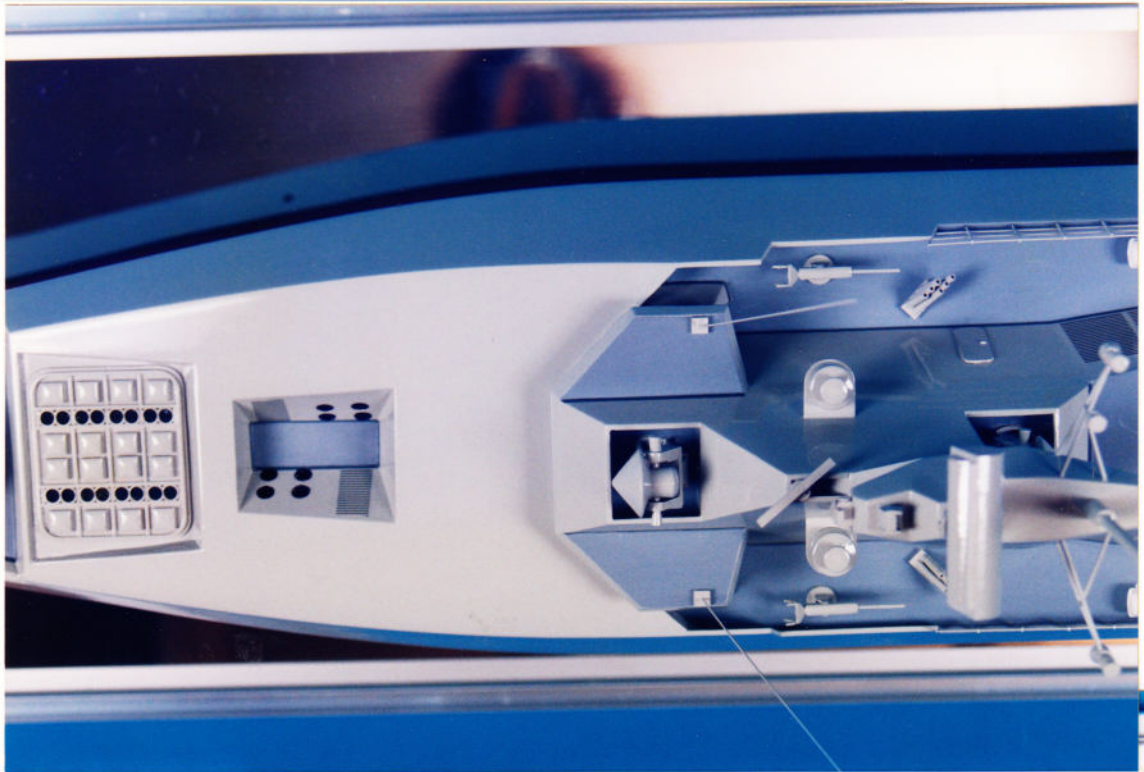



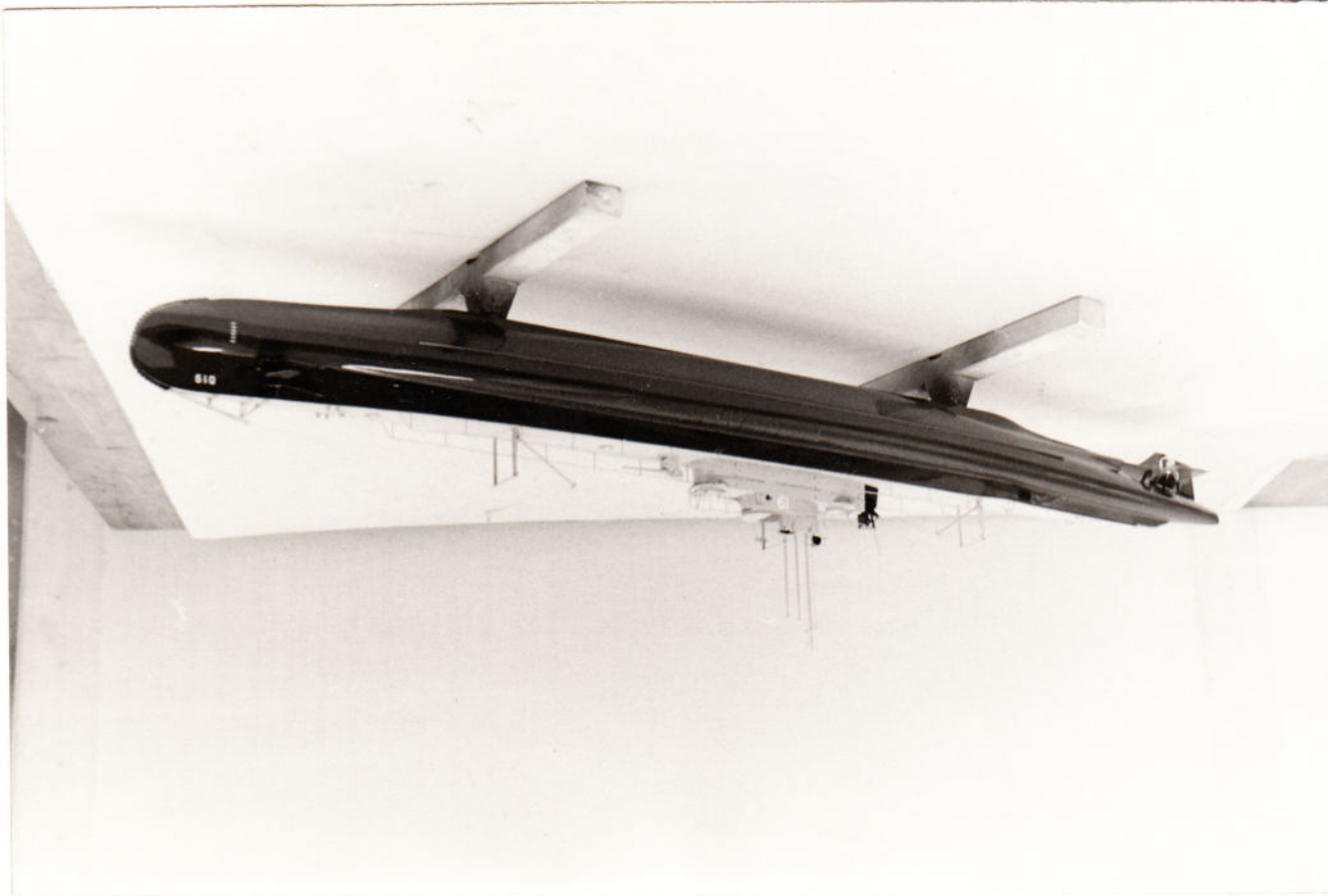
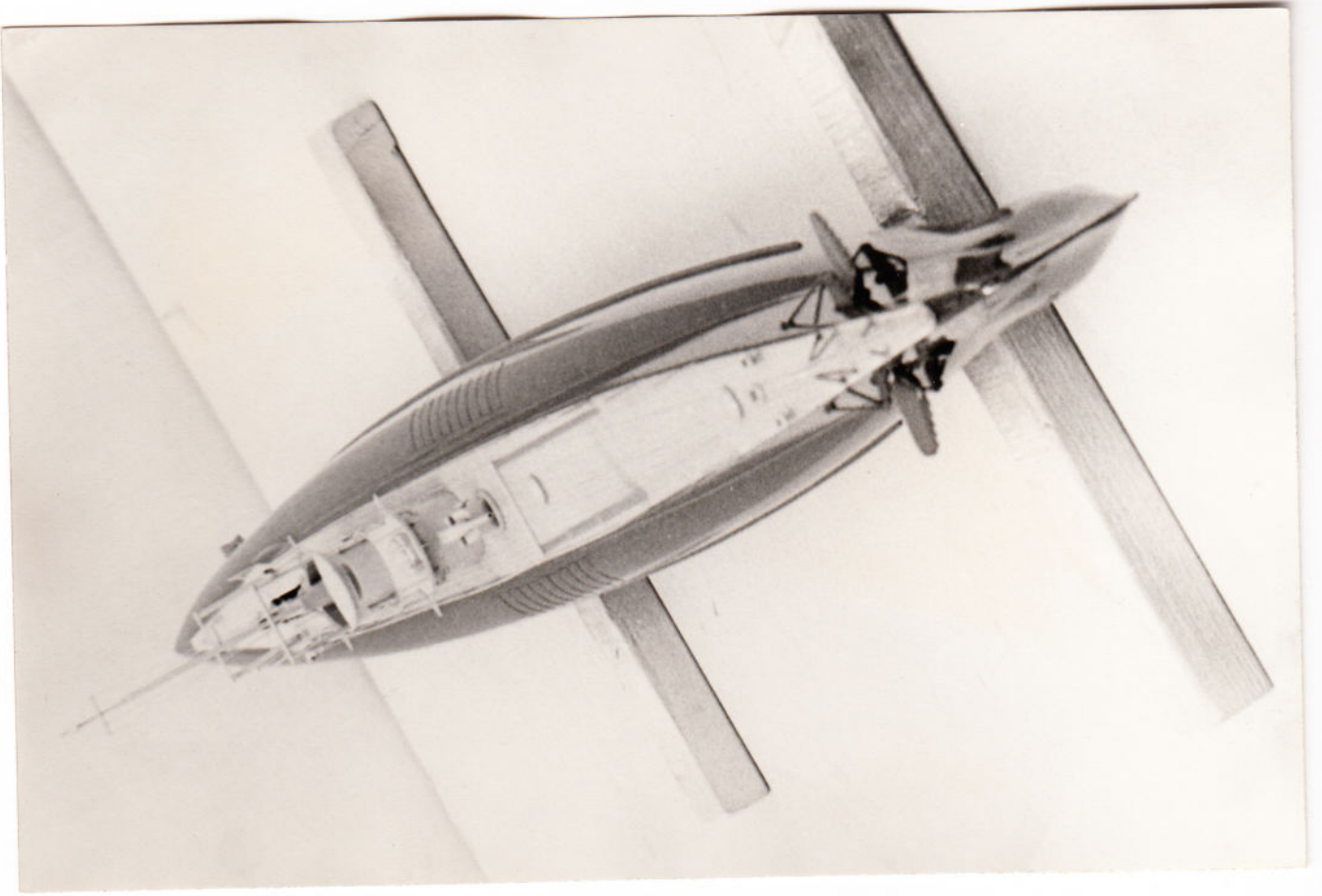

019
2x
1965
NEWSBY
1:100

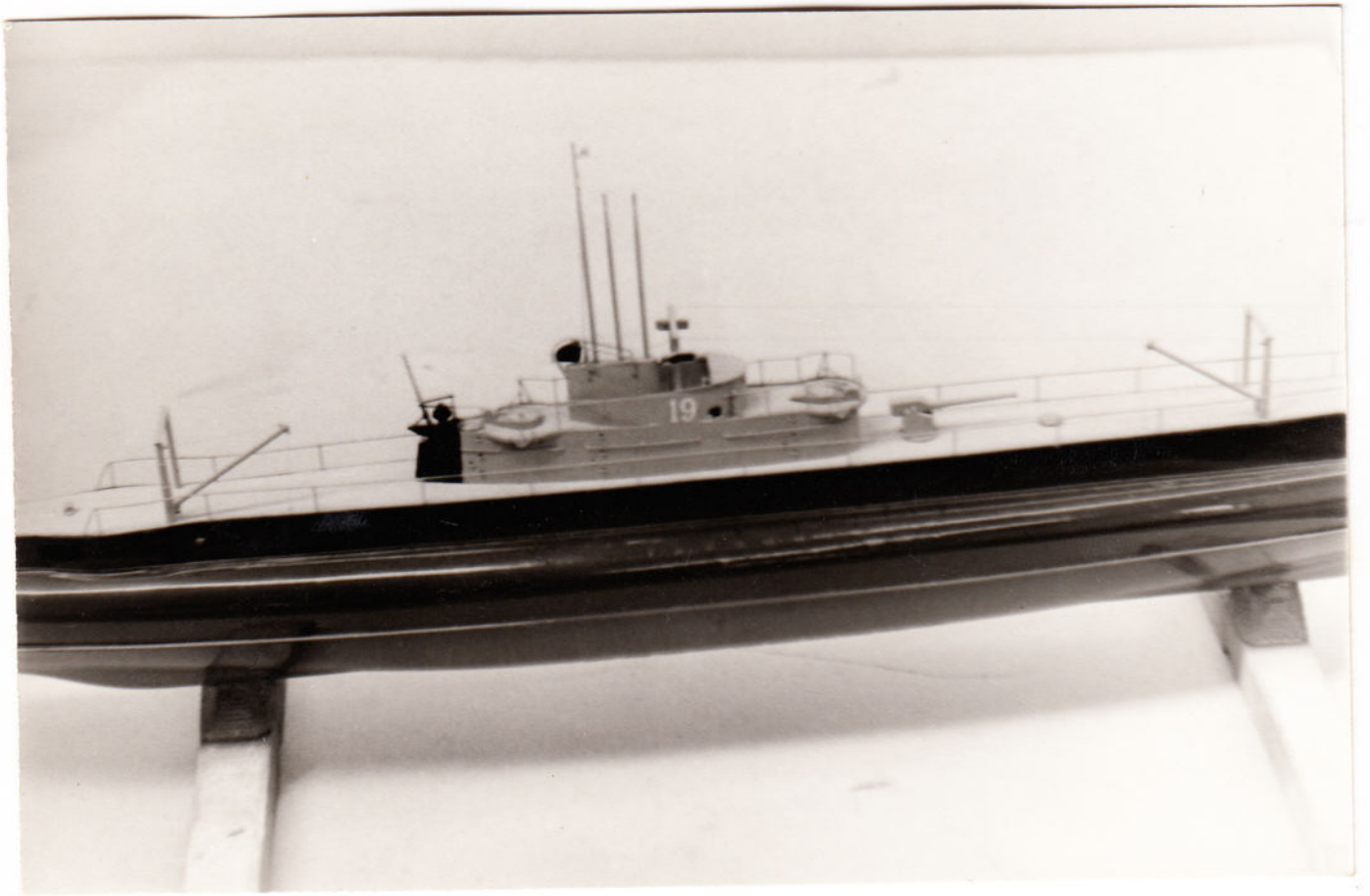
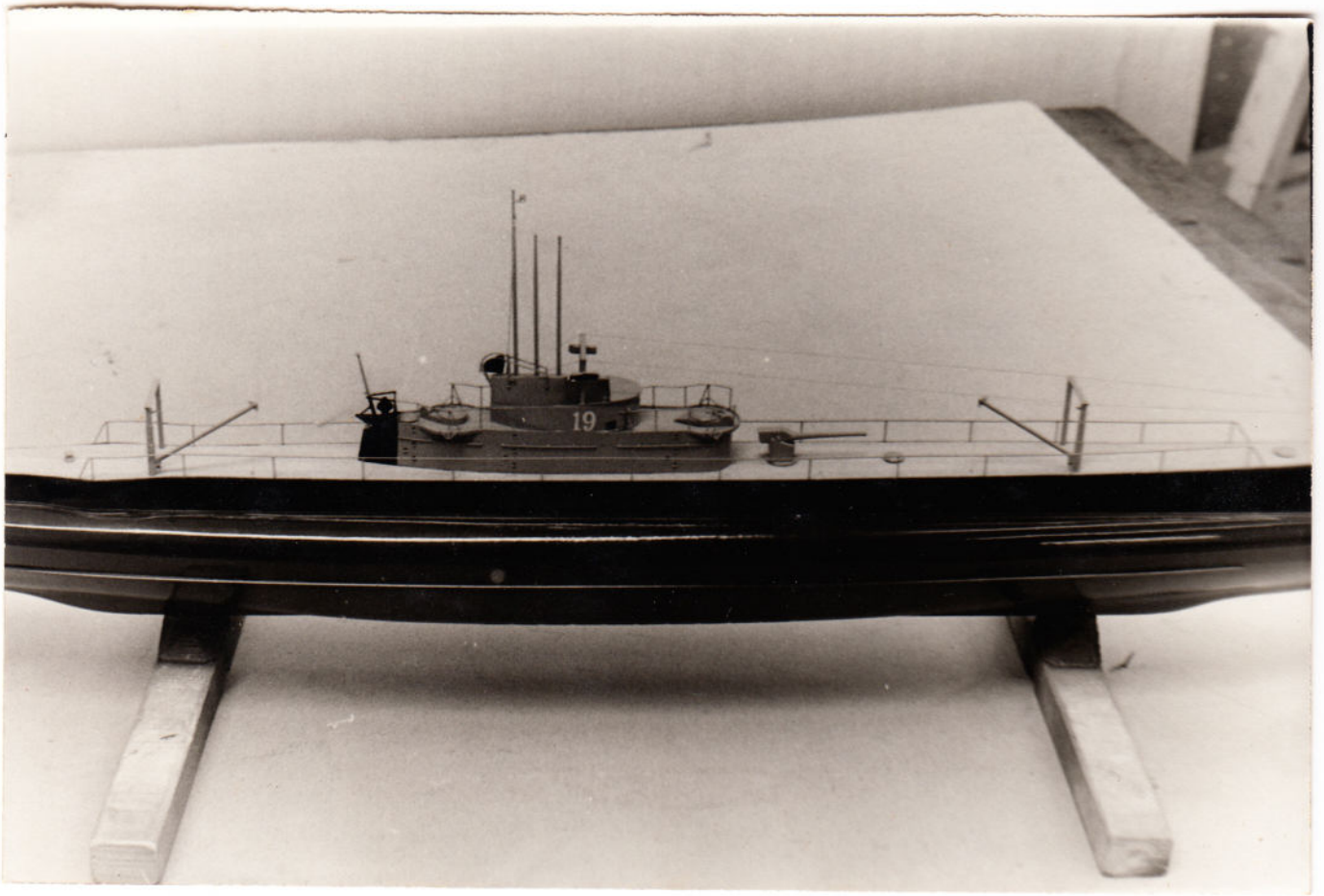

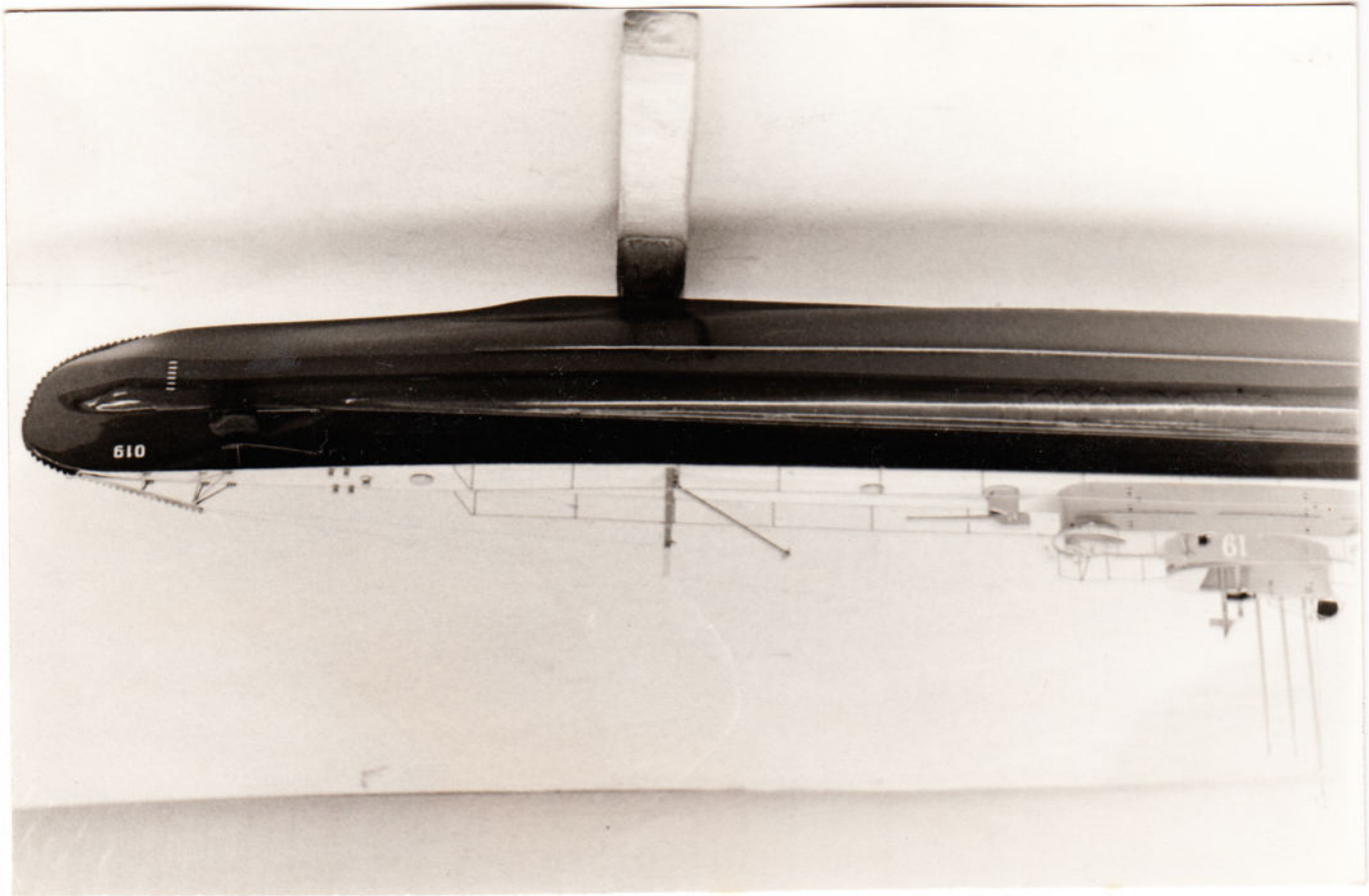
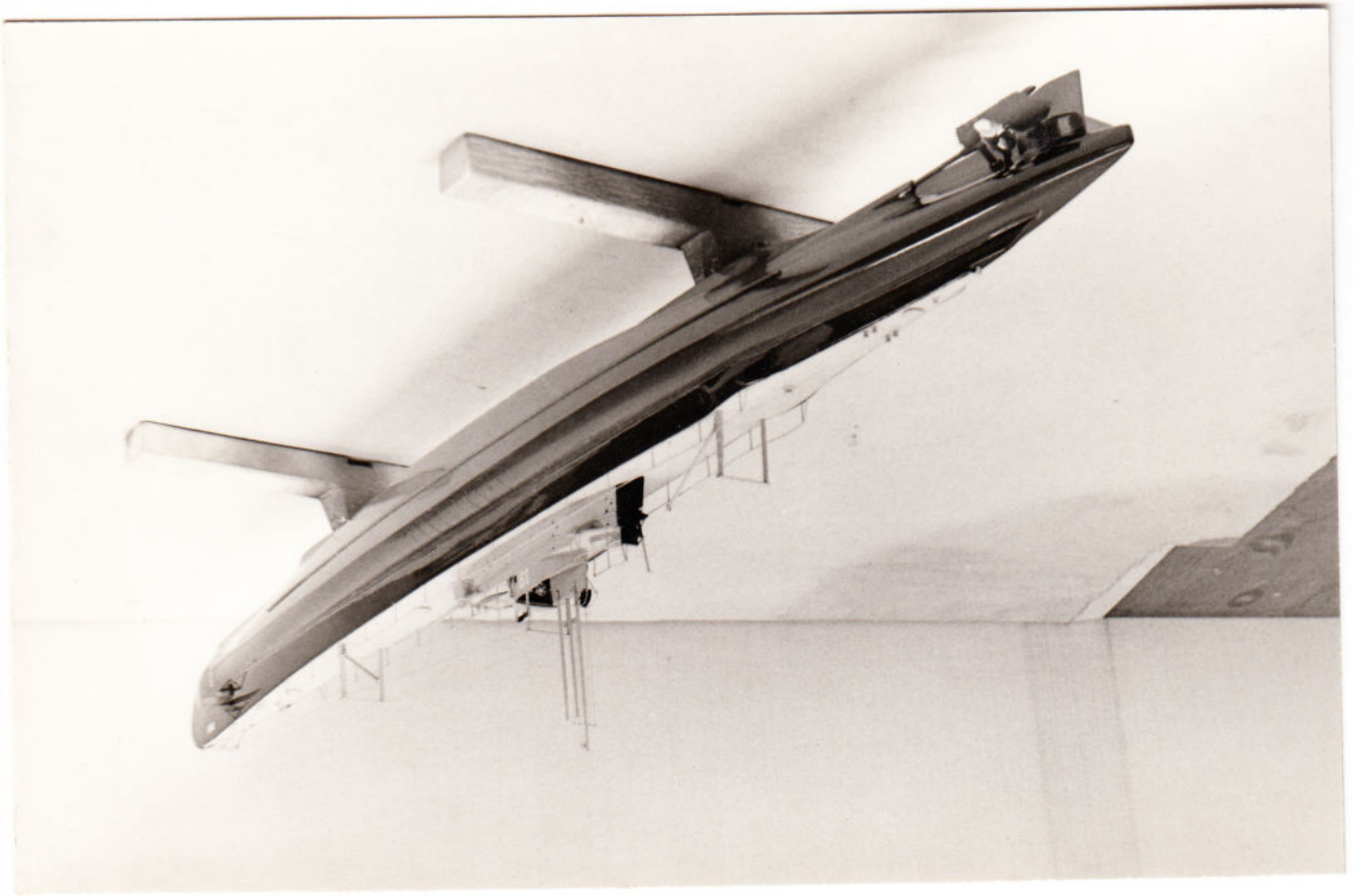

Marine

1966

Potuis +

doornsteden

1840

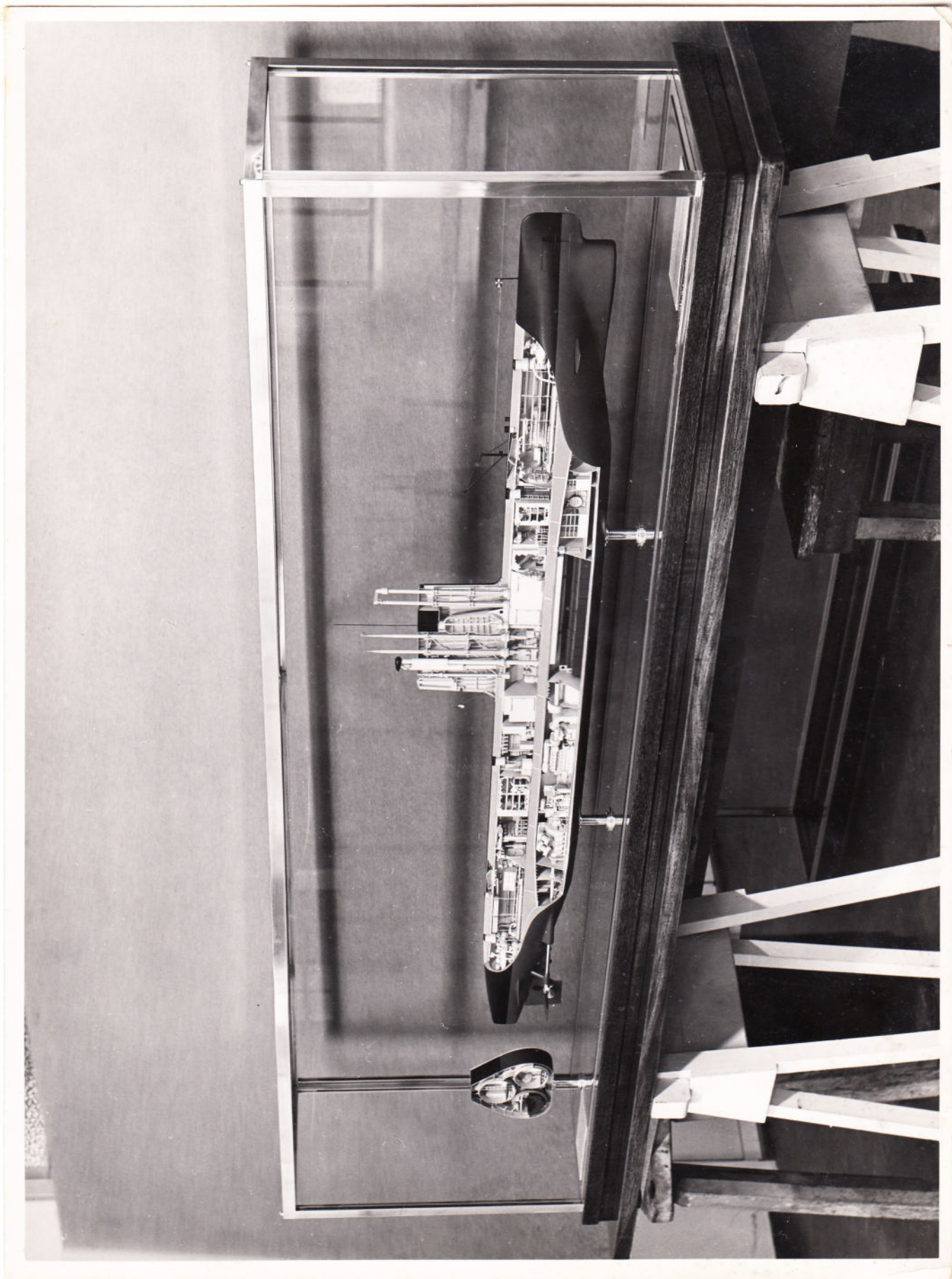

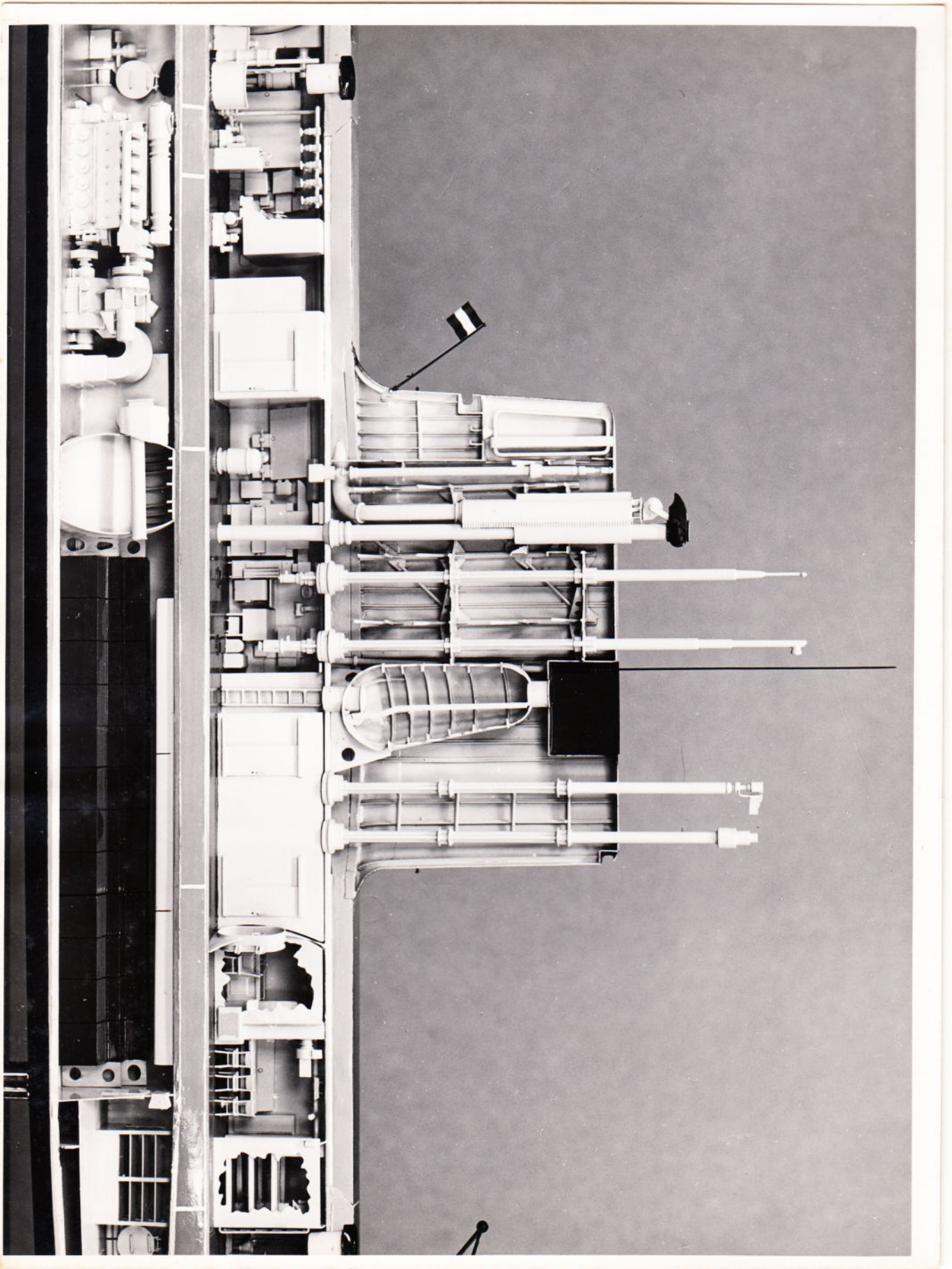

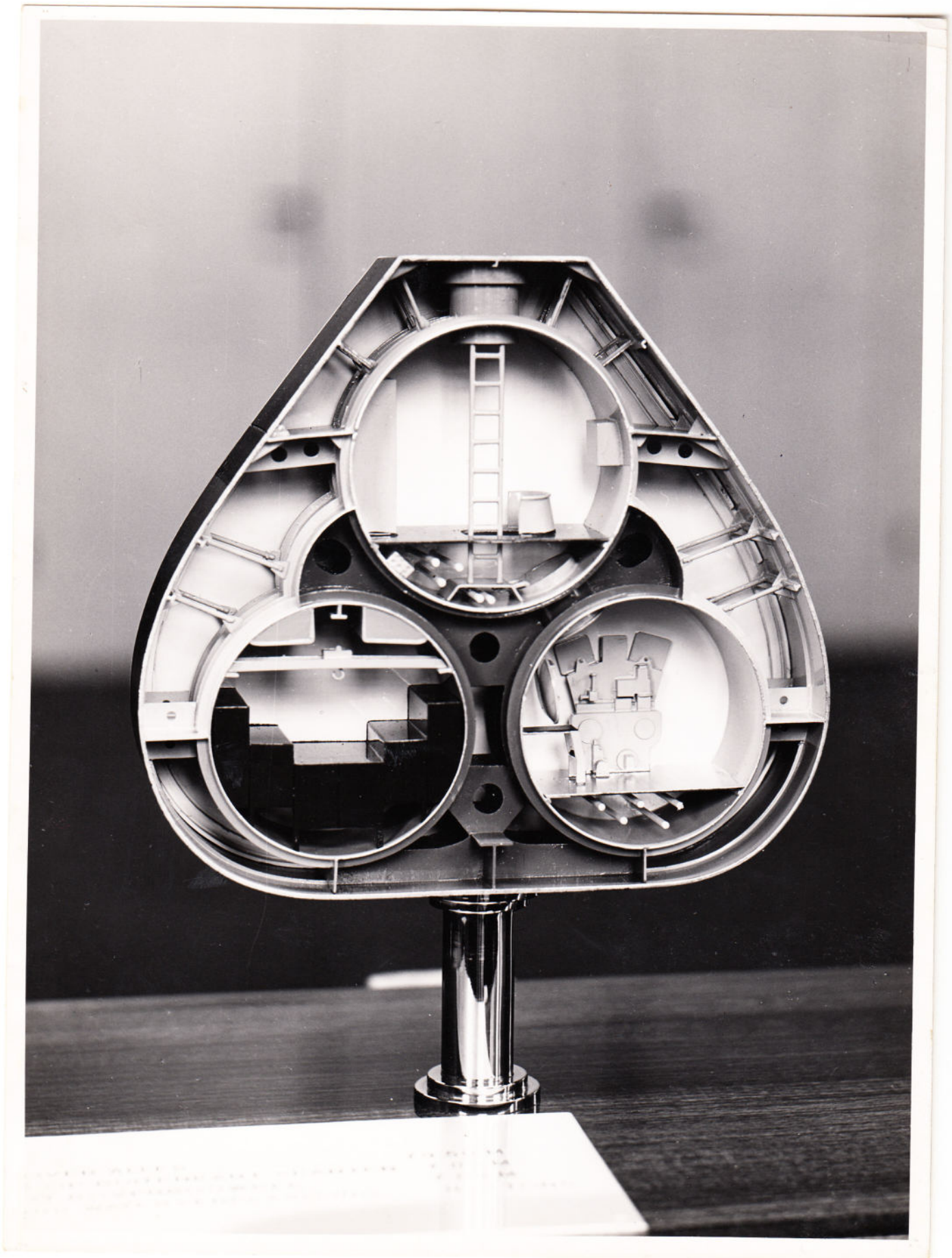



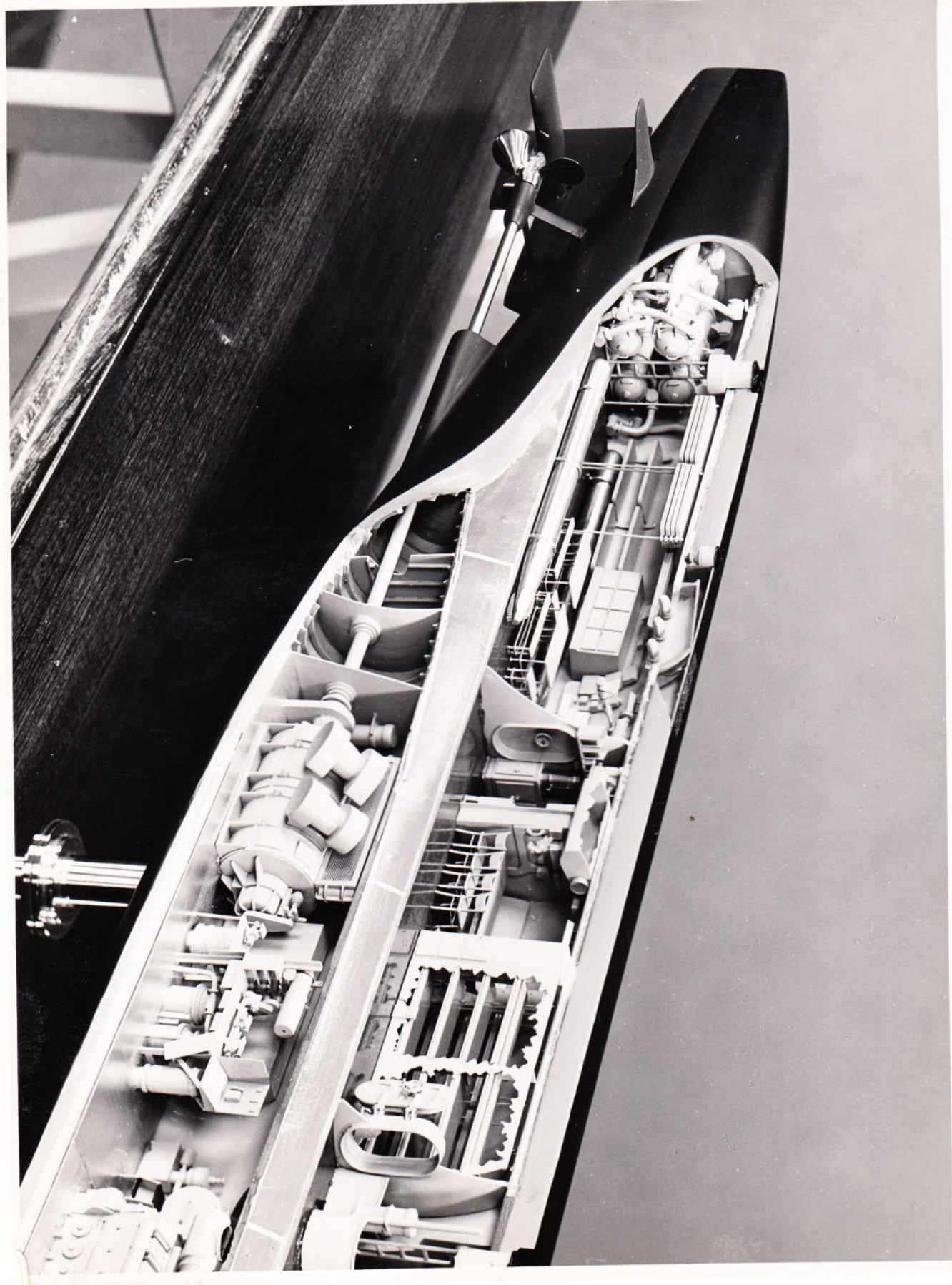

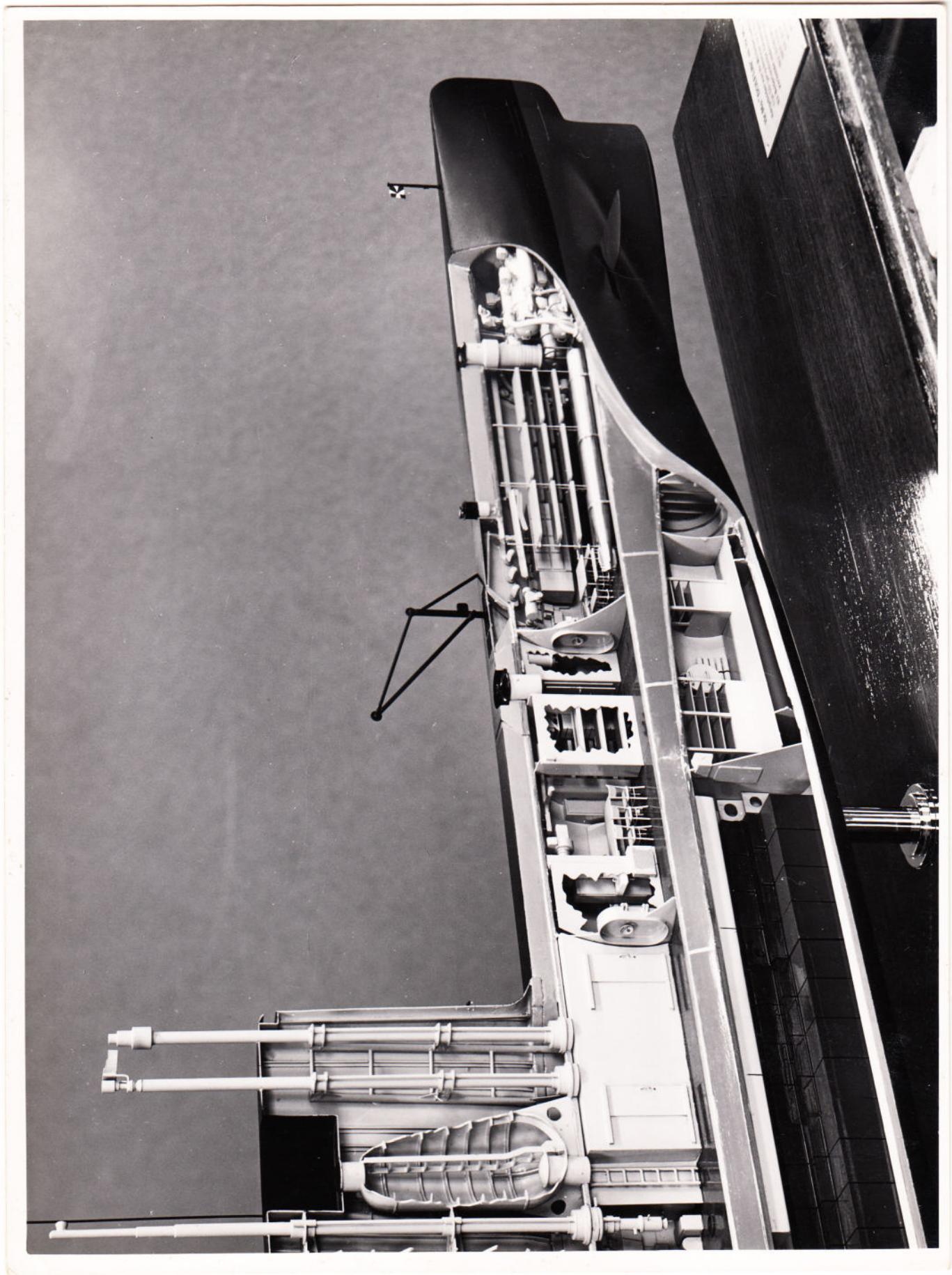

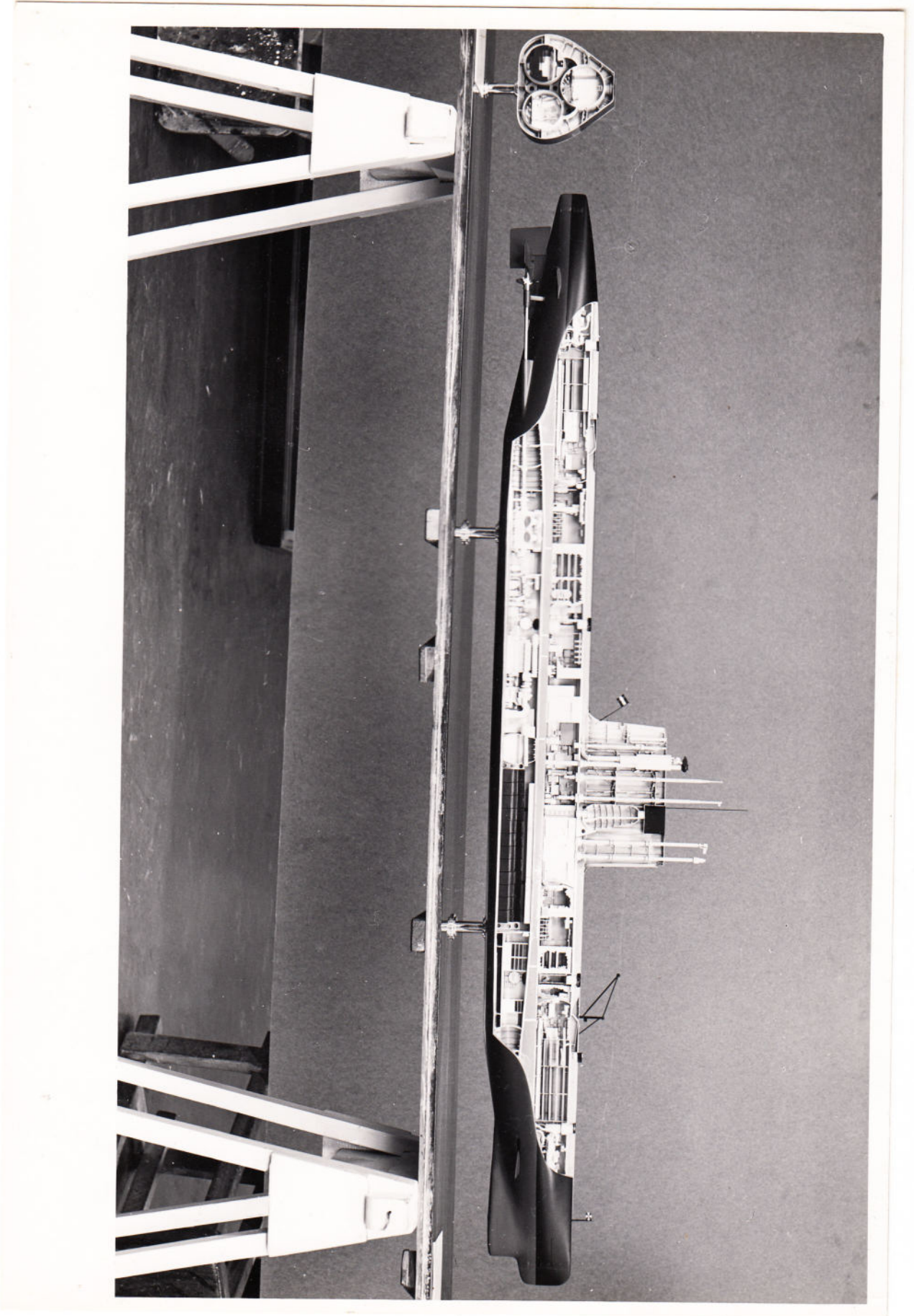

PSTUIS
1966

INSTRUCTIE MODEL ~~REDA~~ ROTUIS 1966











ZWAARDUIS

1972

1:50

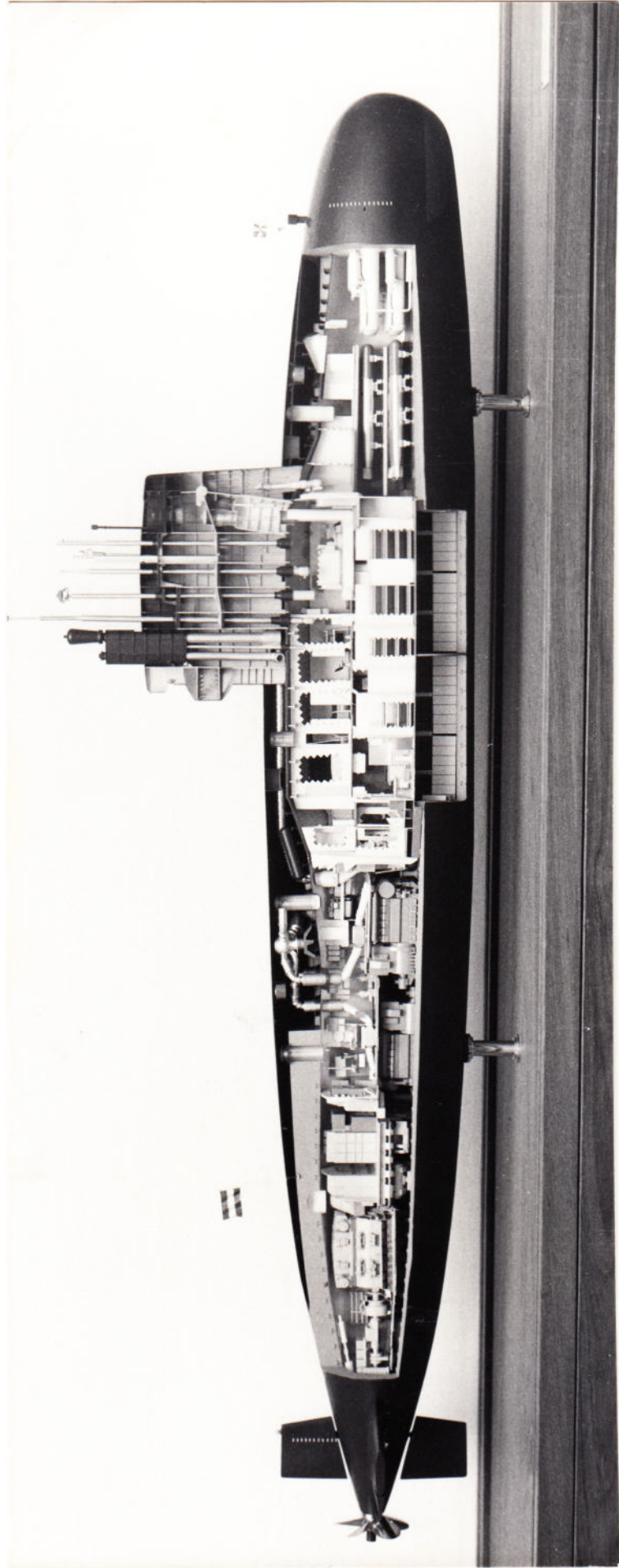

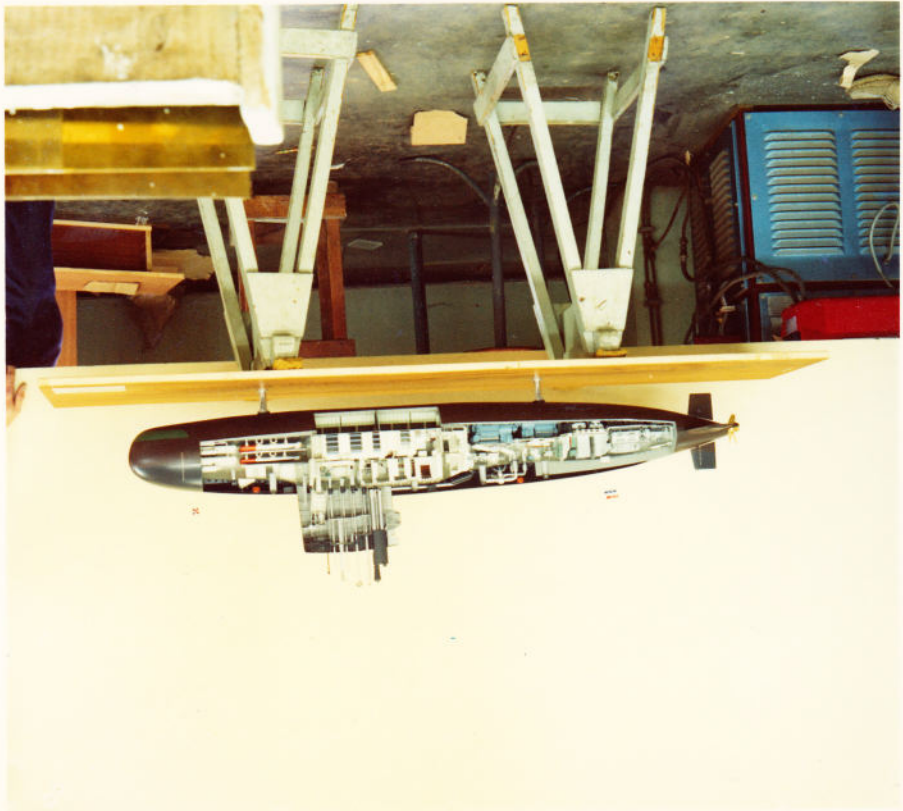

1972

ESMARDVIS

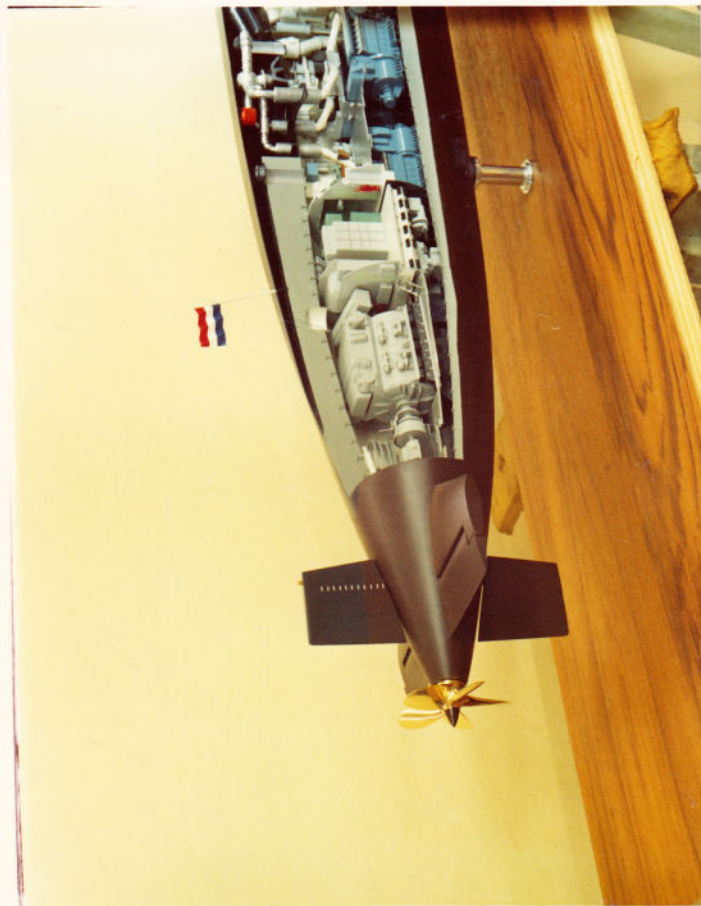
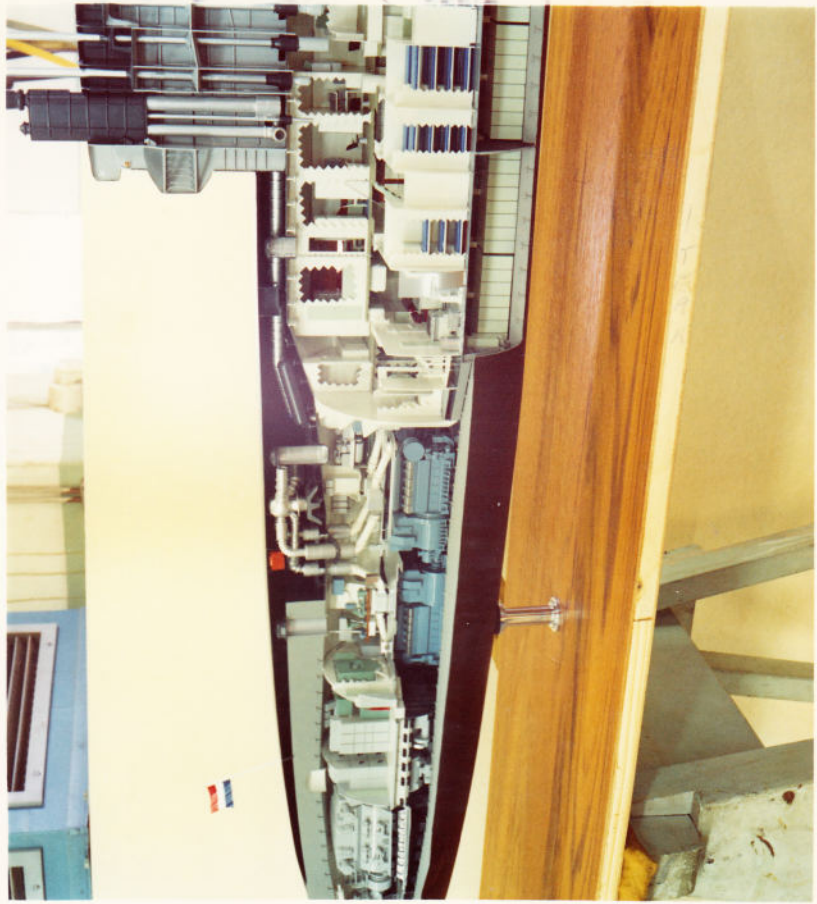
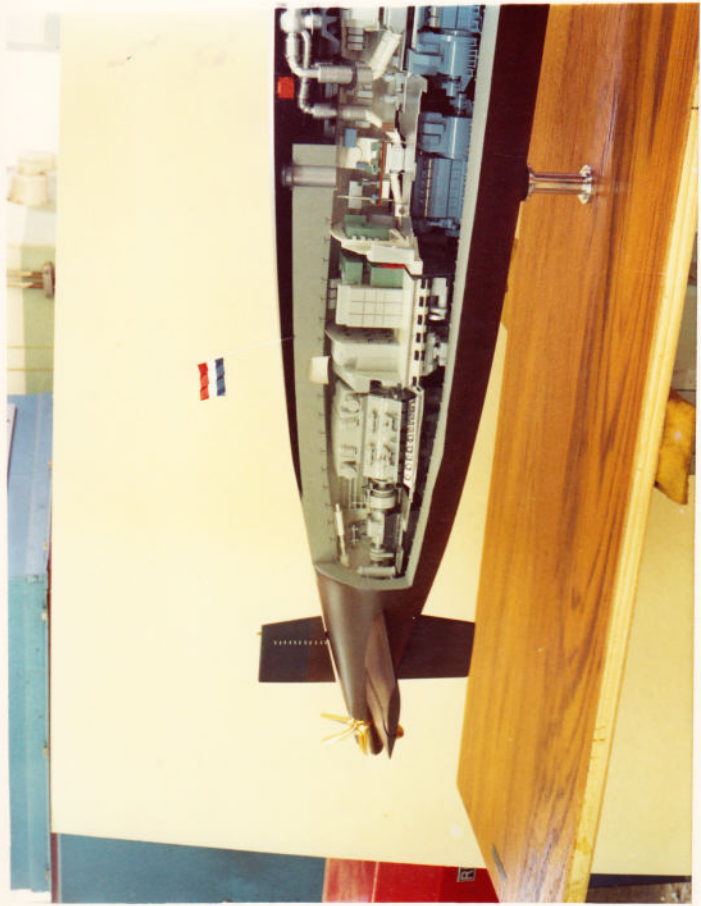

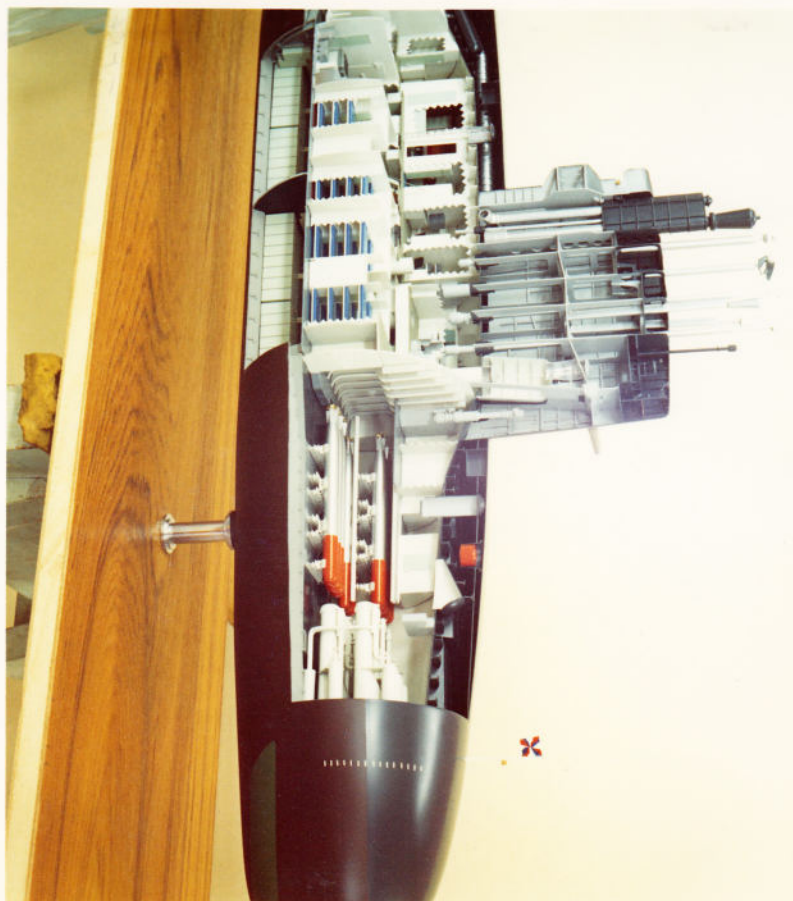
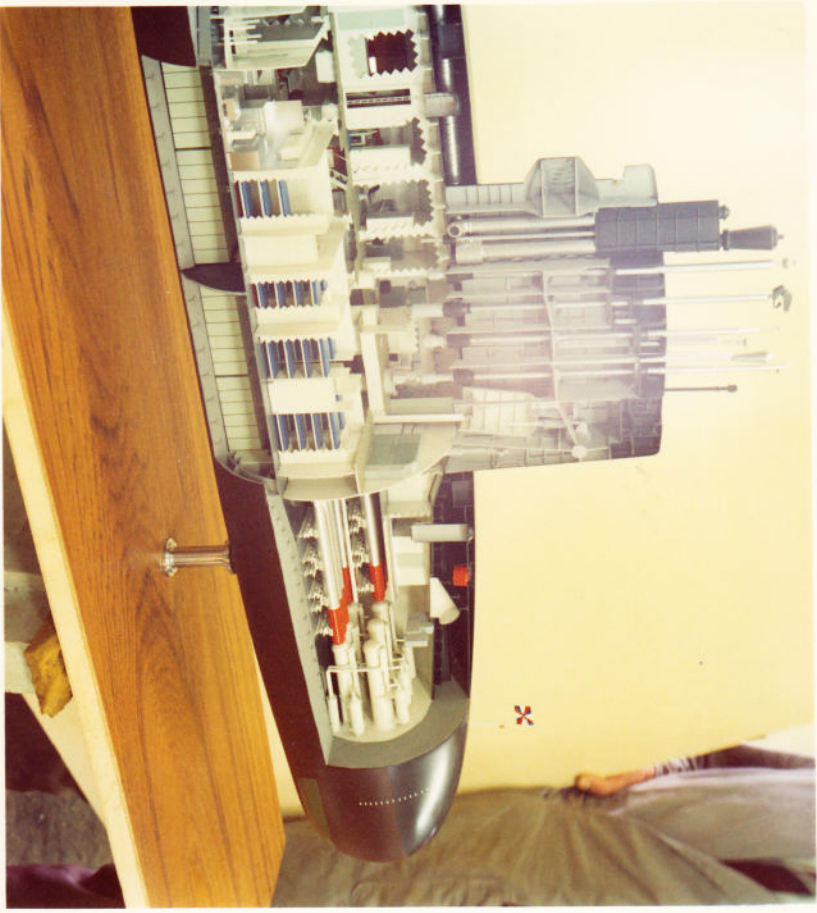





1100



1800



1400

1800

2x MORA 1100
 2x MORA 1400
 2x MORA 1800 + mod. 1.100
 15 1/2 / 85
 2 1/2 cur.

3x MORA 1400
 1x MORA 1100 + mod. 1.100
 16/5 / 86
 95% cur.

3x MORA 1400 + mod. 1.100
 7/6 / 85
 104 cur.

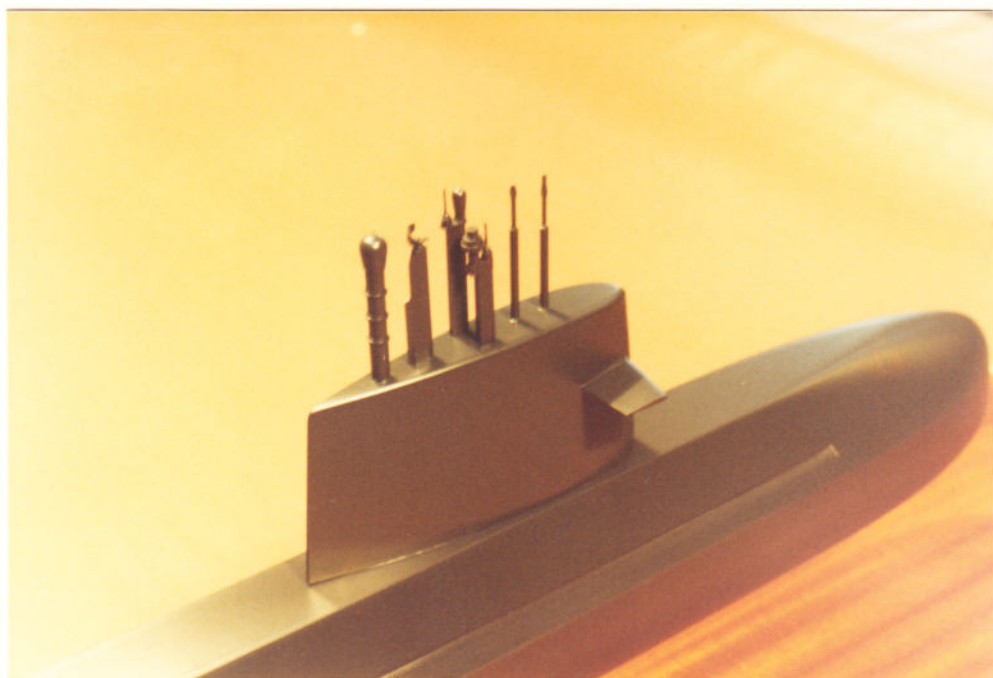

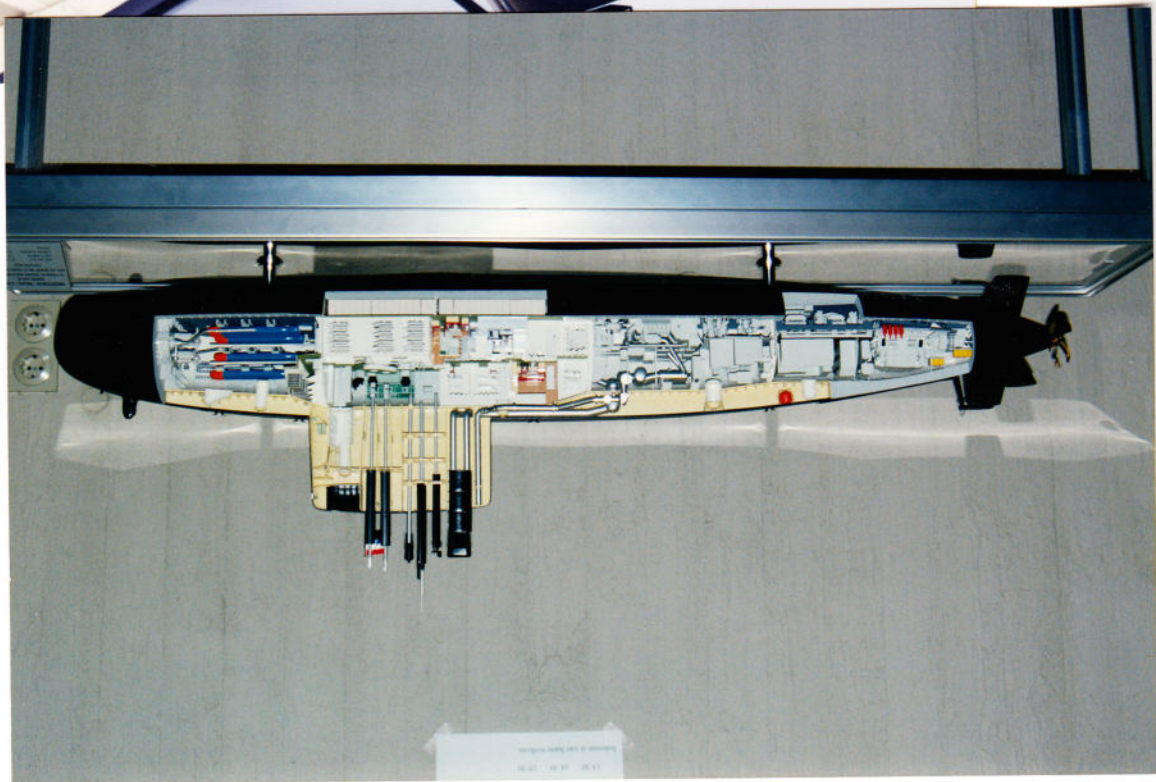
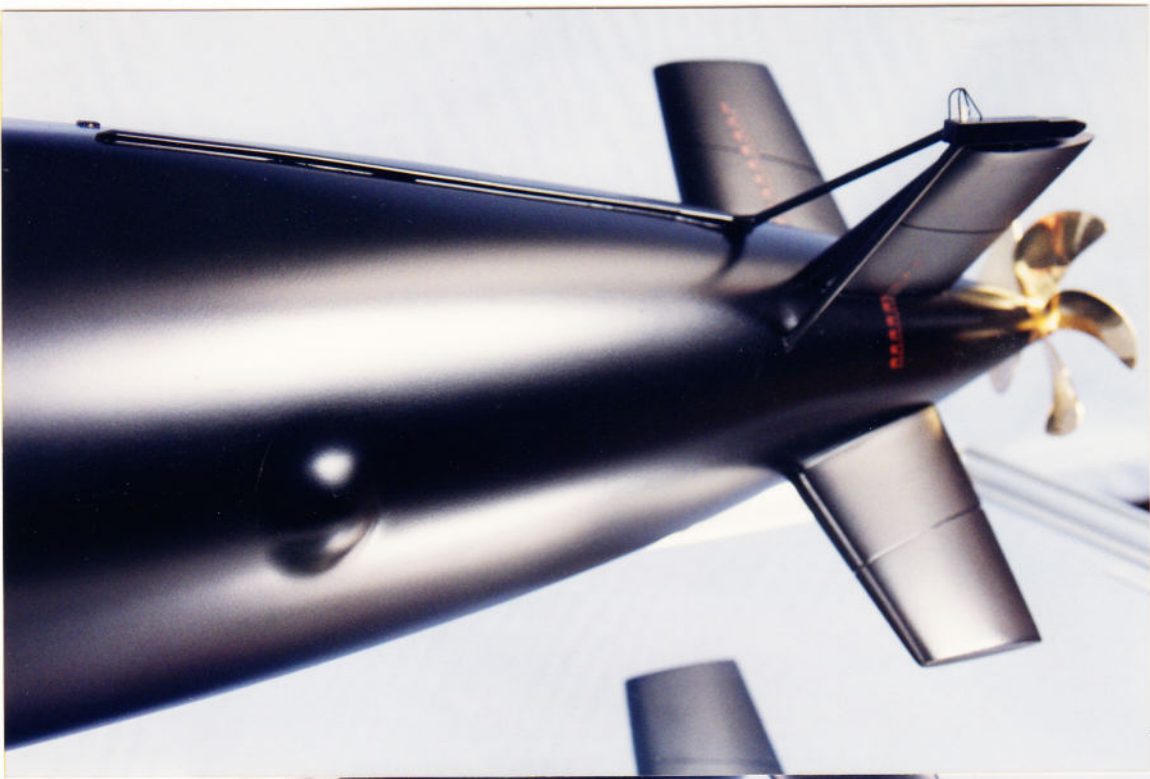

U-100

(Kees Leijter)
(Piet Weisfelt)

5/12/92

2 van der Zee's

1:50

MARINE

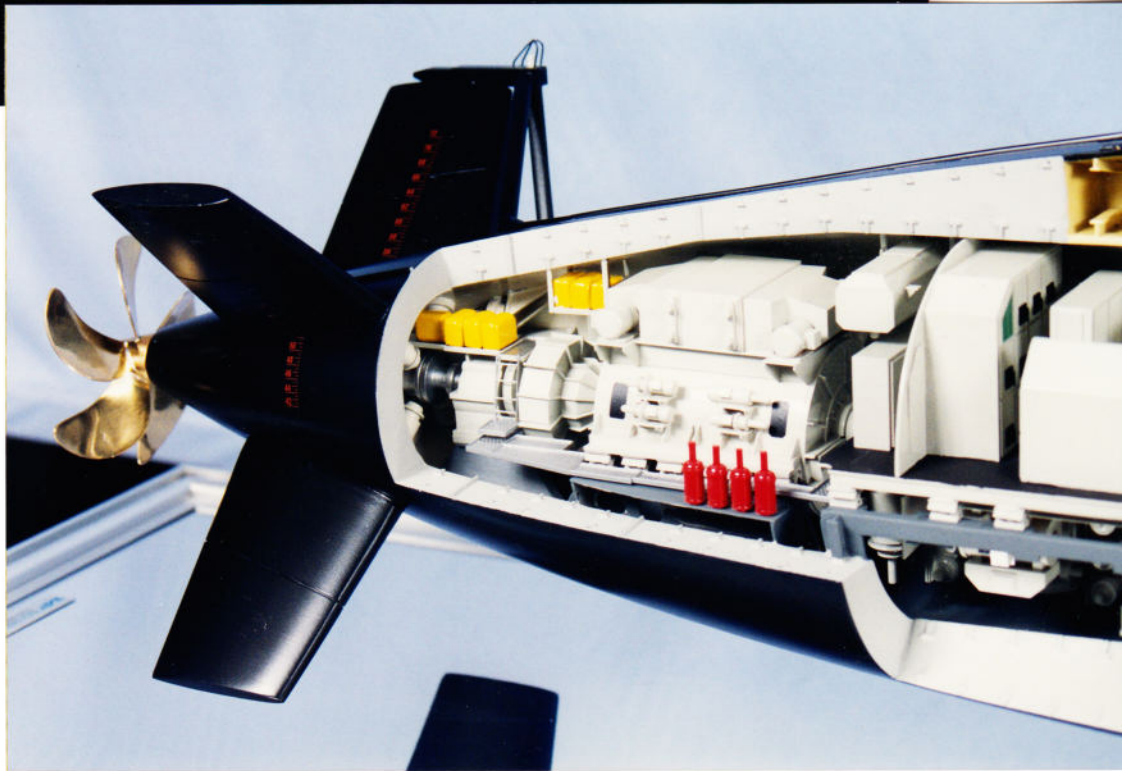
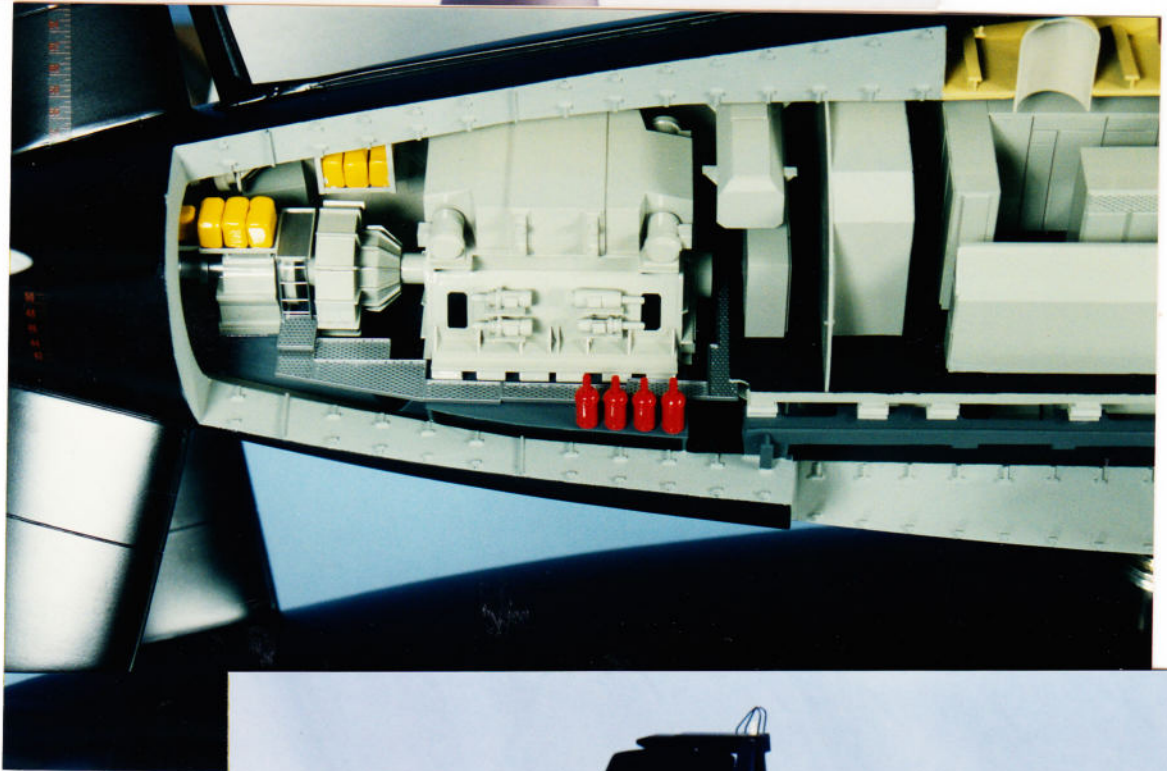
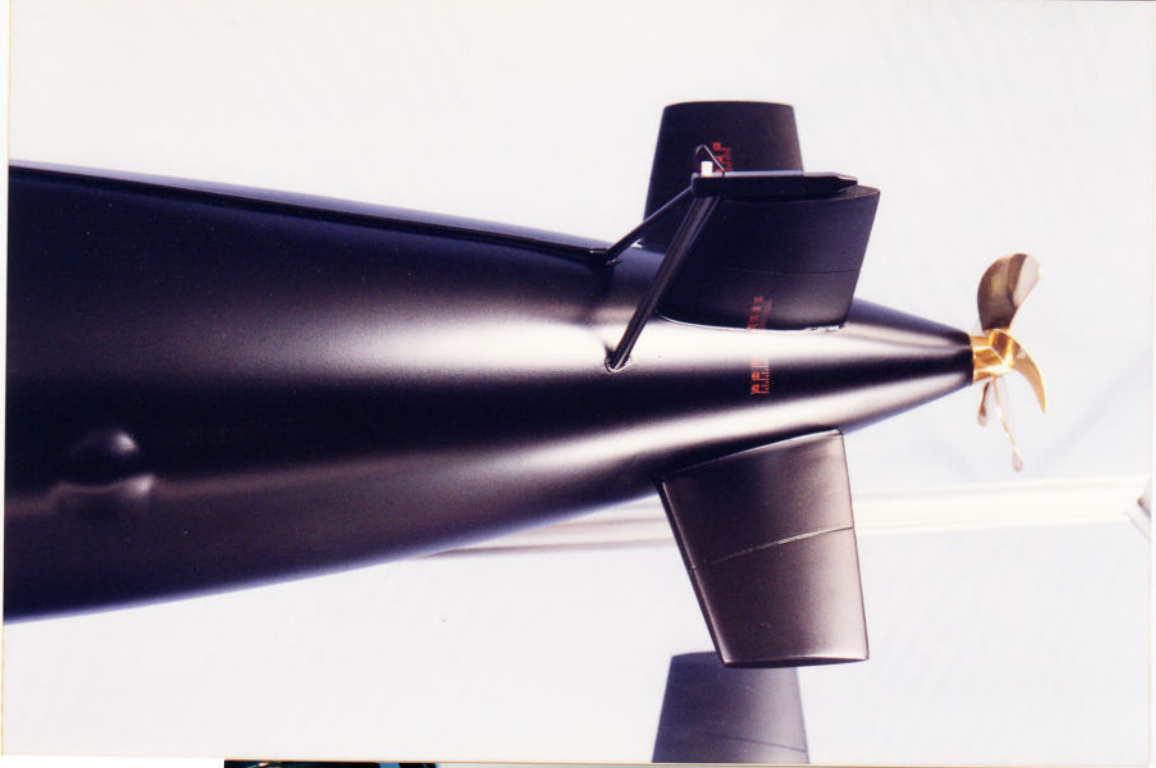

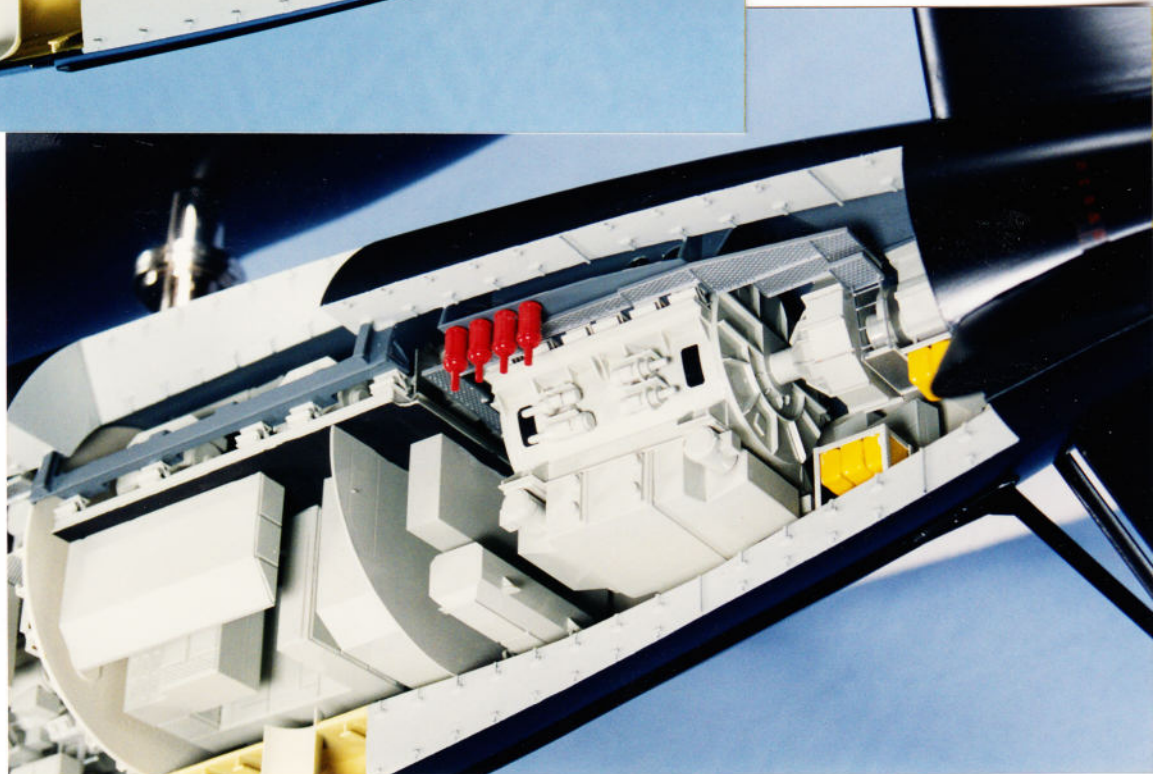
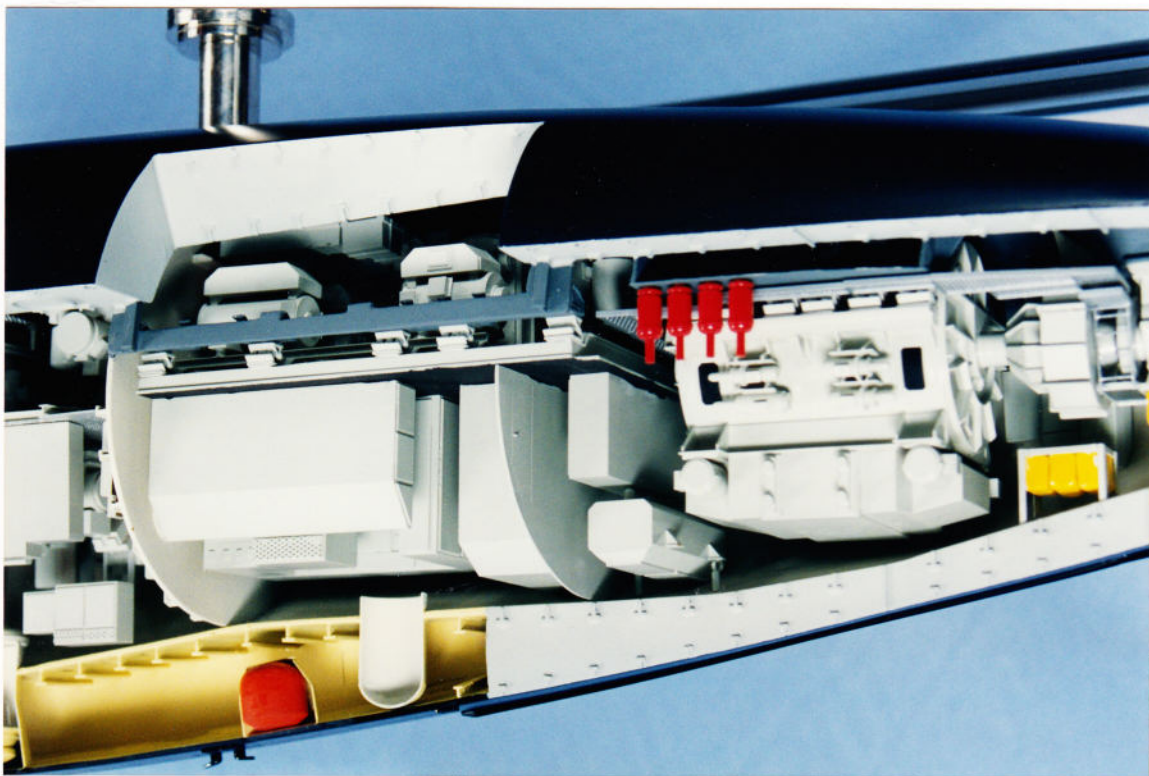
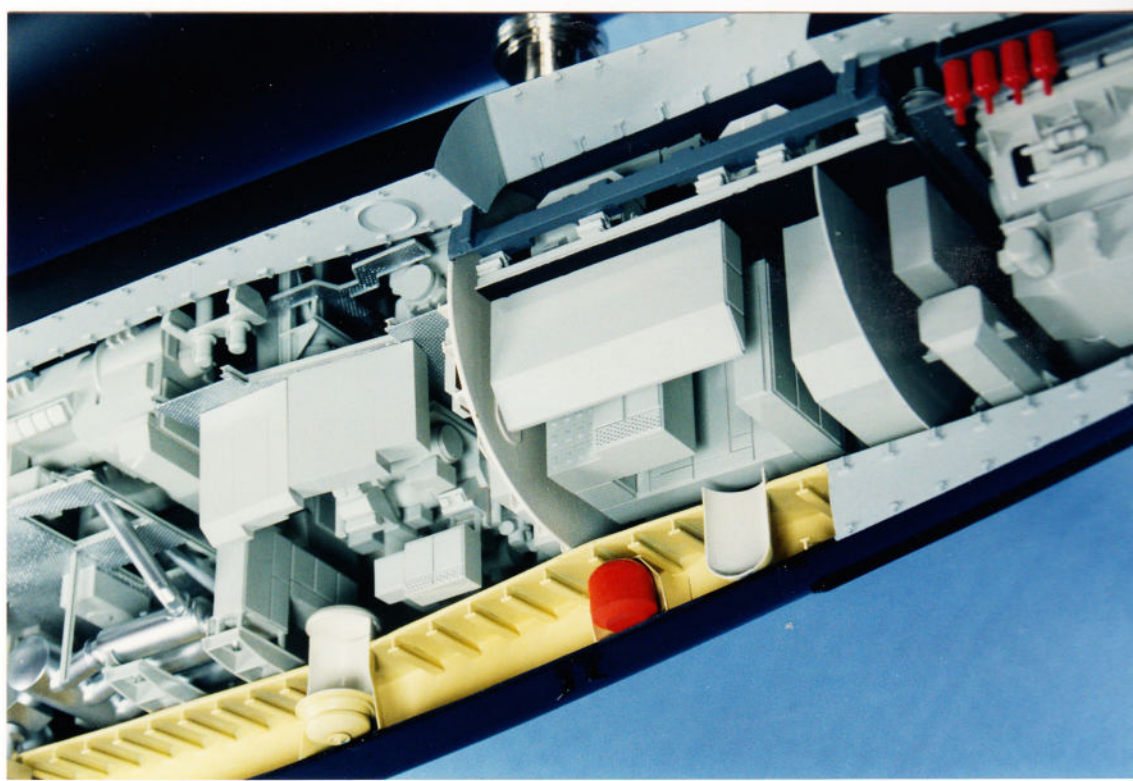

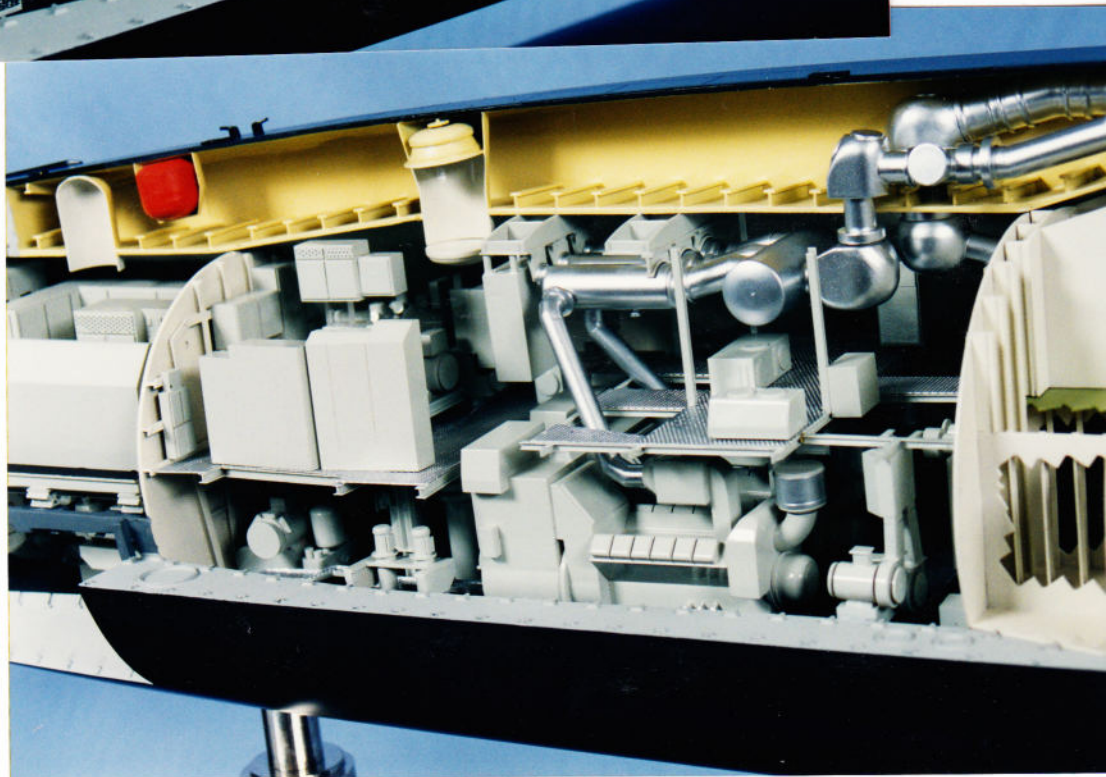
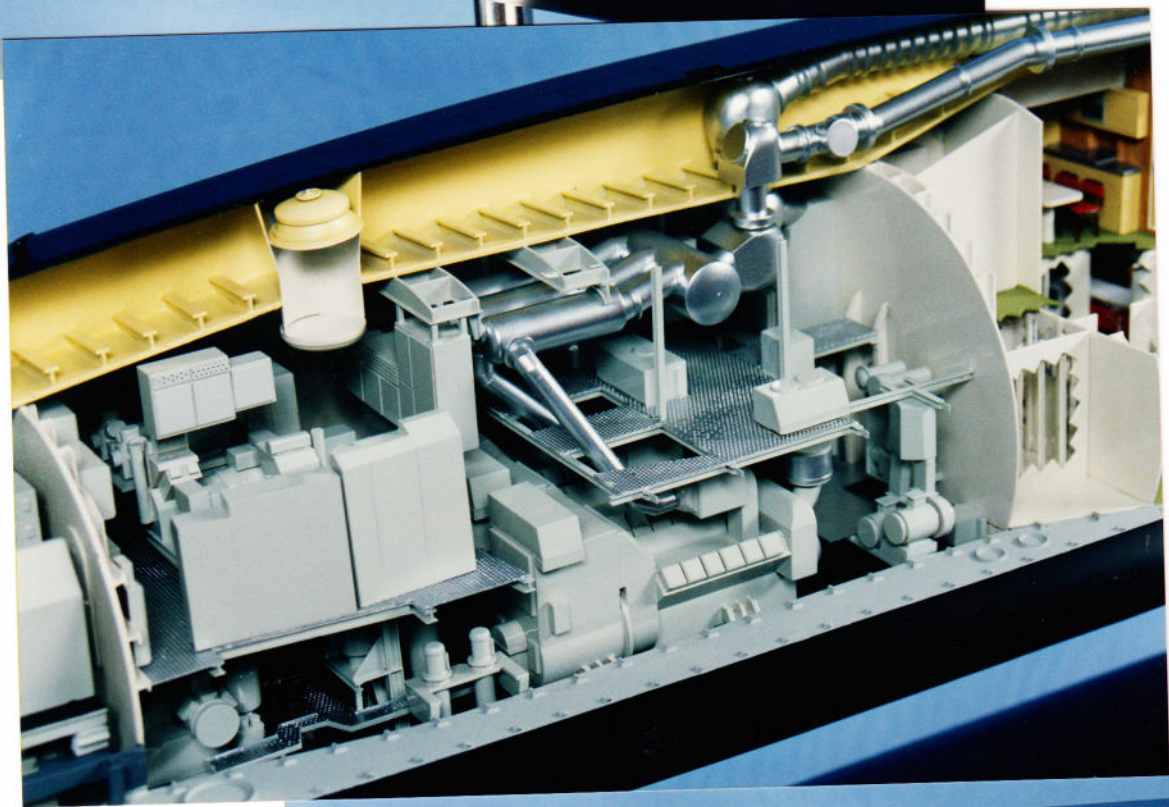
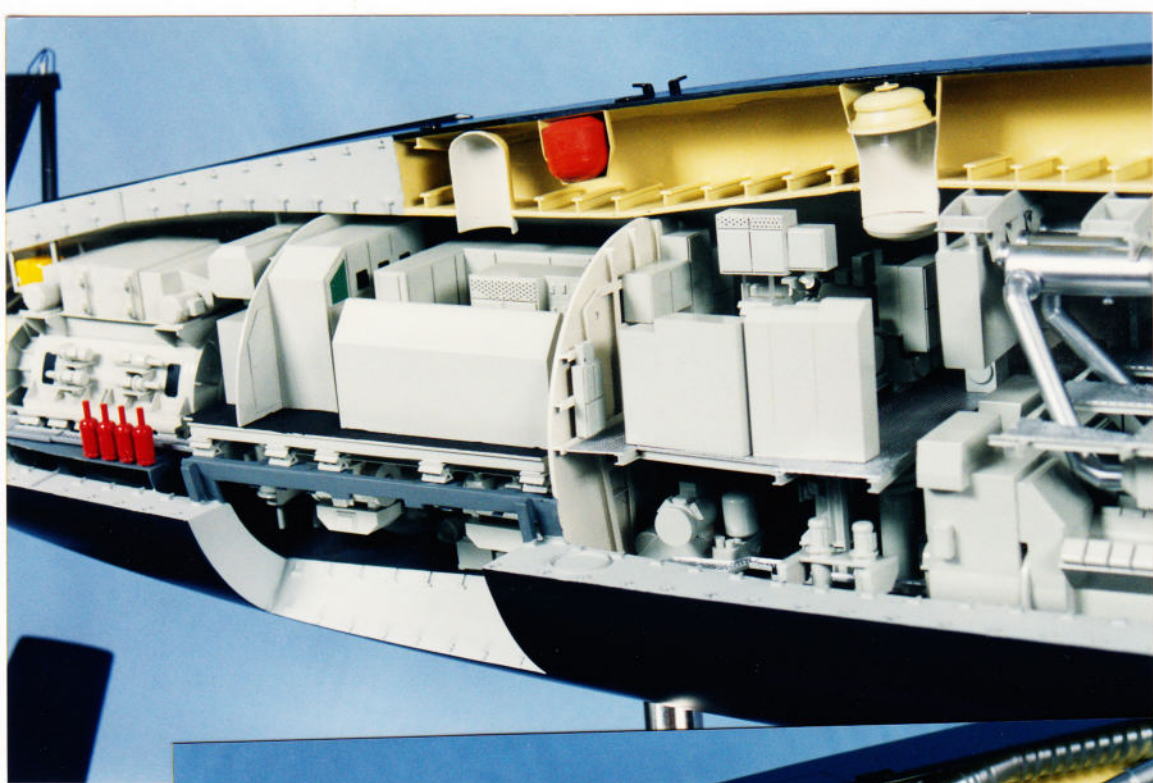

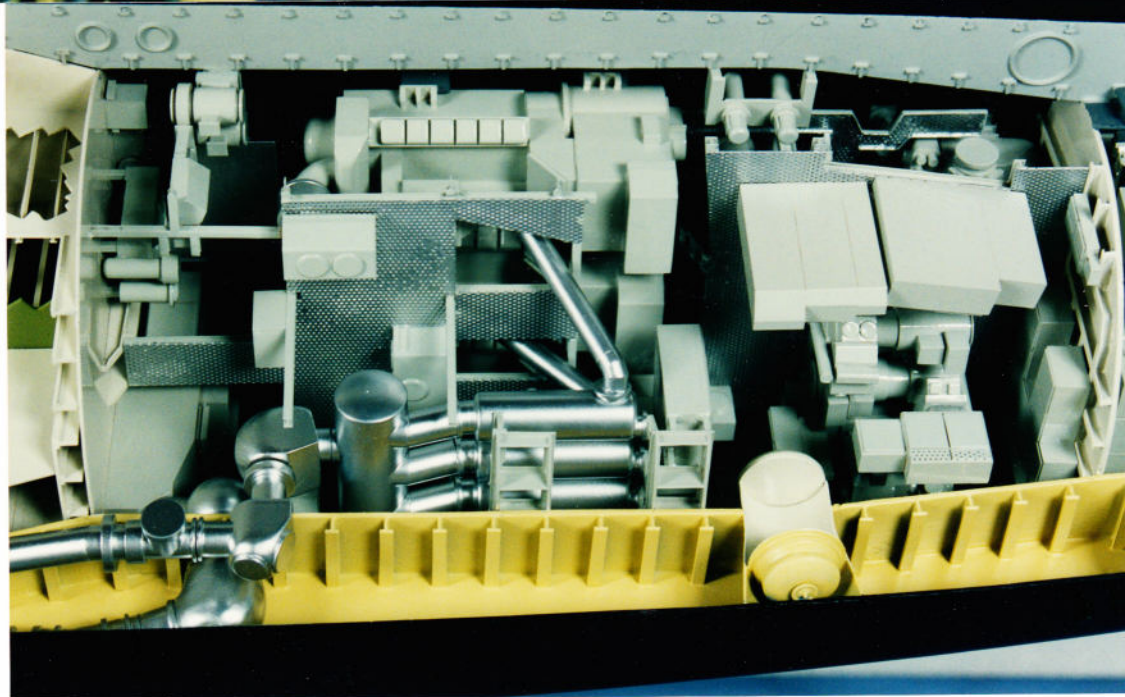
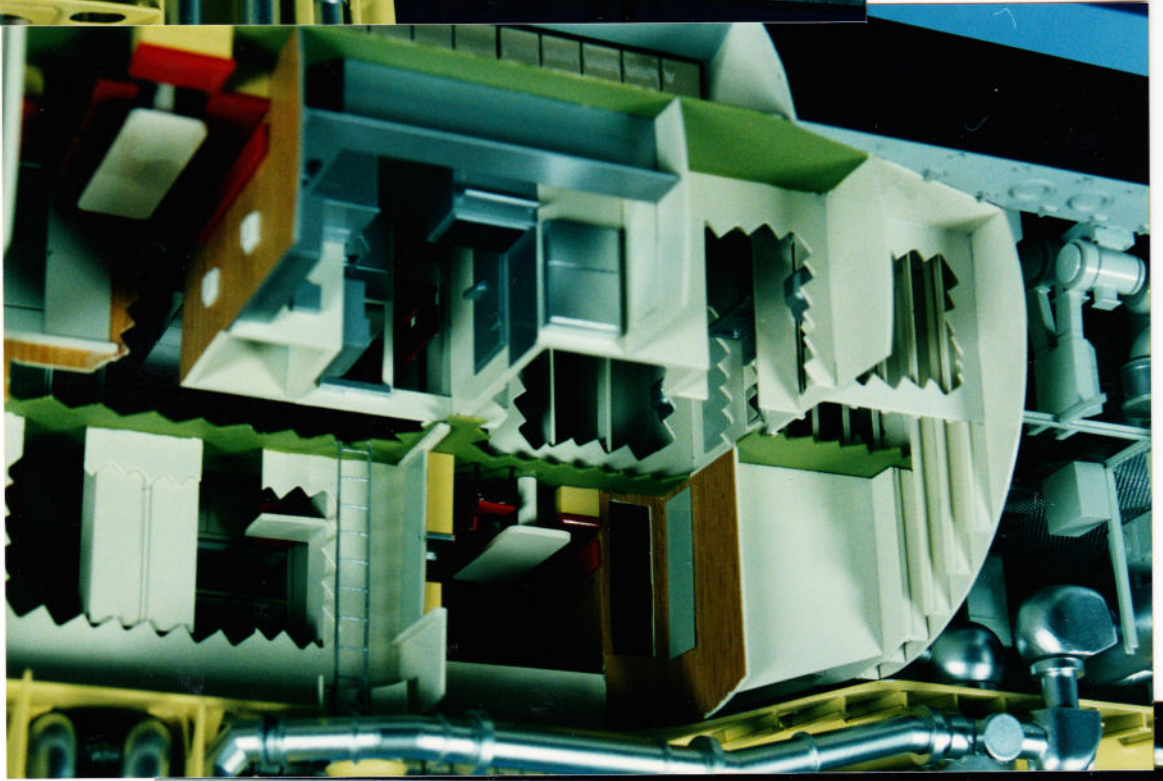
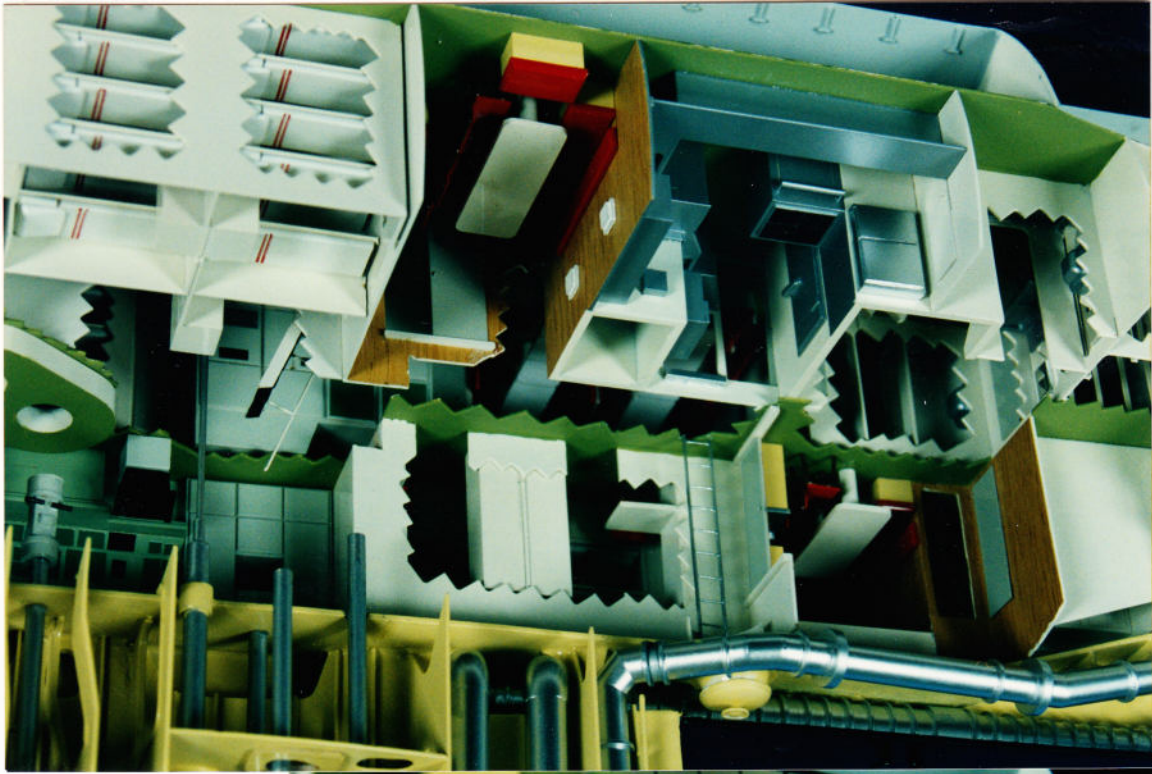

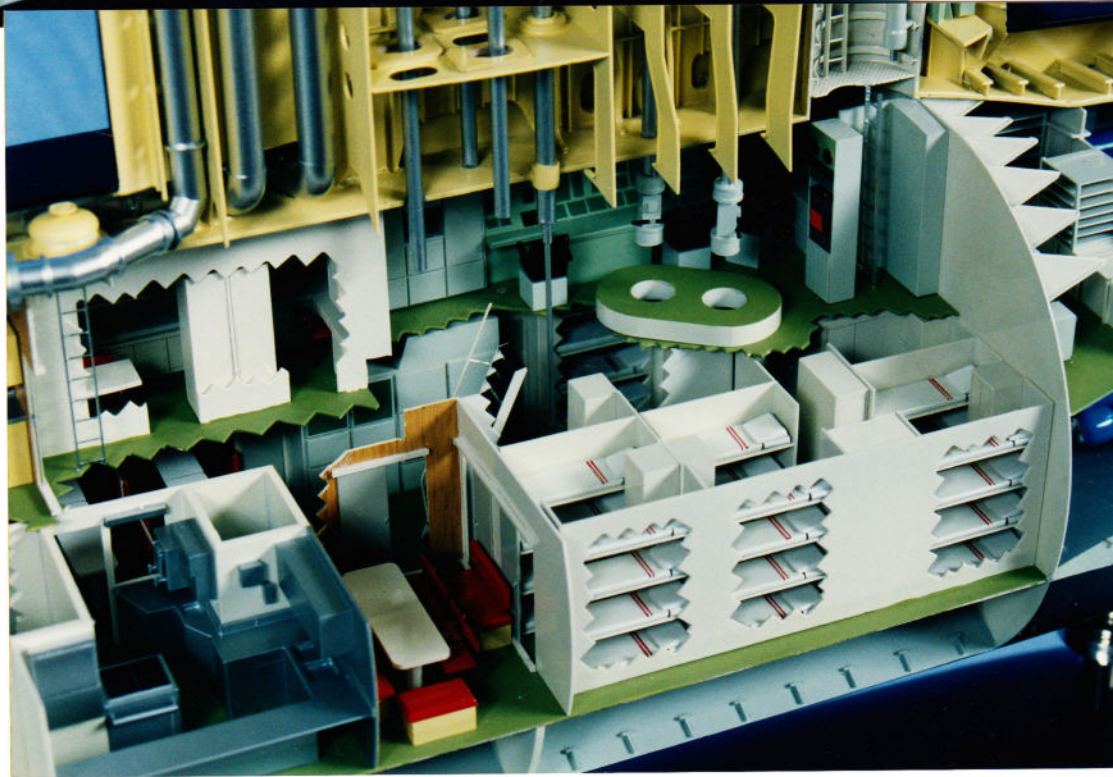
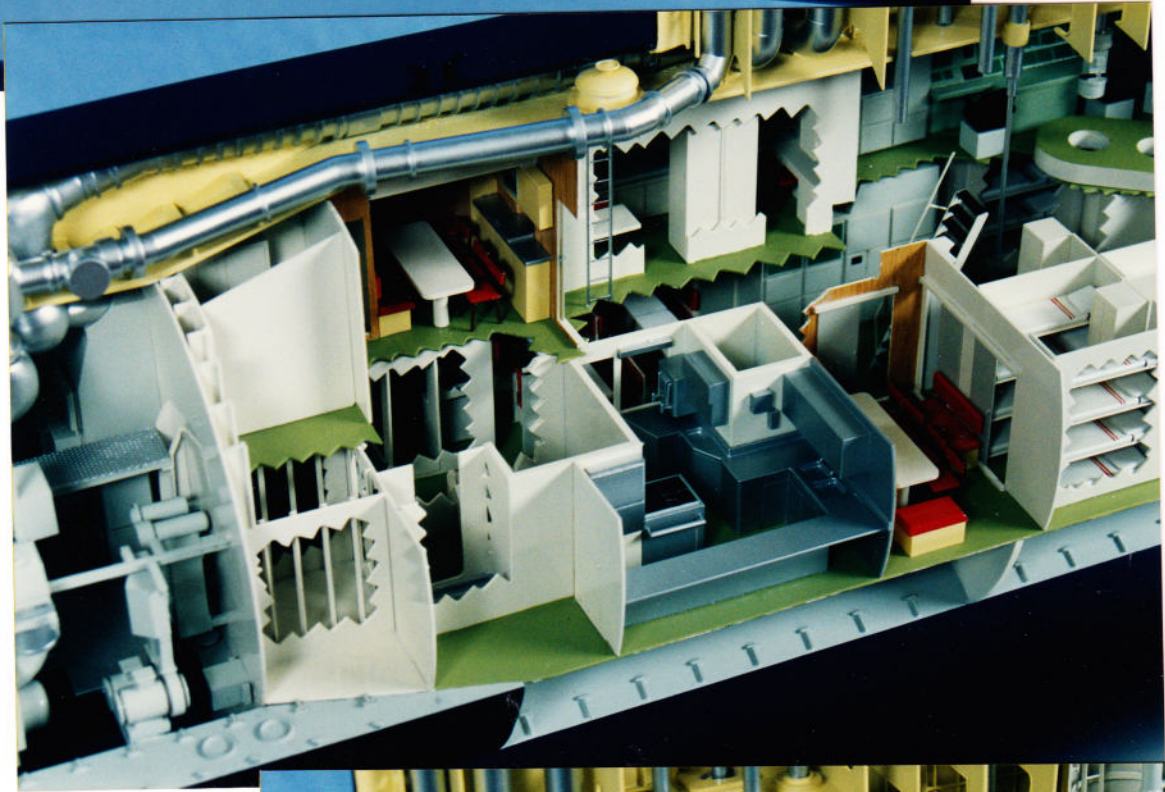
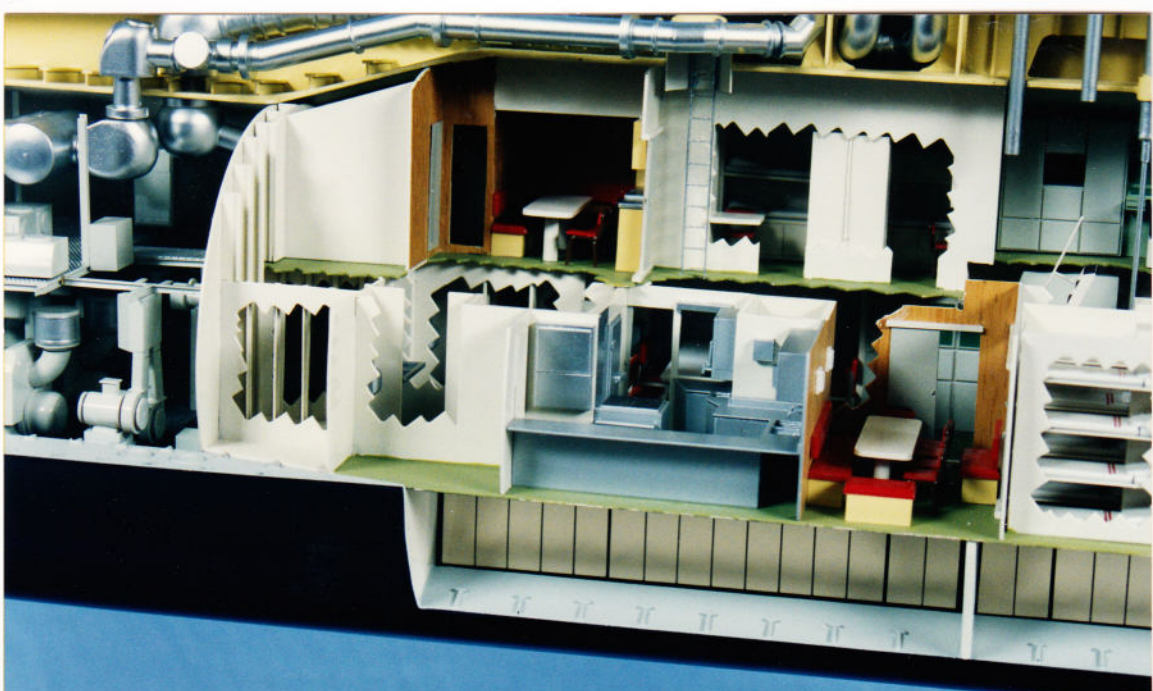

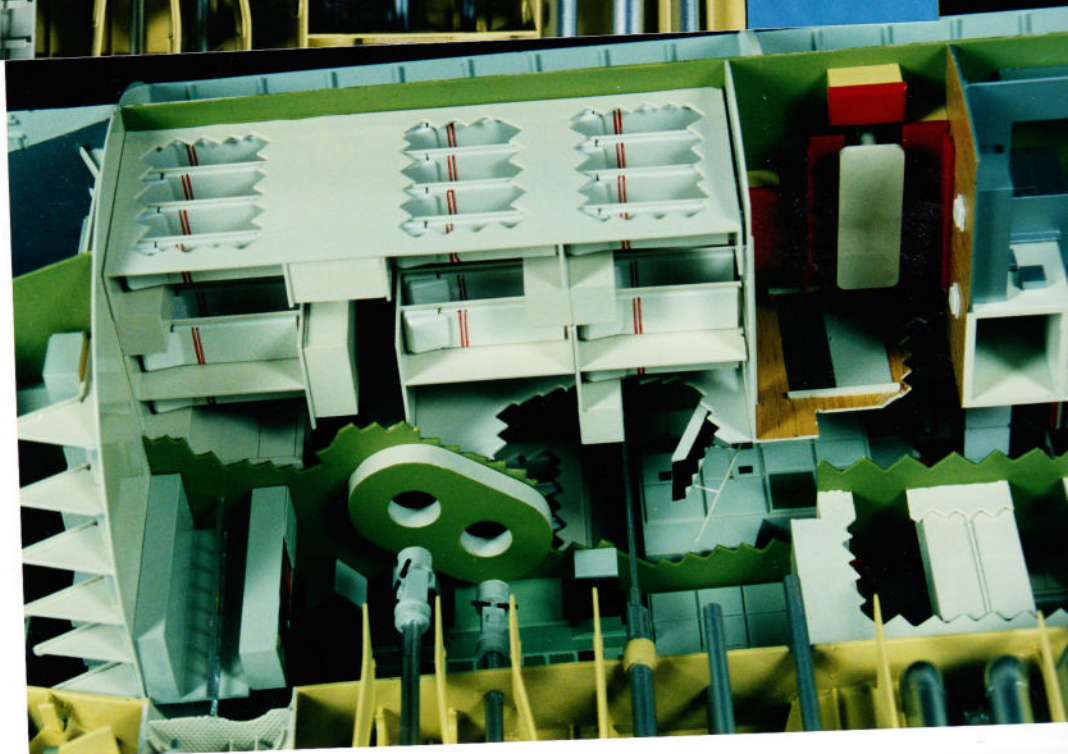
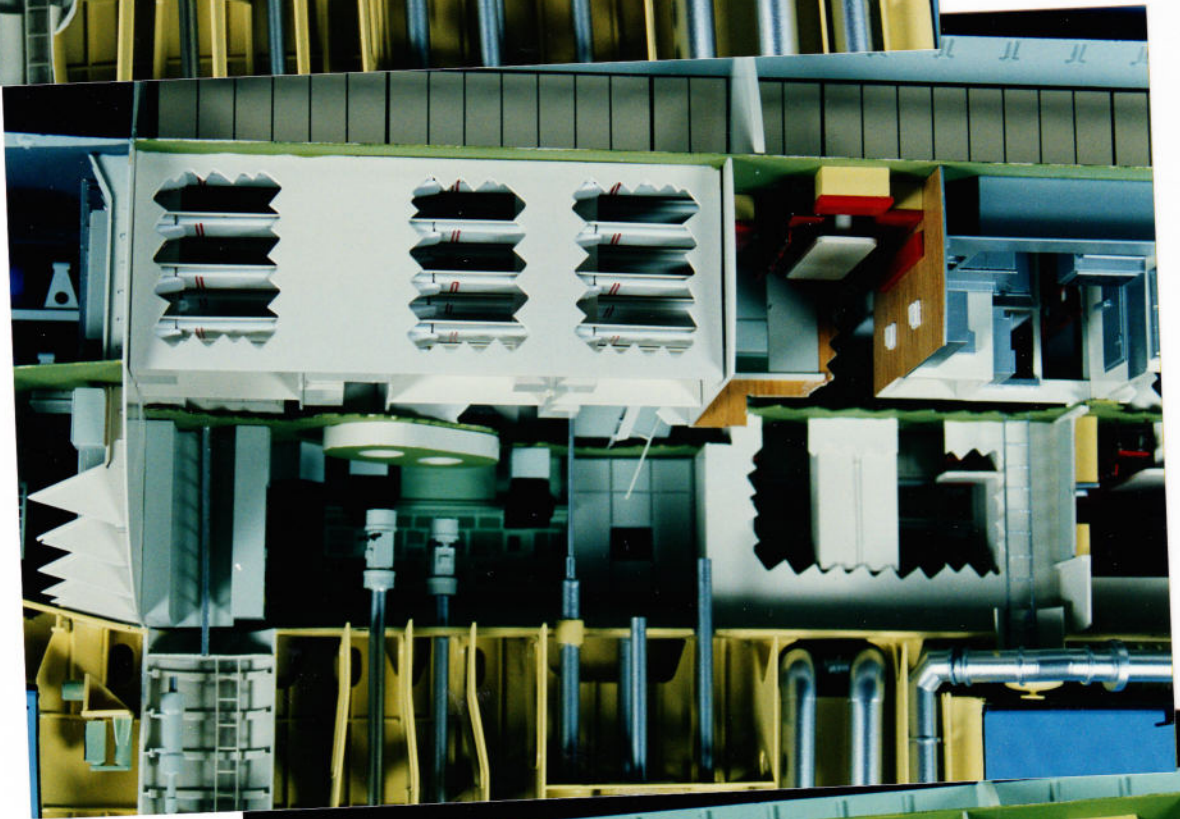

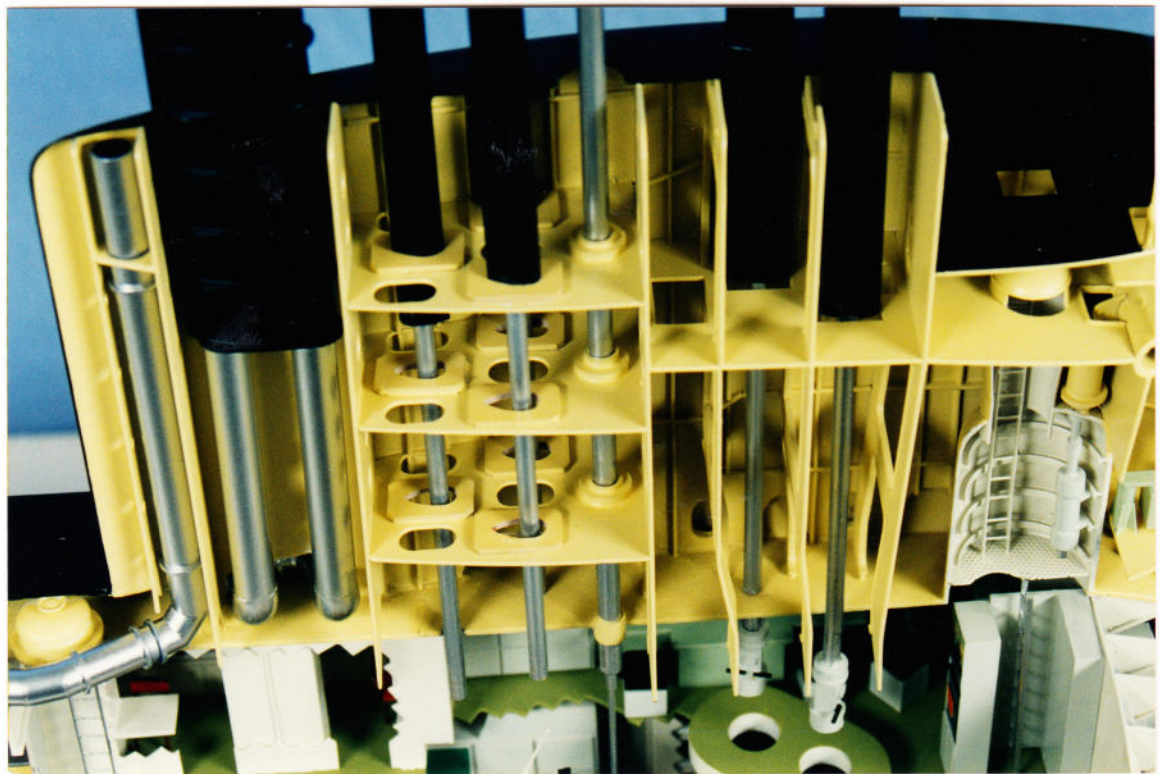
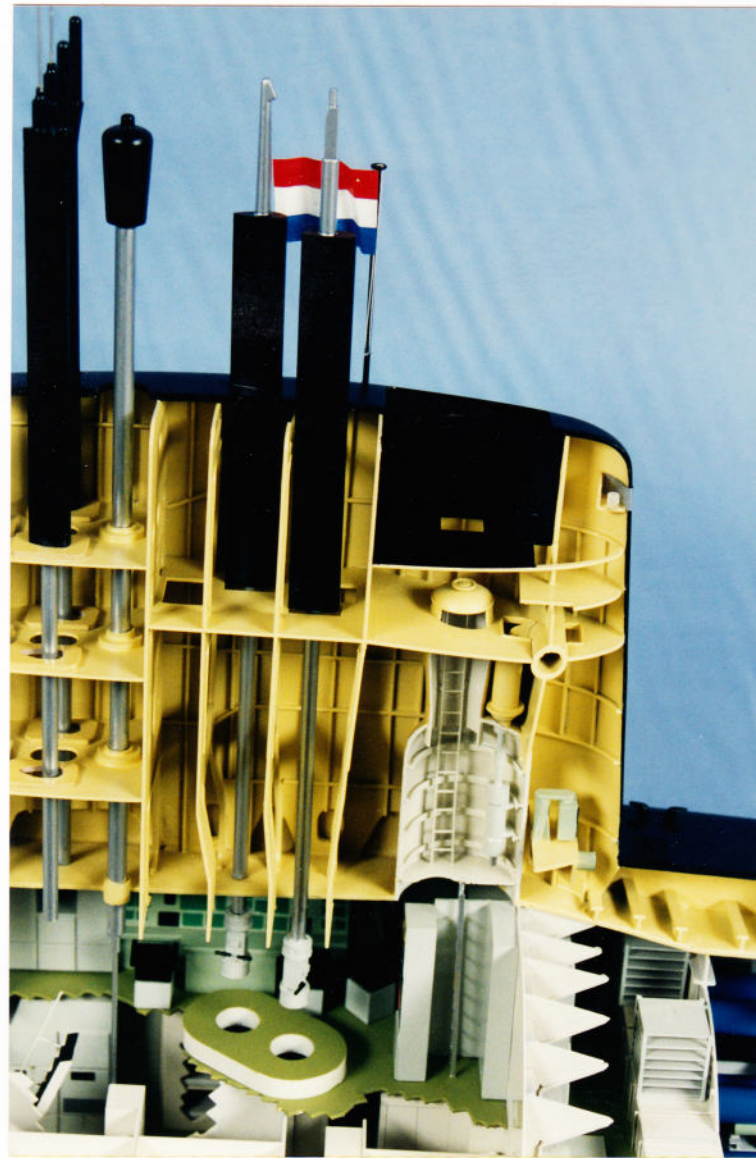
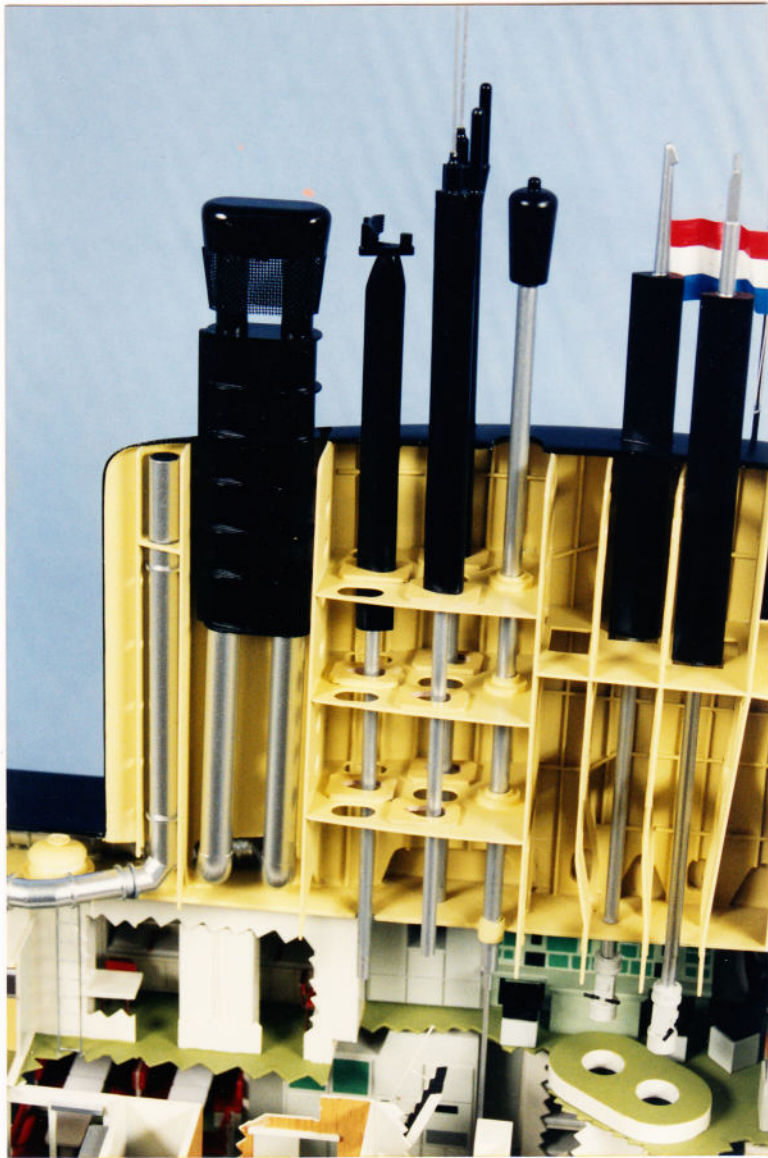

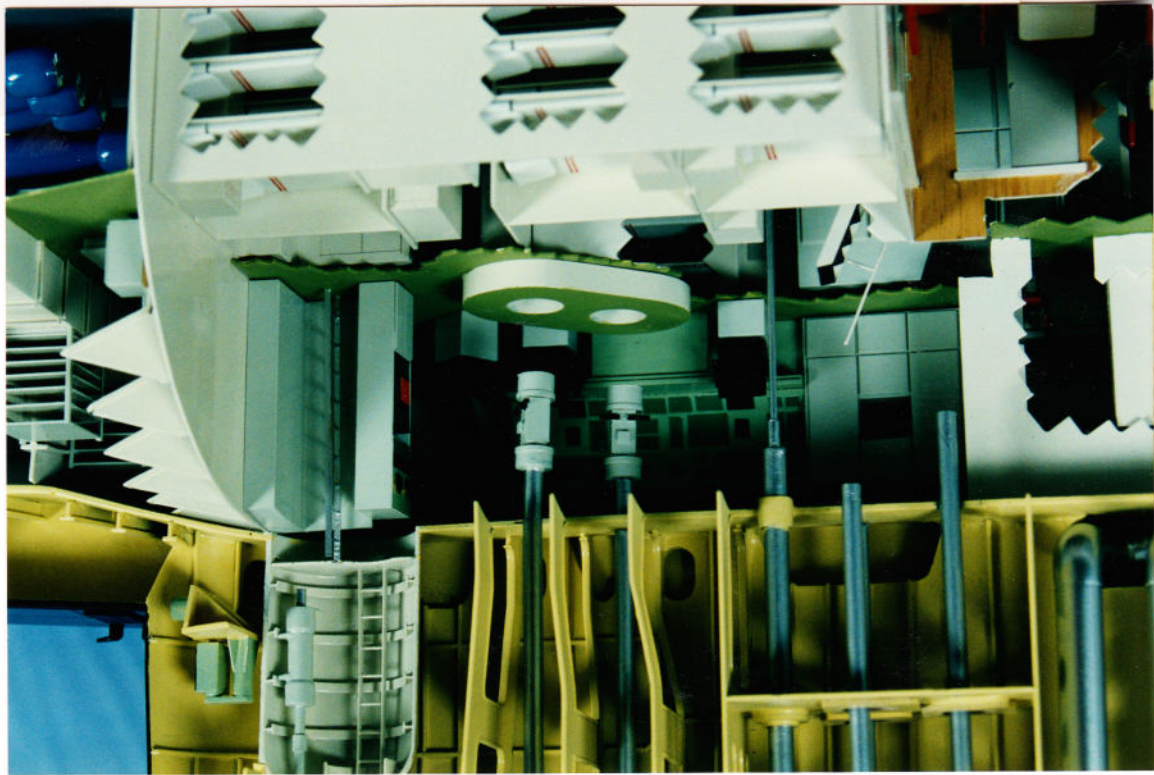
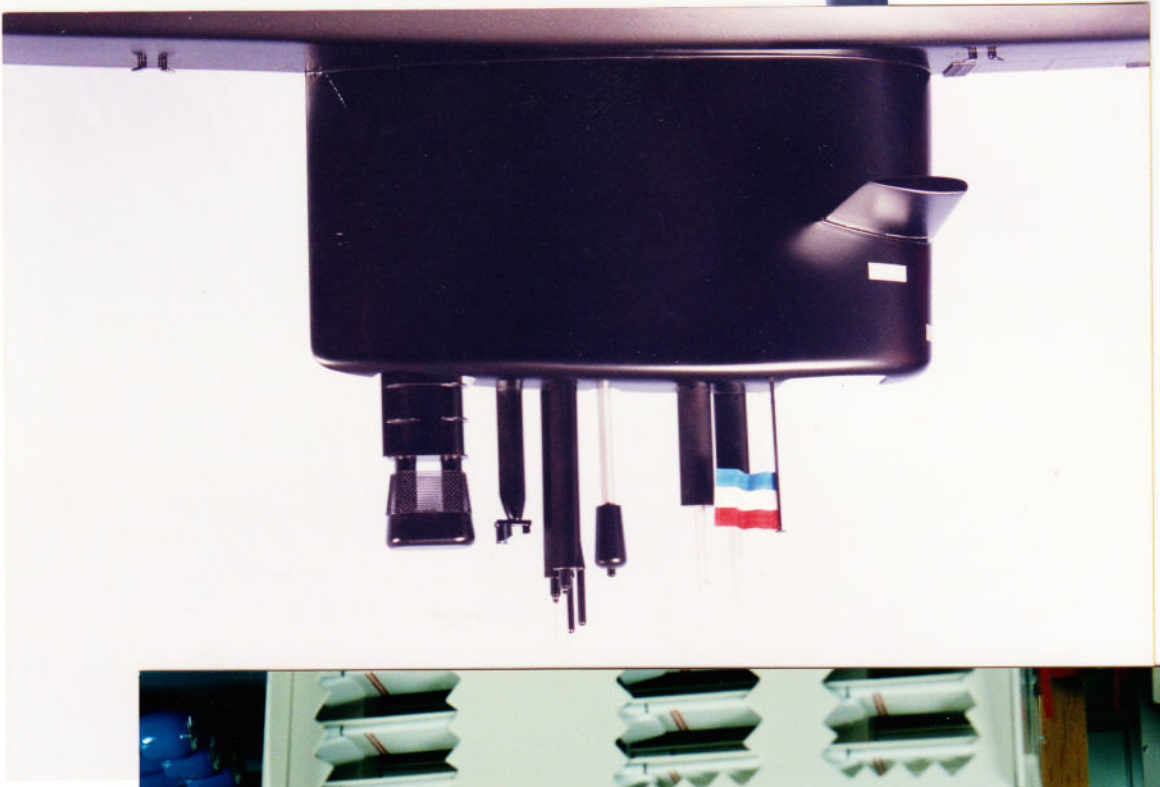
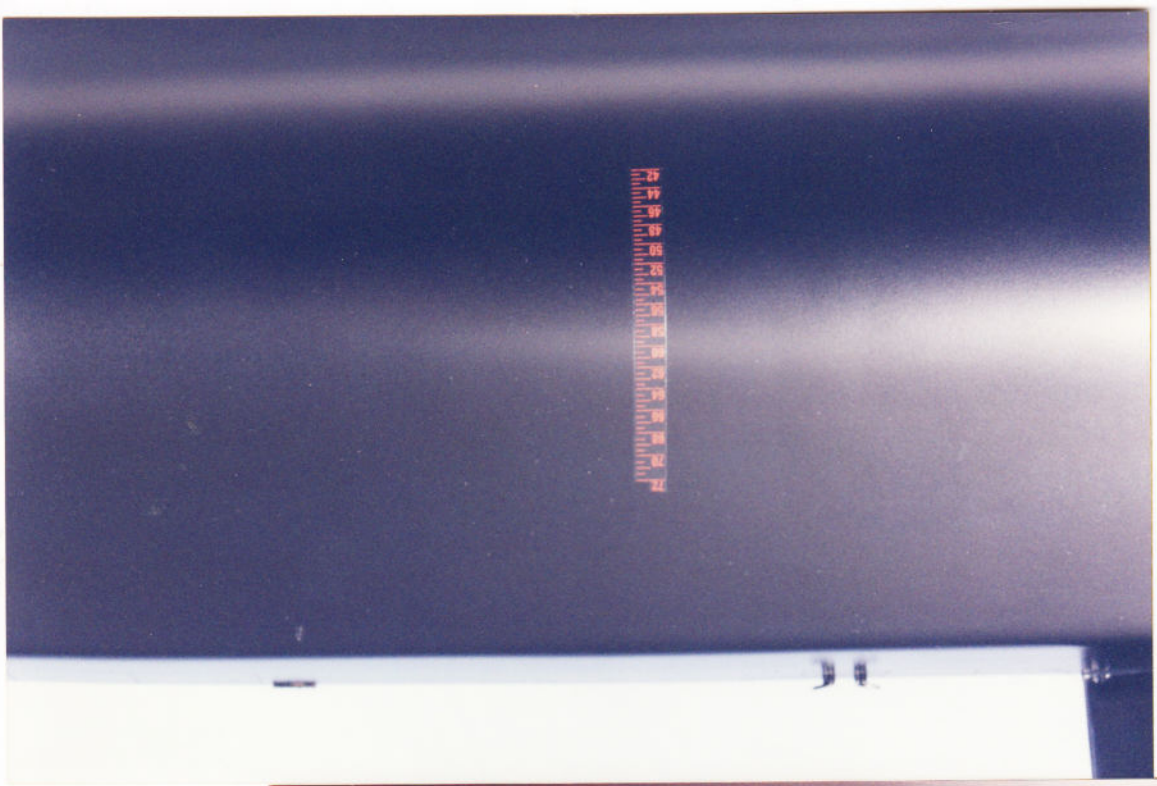

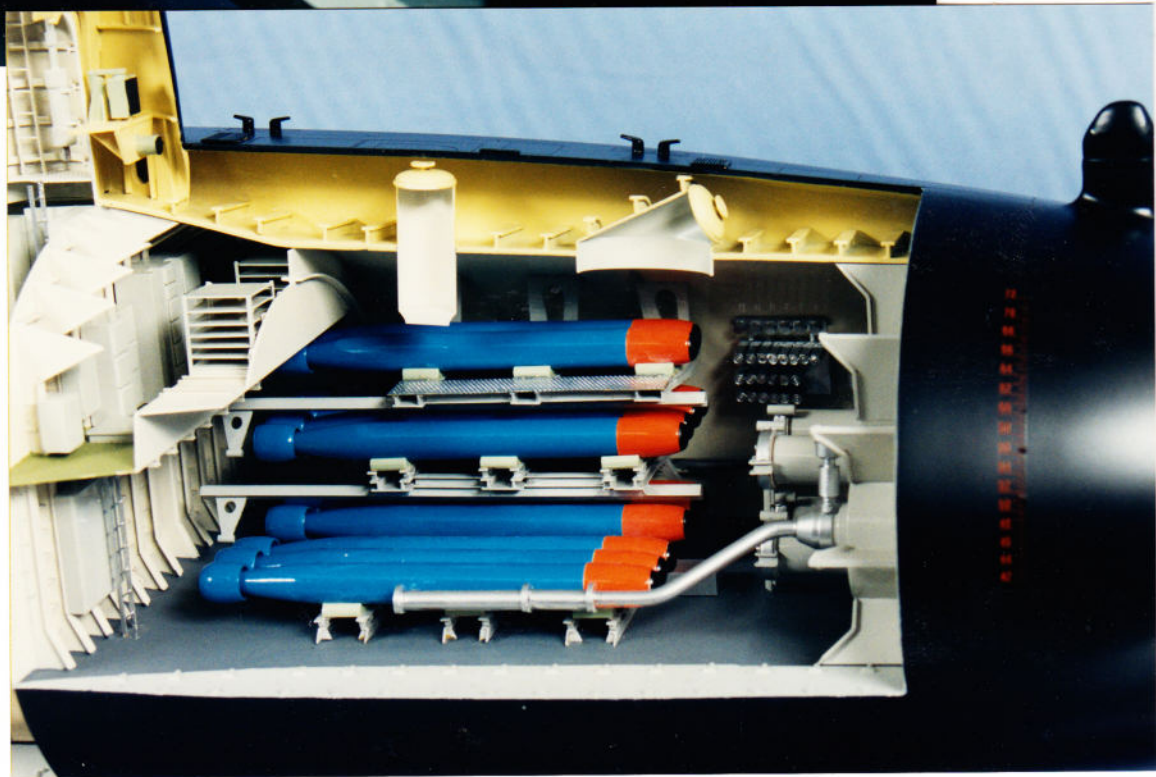
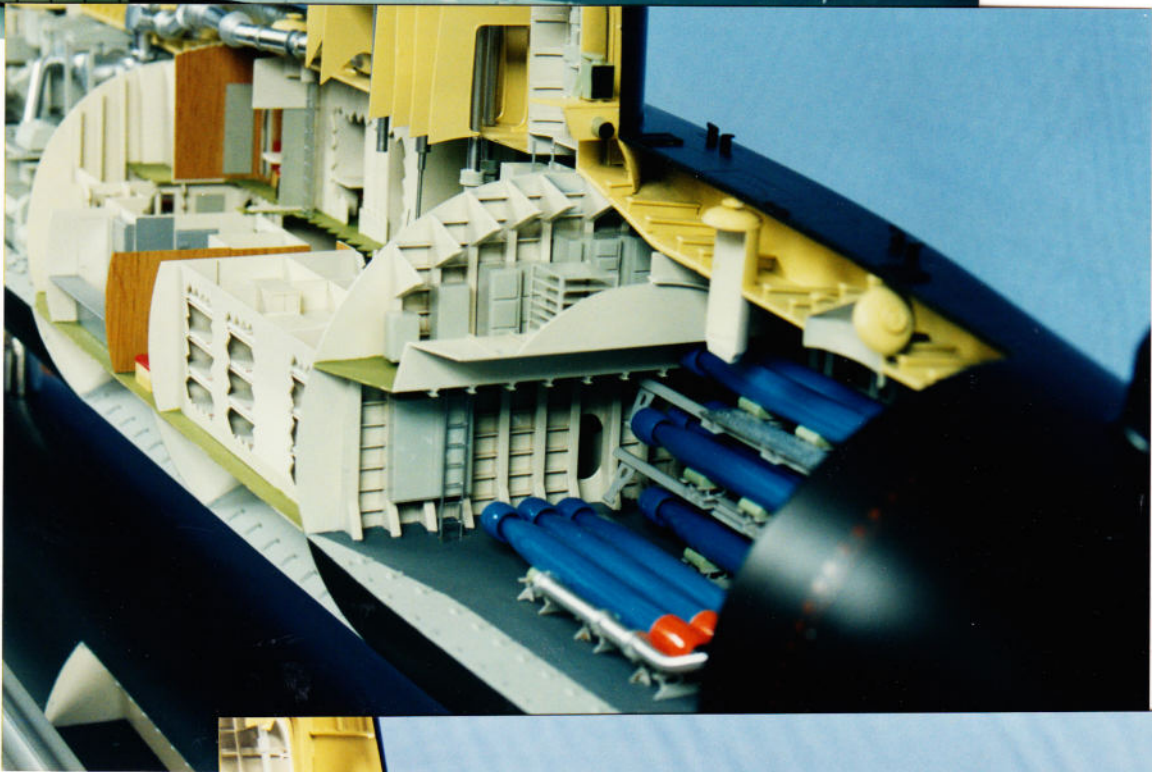
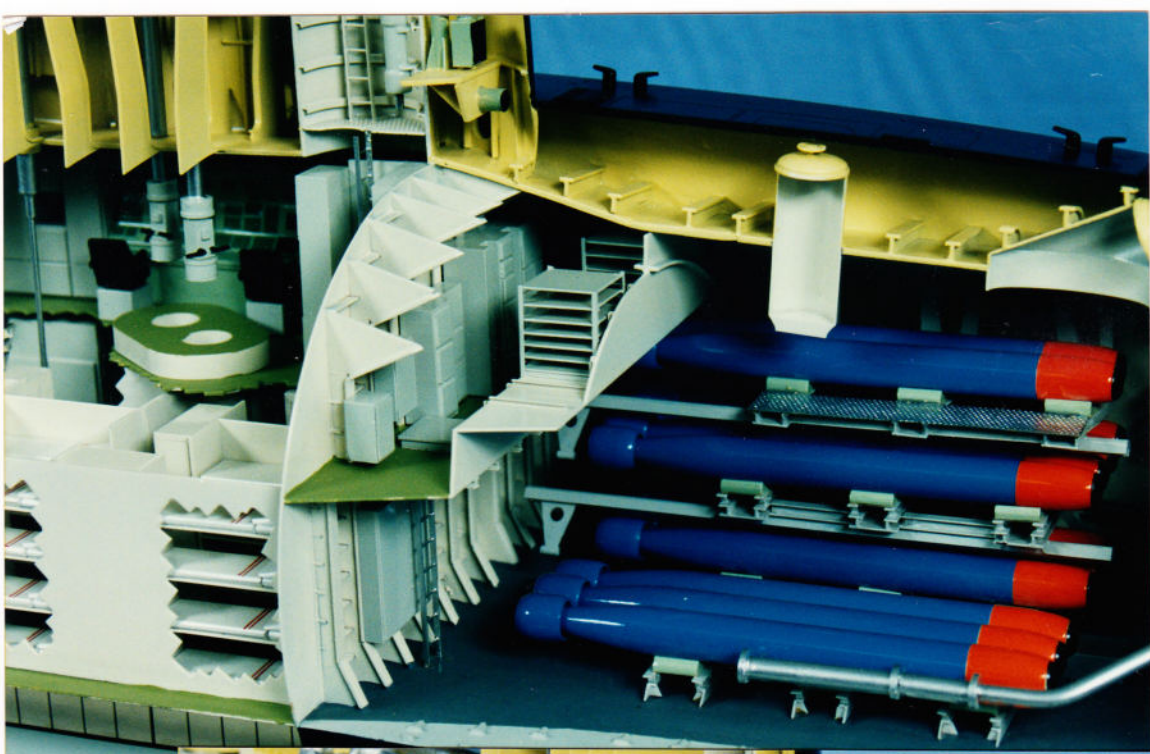

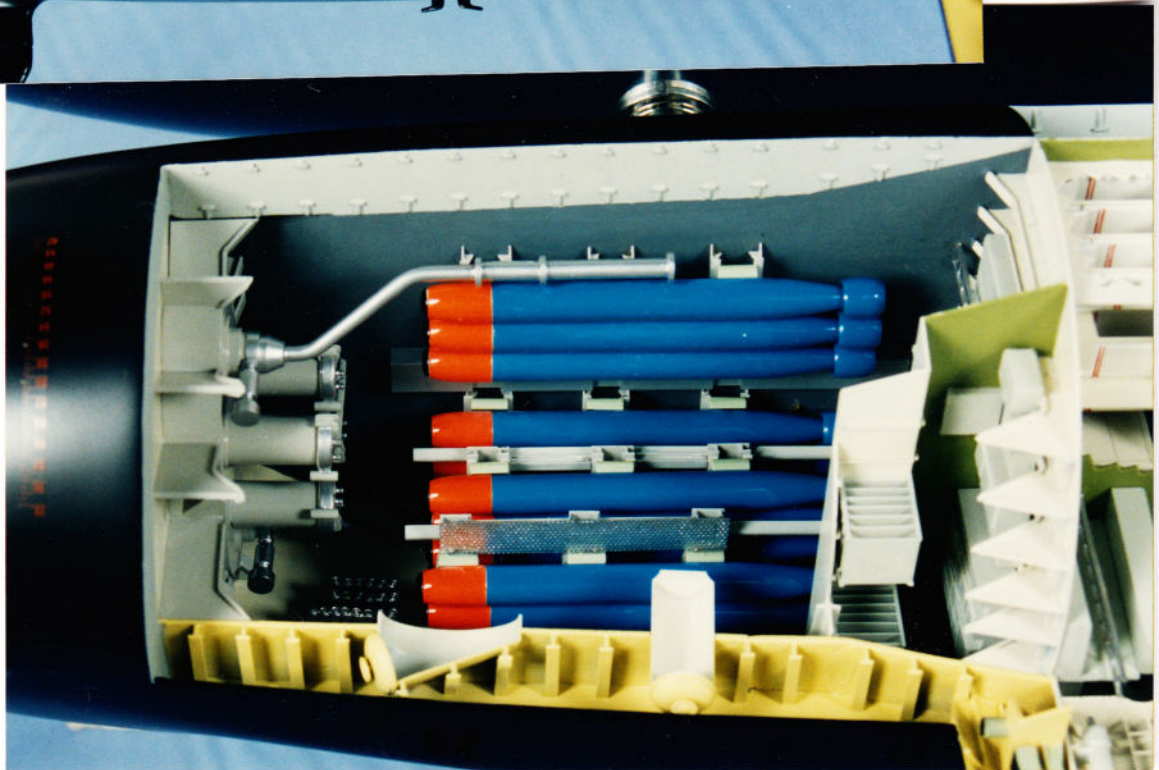
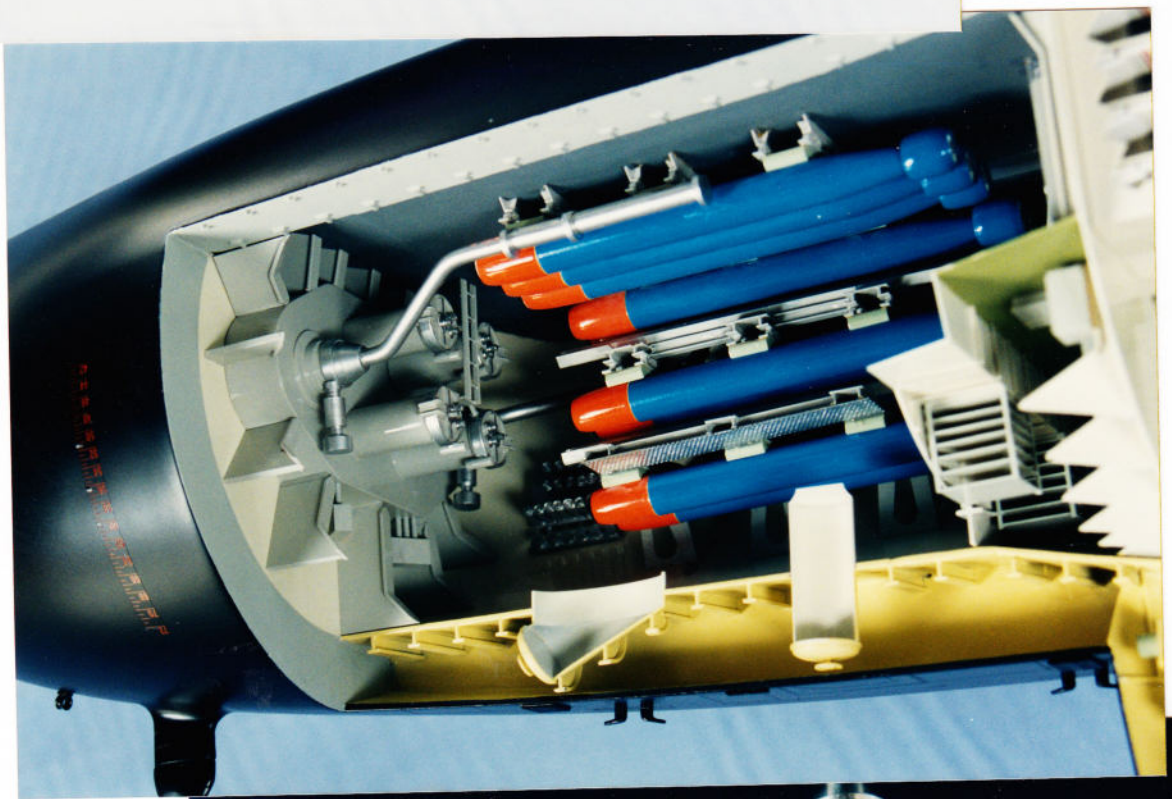



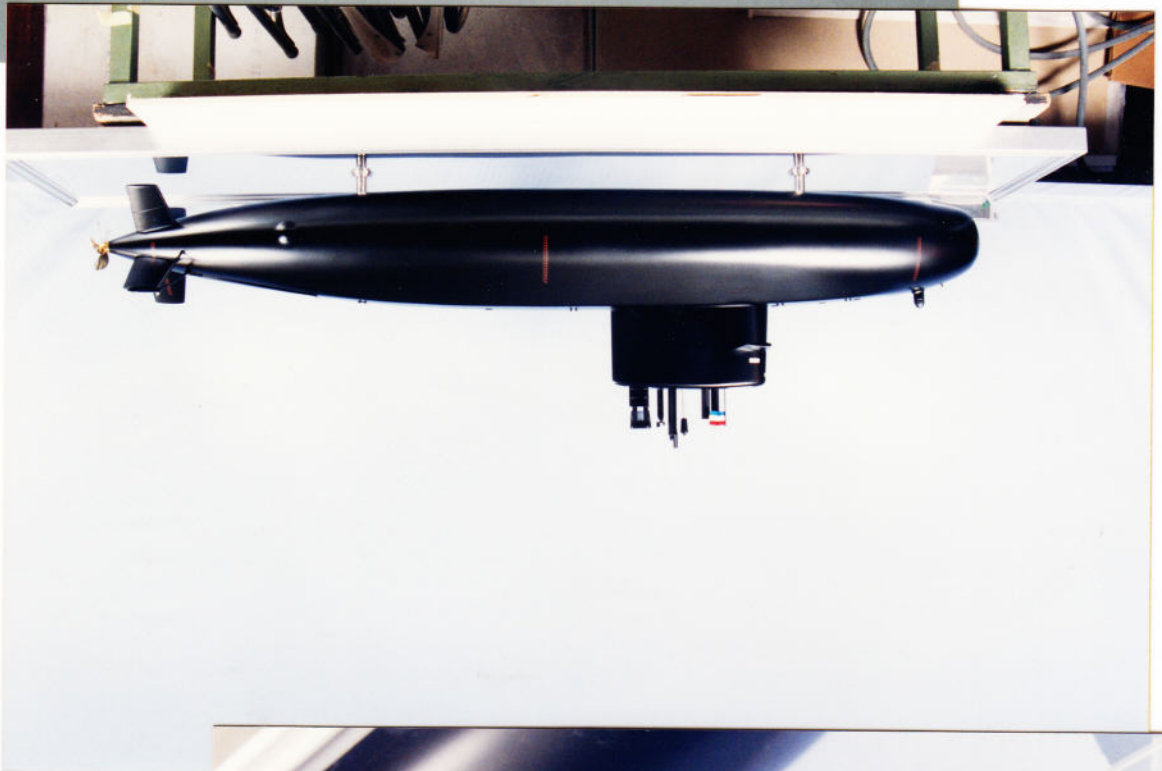
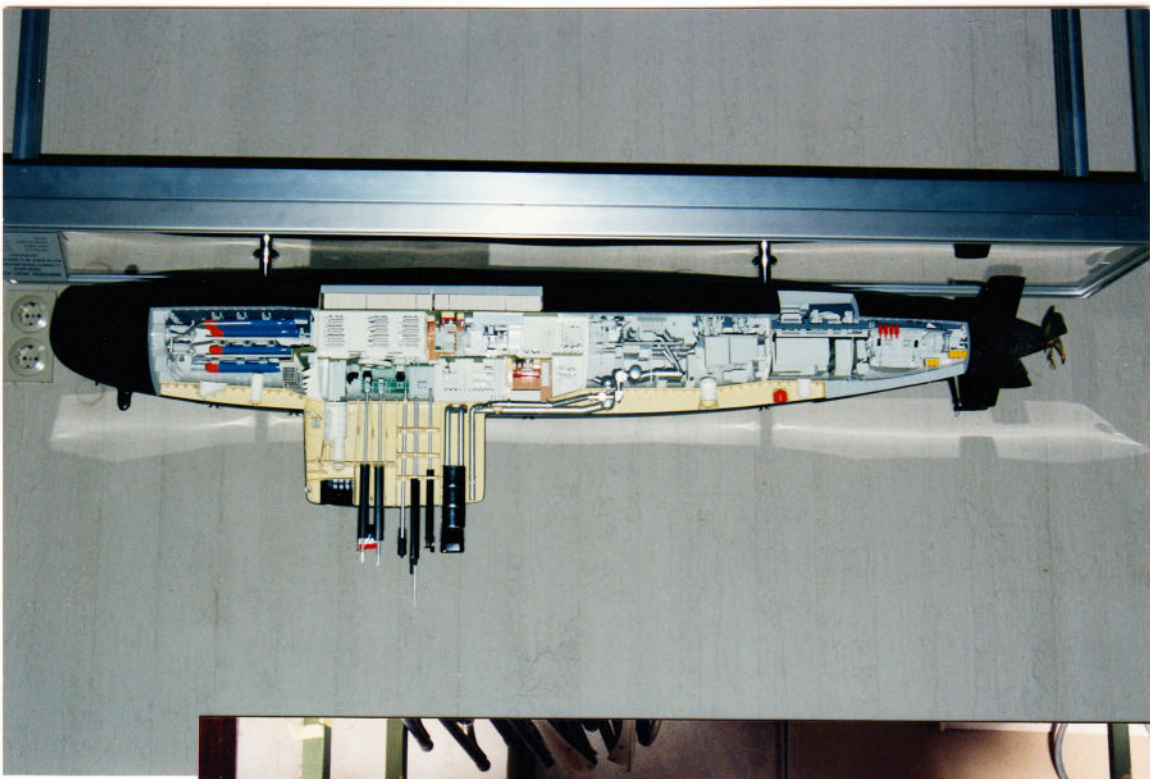

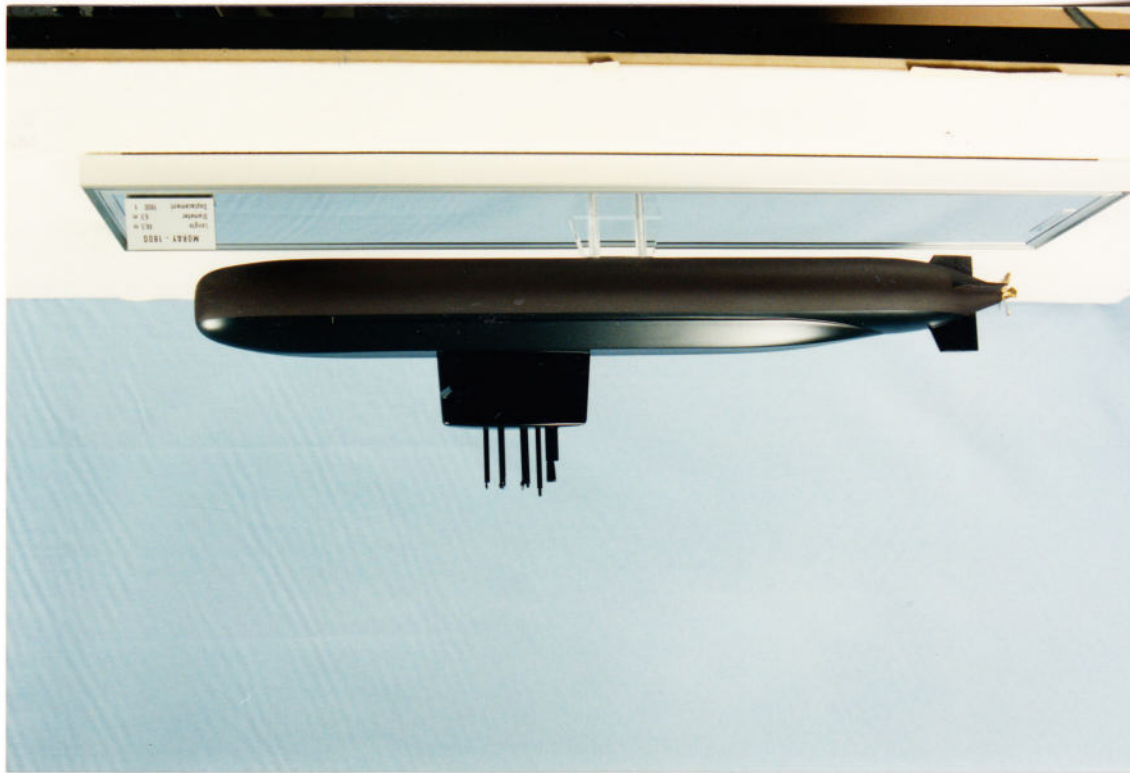

RDM
 1:100
 S modelen
 MORAY 1800
 19/1/93
 1/2 uen.

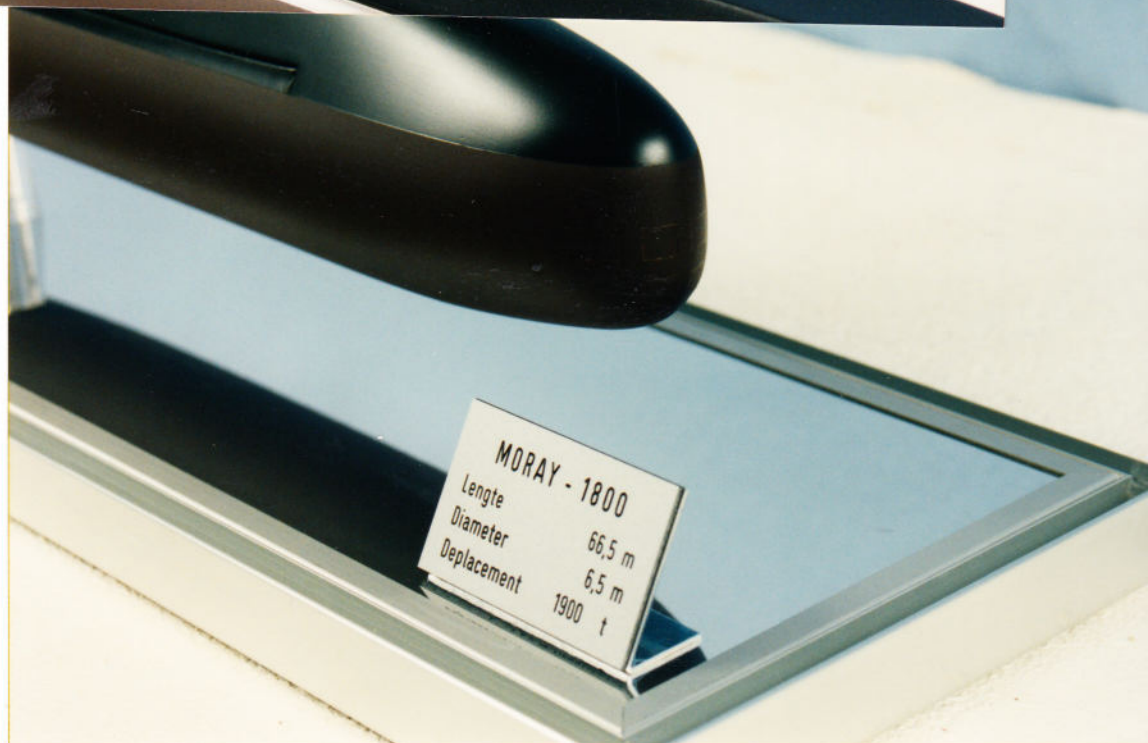
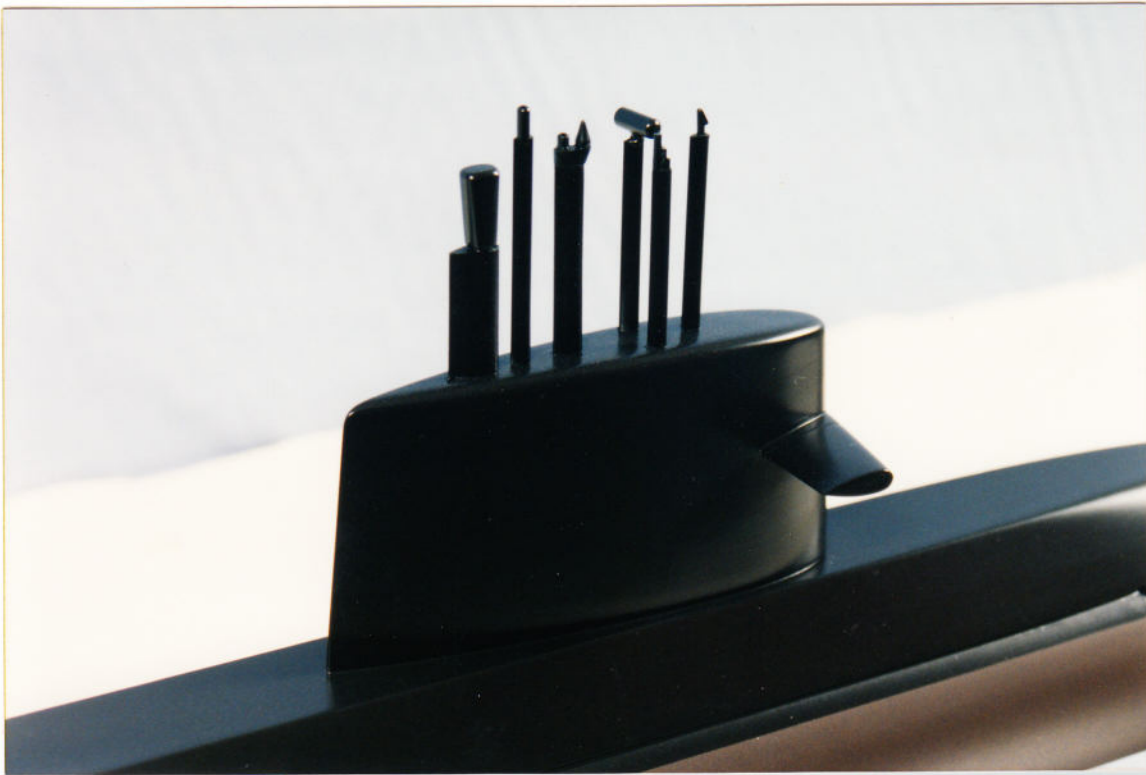

MORAY - 1800	
Length	66,5 m
Diameter	6,5 m
Displacement	1900 t

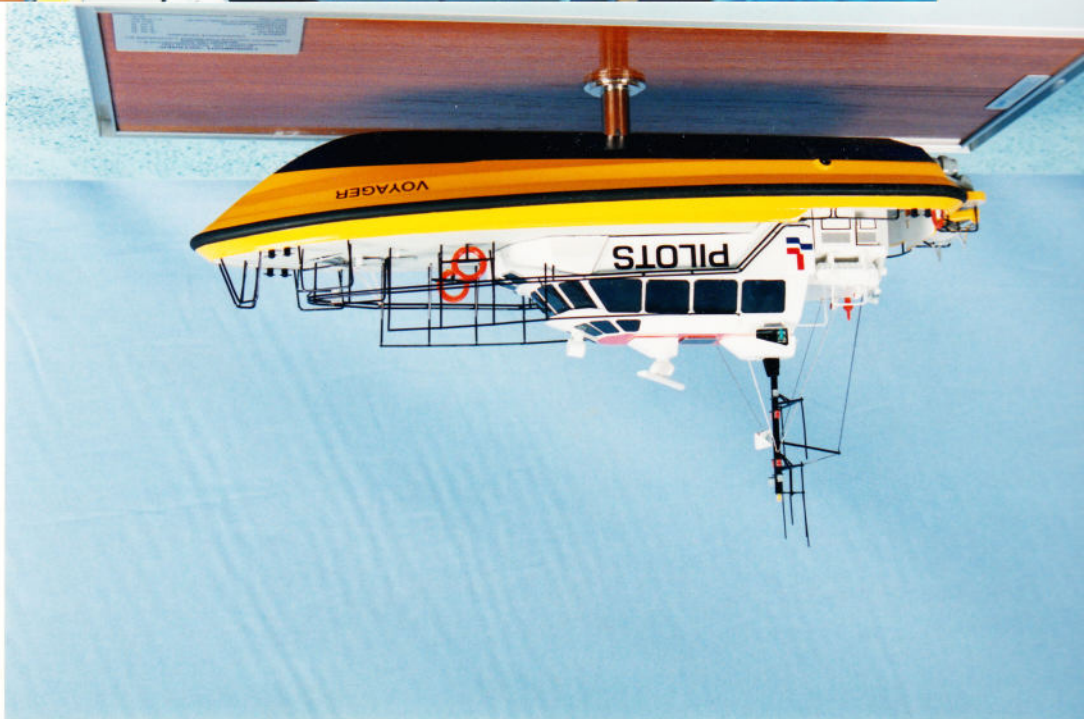

"VOYAGER"
 ENGELER BV
 LOODSBOOT
 1:50
 23-9-94
 147 mm



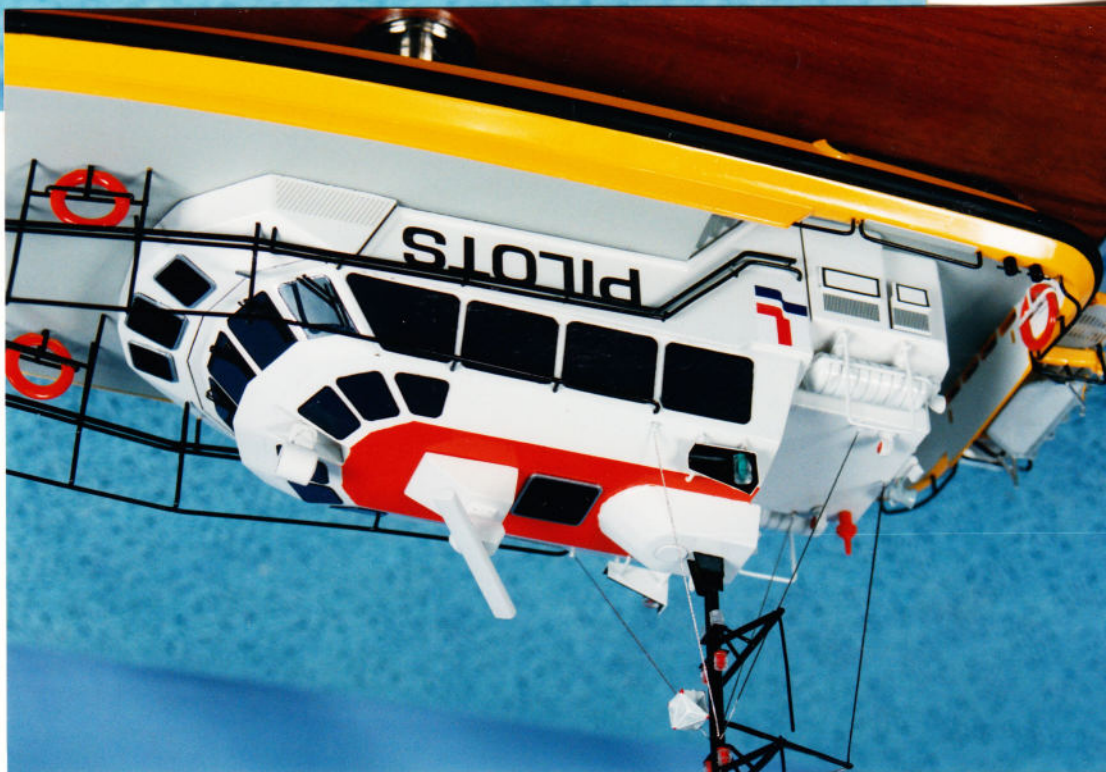
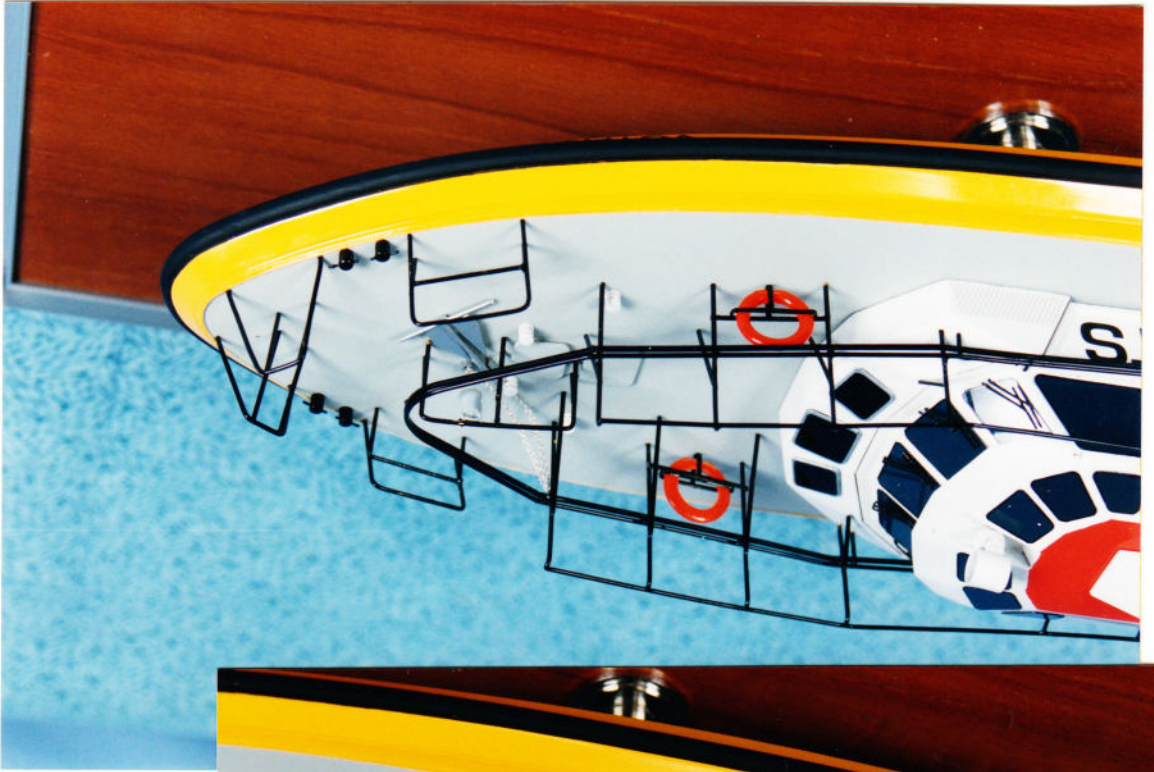
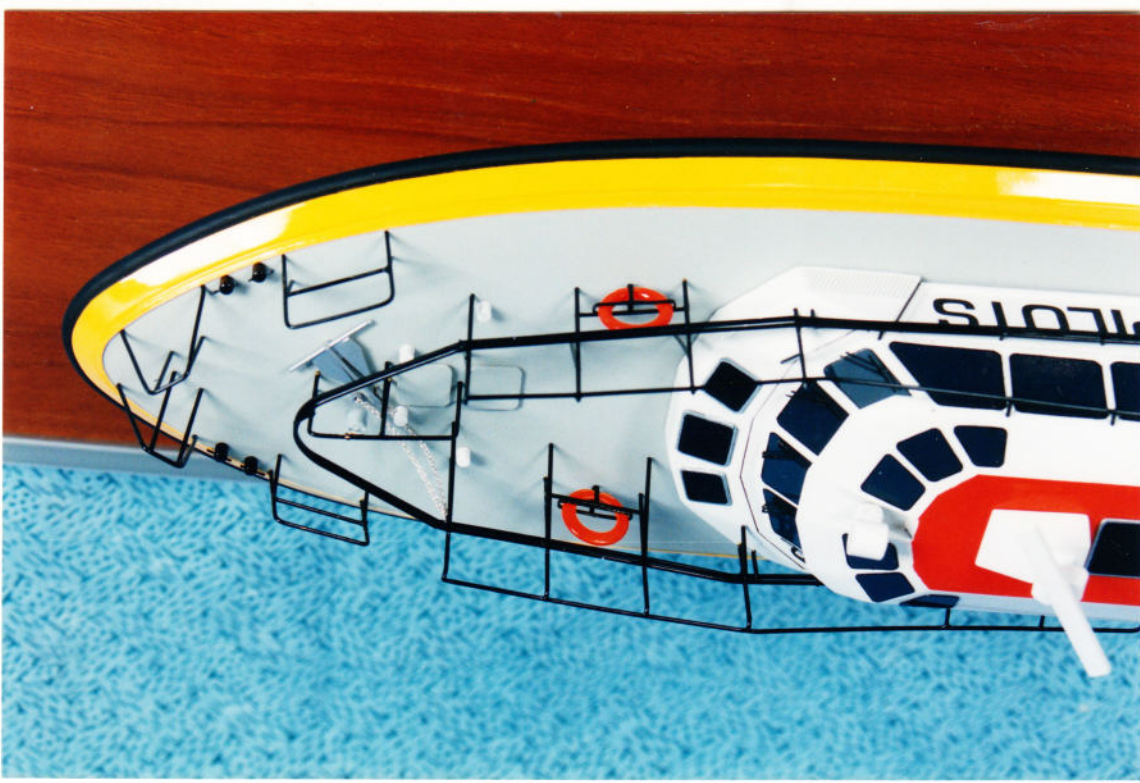



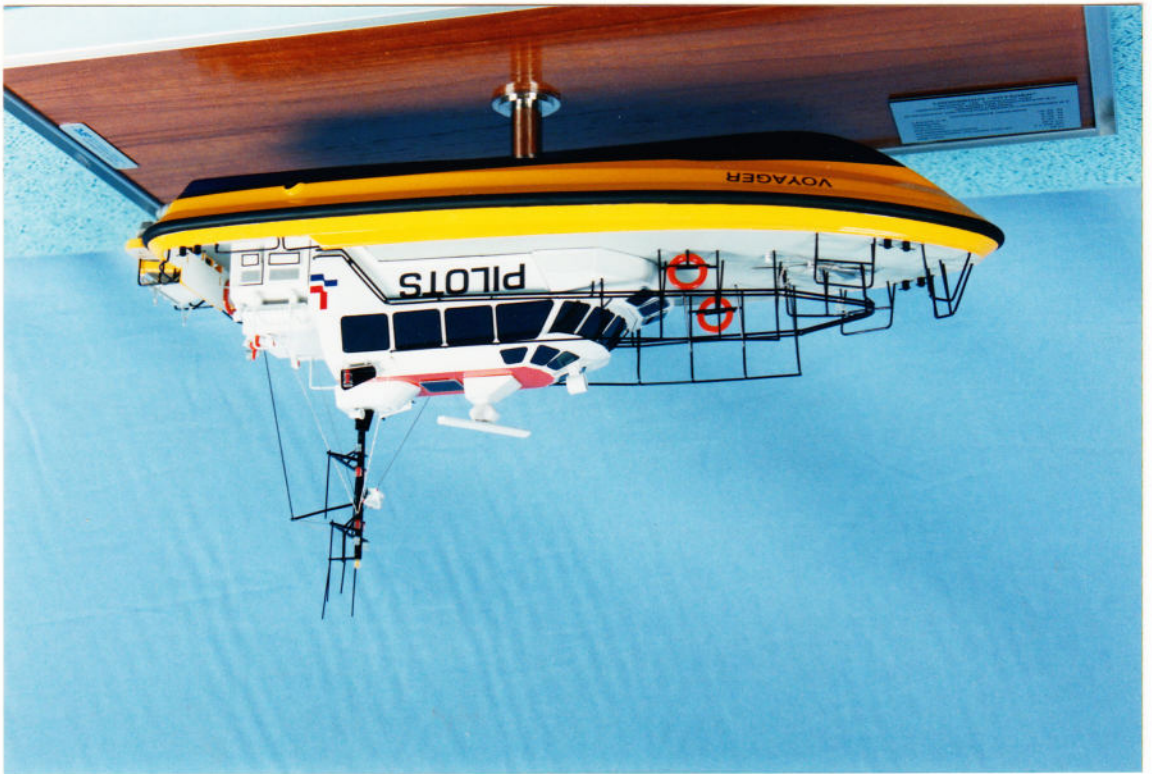



ENGELAGR
DISCOVERY
(1 voor E.
1 voor ons)
1:50

tot. 170 mm.
12/5/98



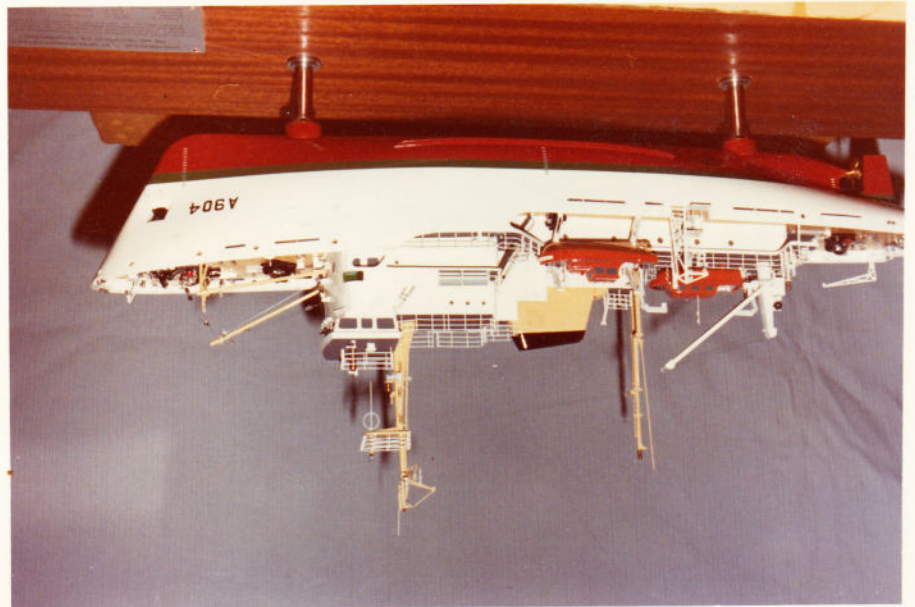
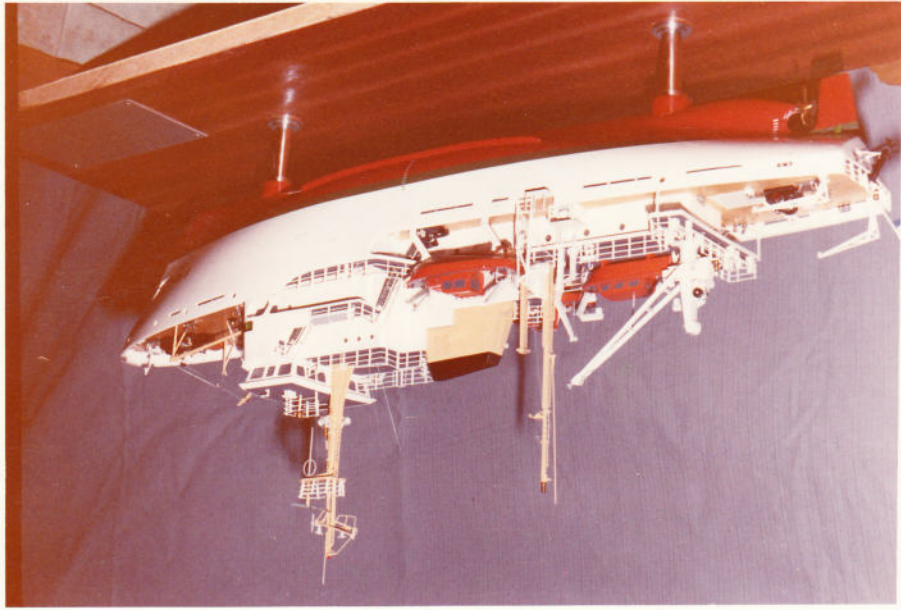
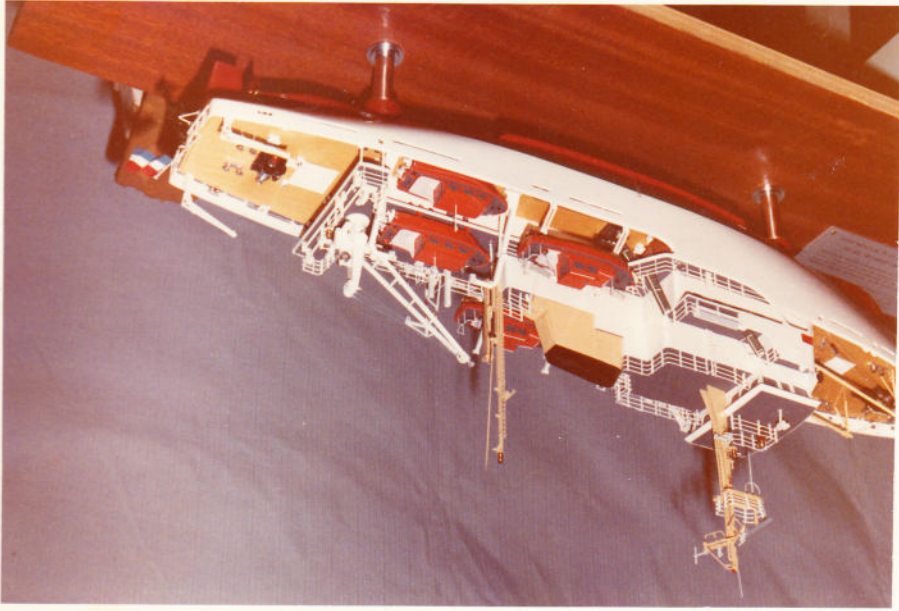

1973/74
Petersen
2
Beck's lens
Sprung v.



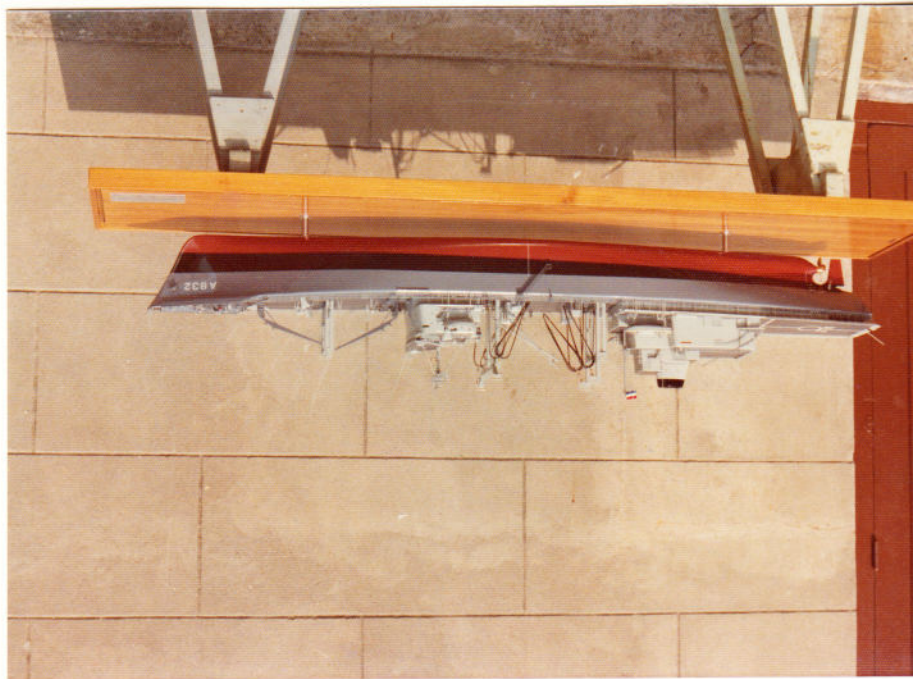
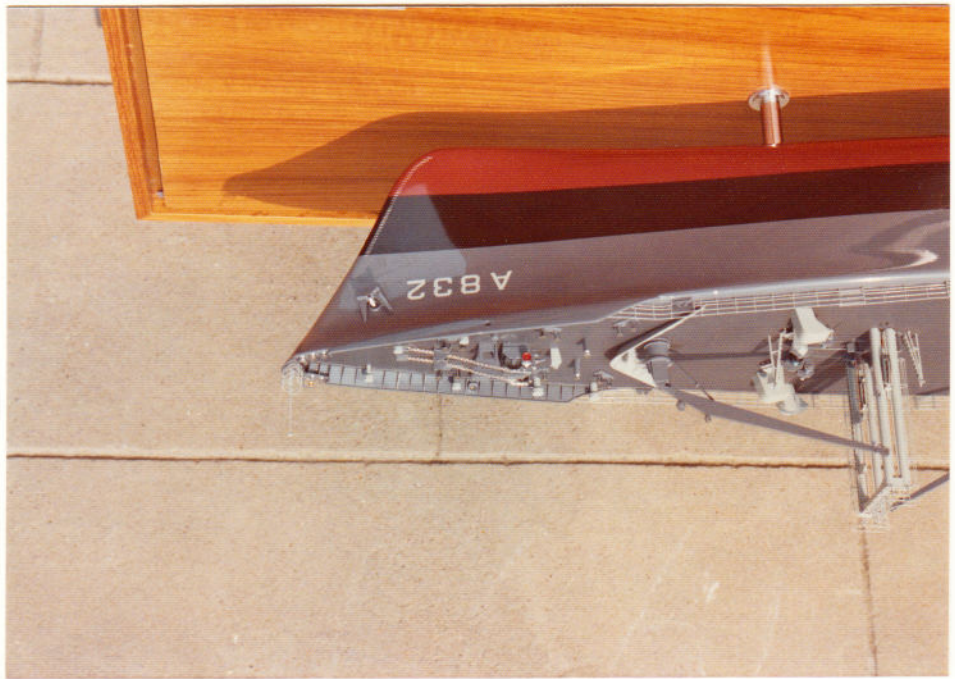
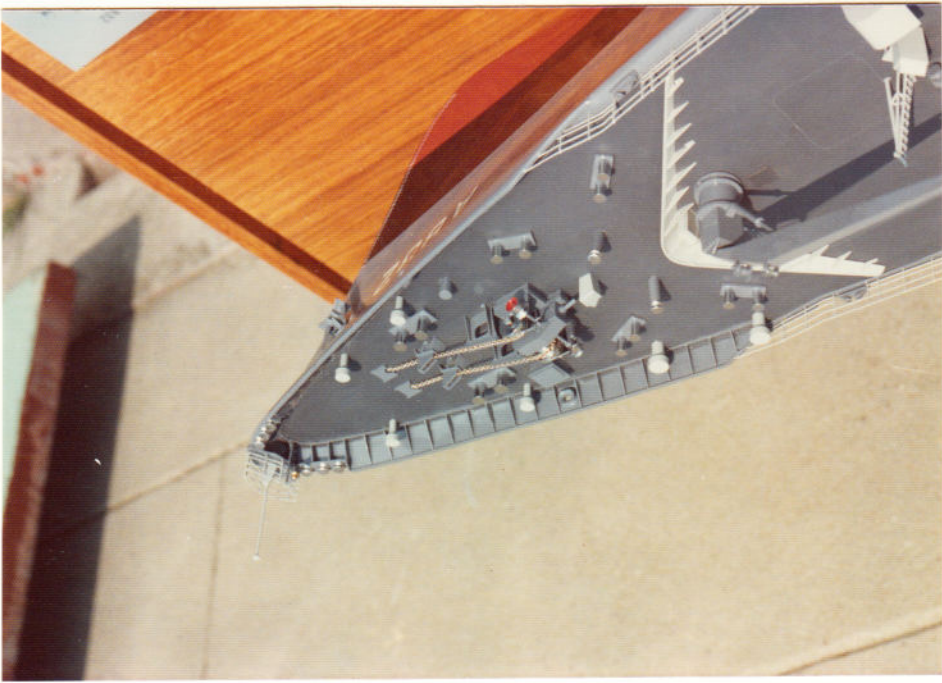

Guidebook
 here for
 840 was
 for 9

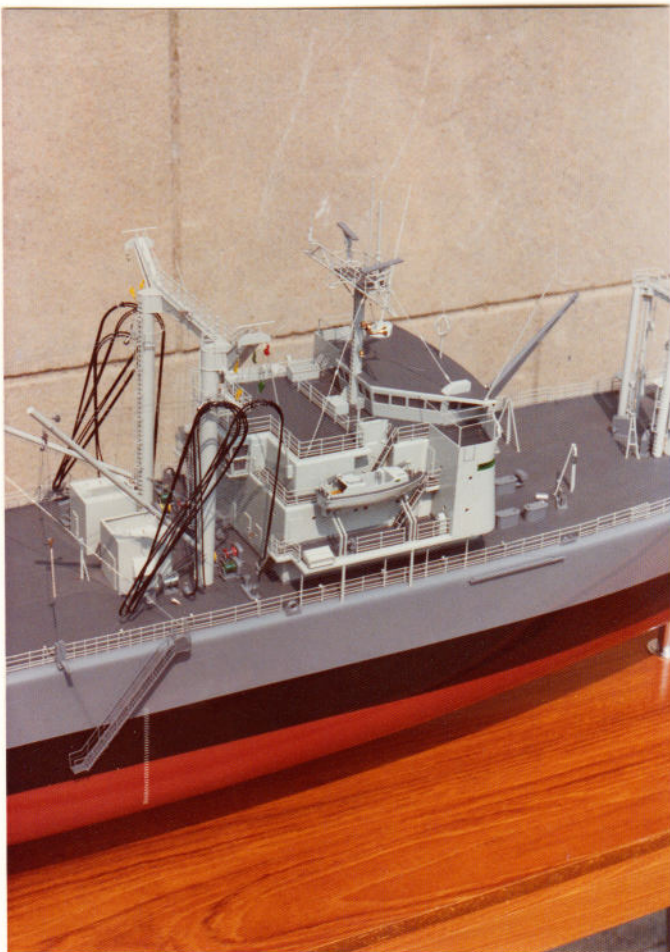
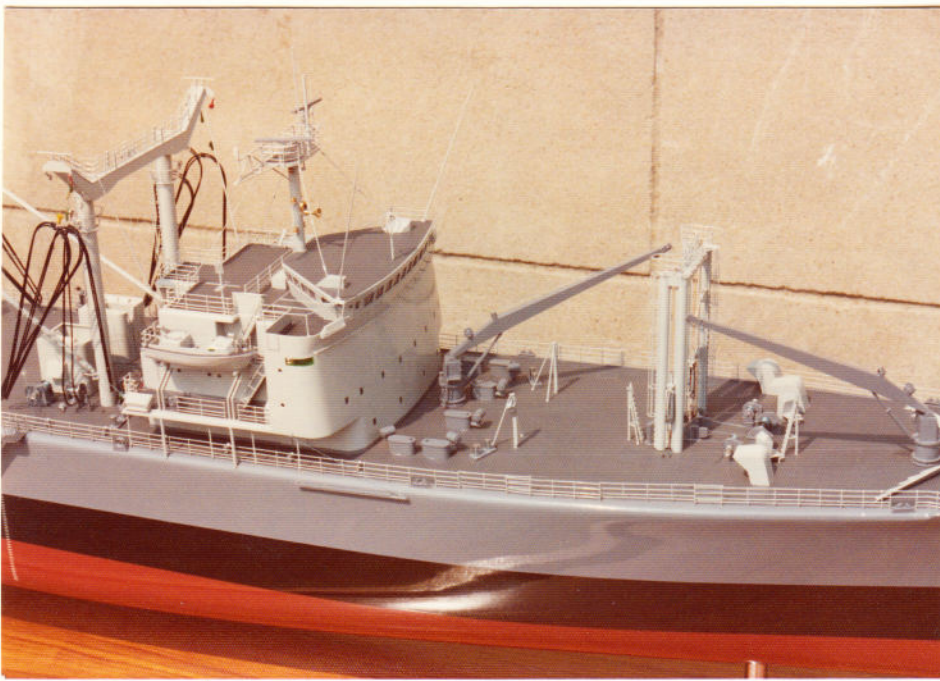

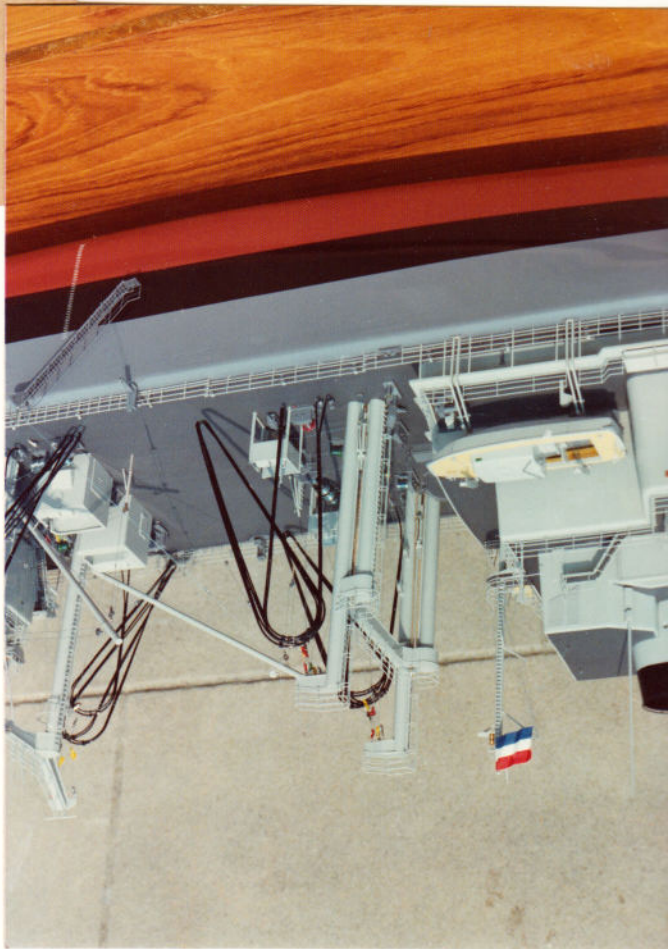
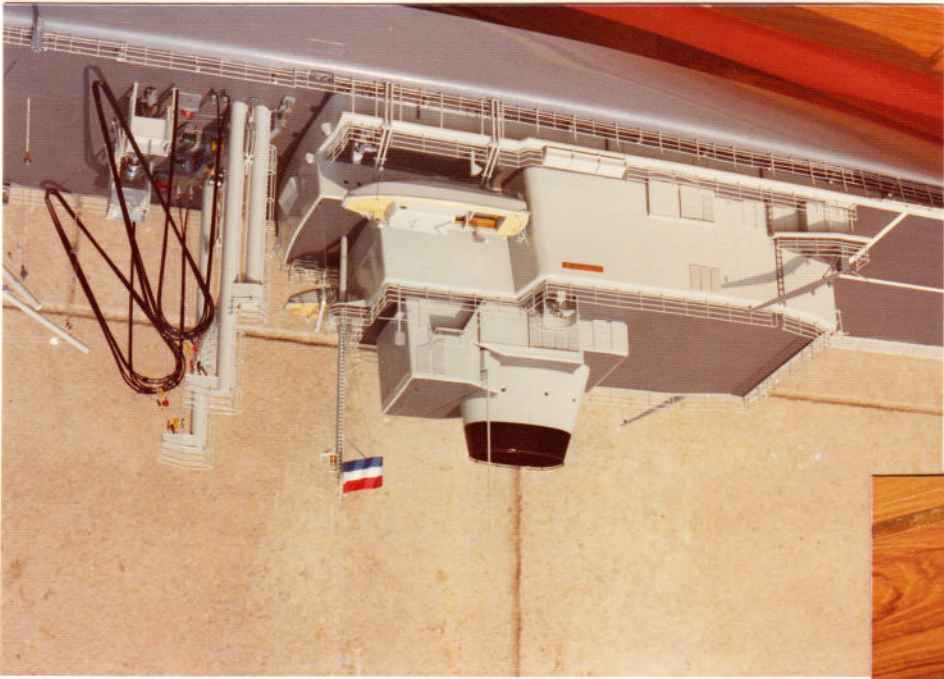
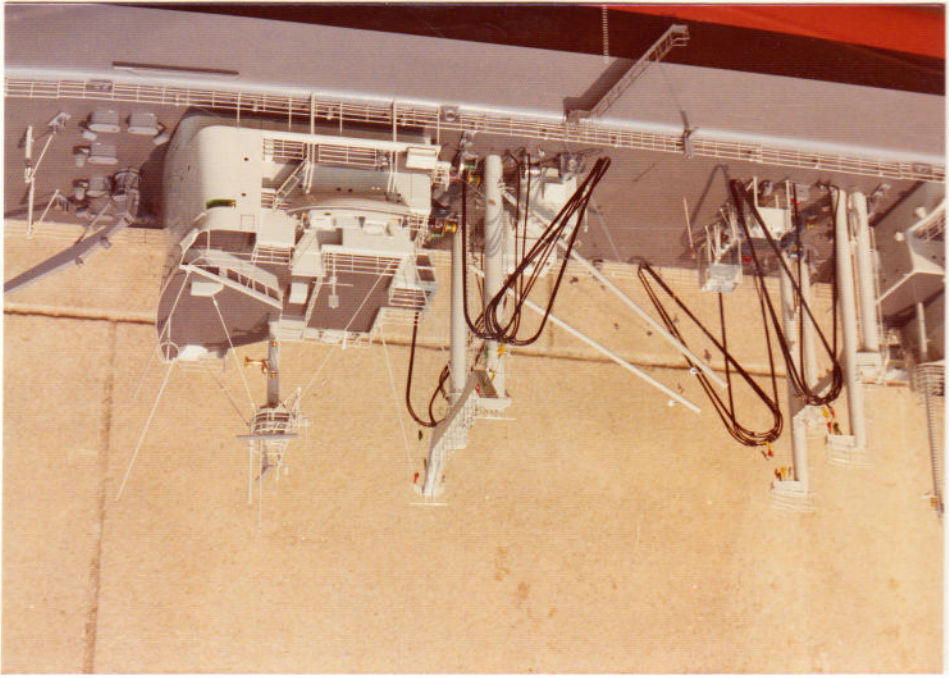

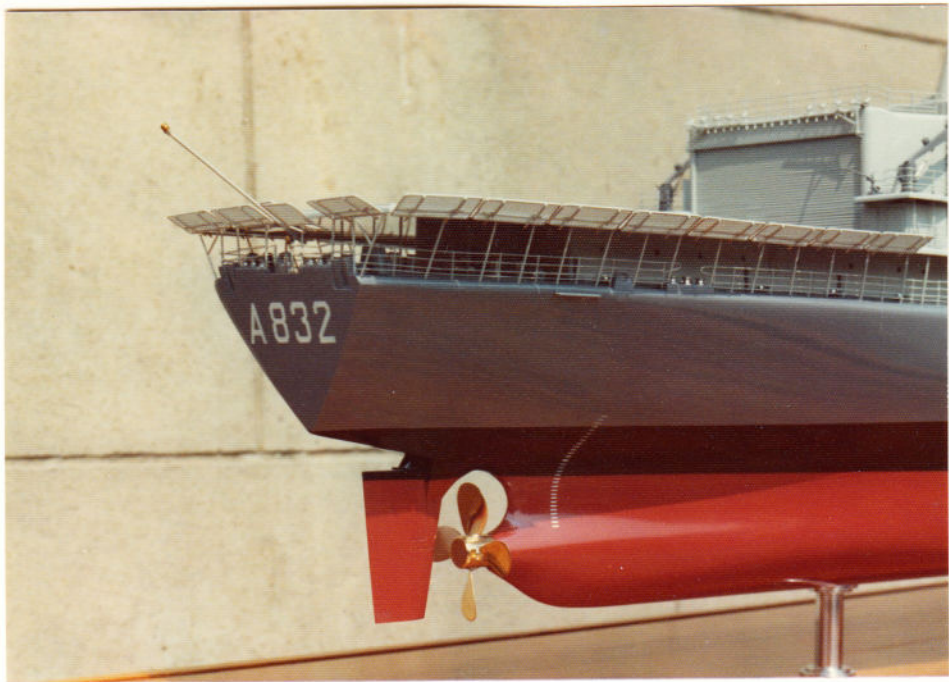
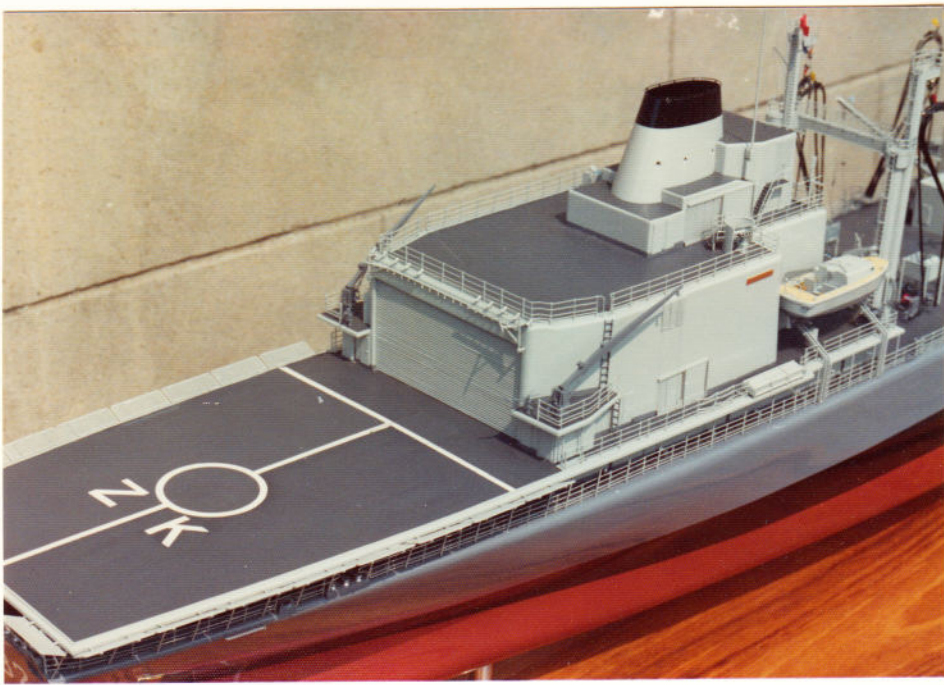

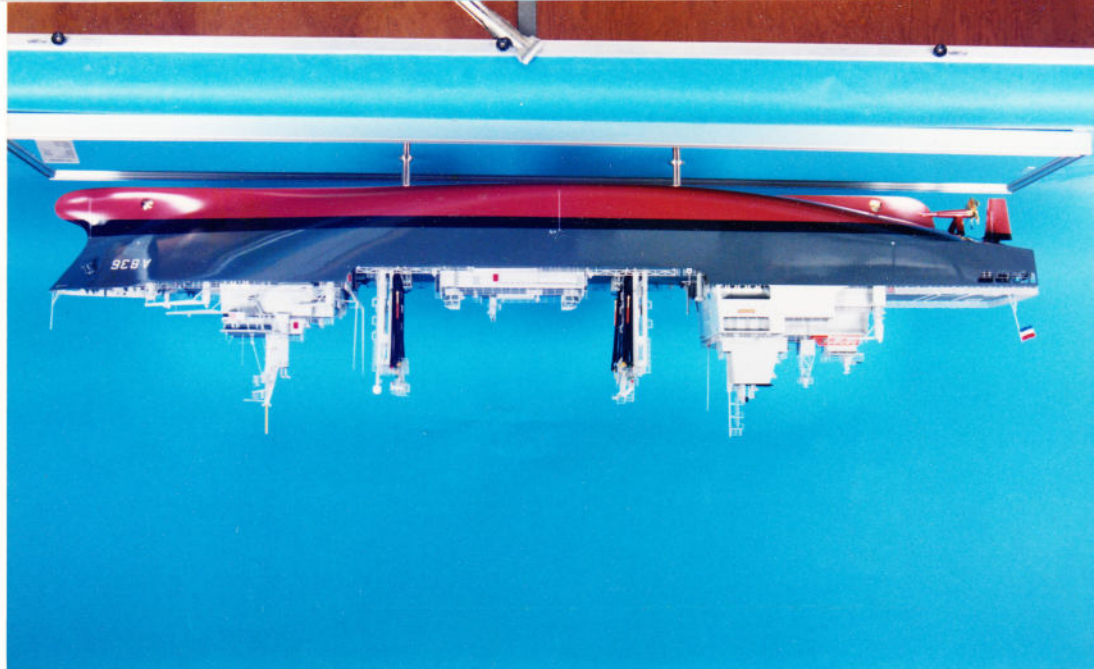
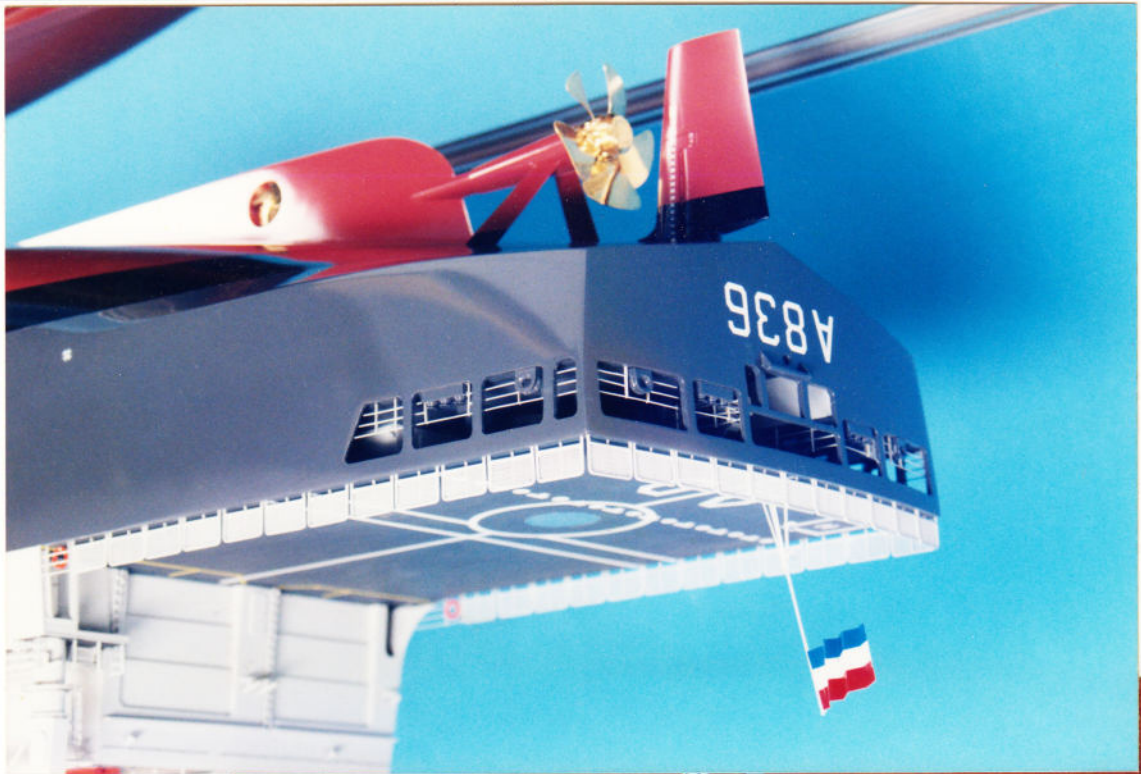
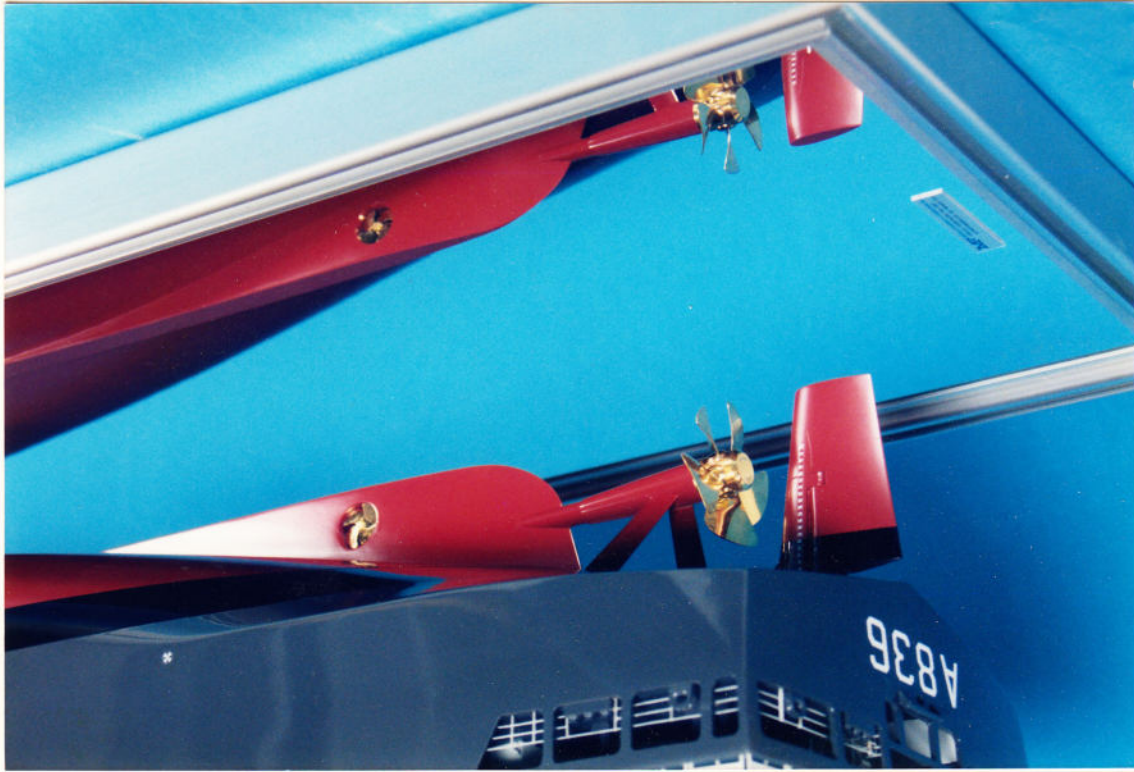

26/197
 166 cm
 bevoorradingschip
 1:100
 SCHULDE
 'Amsterdam'

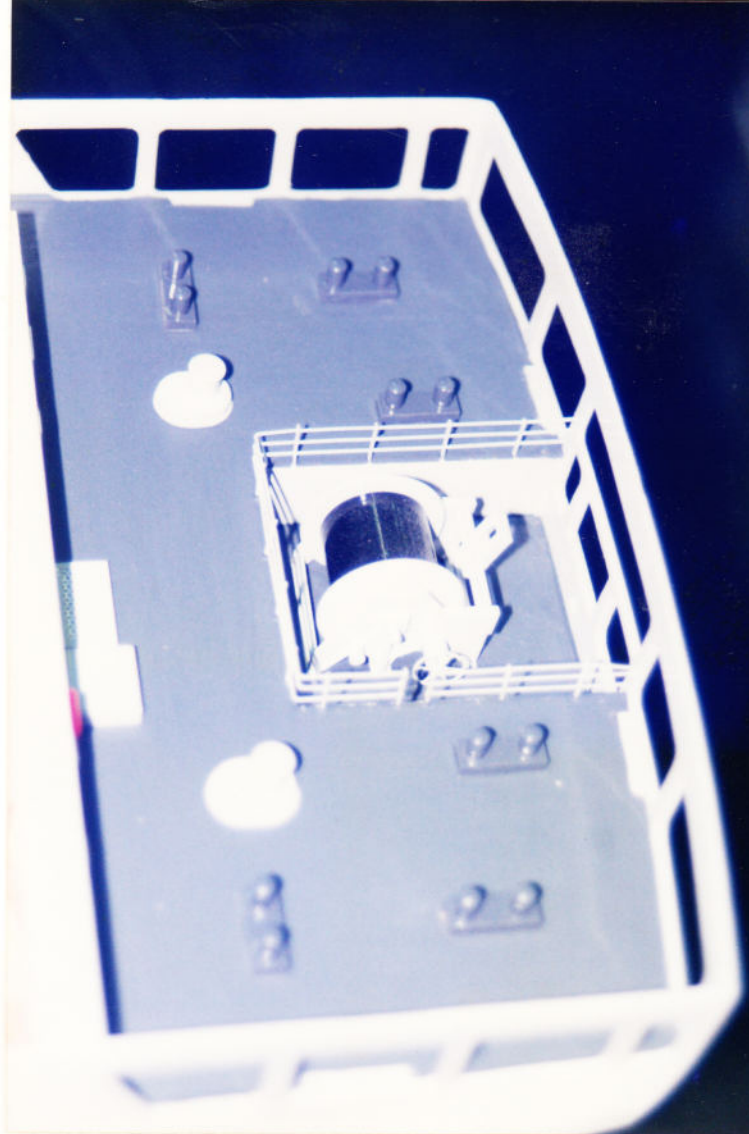
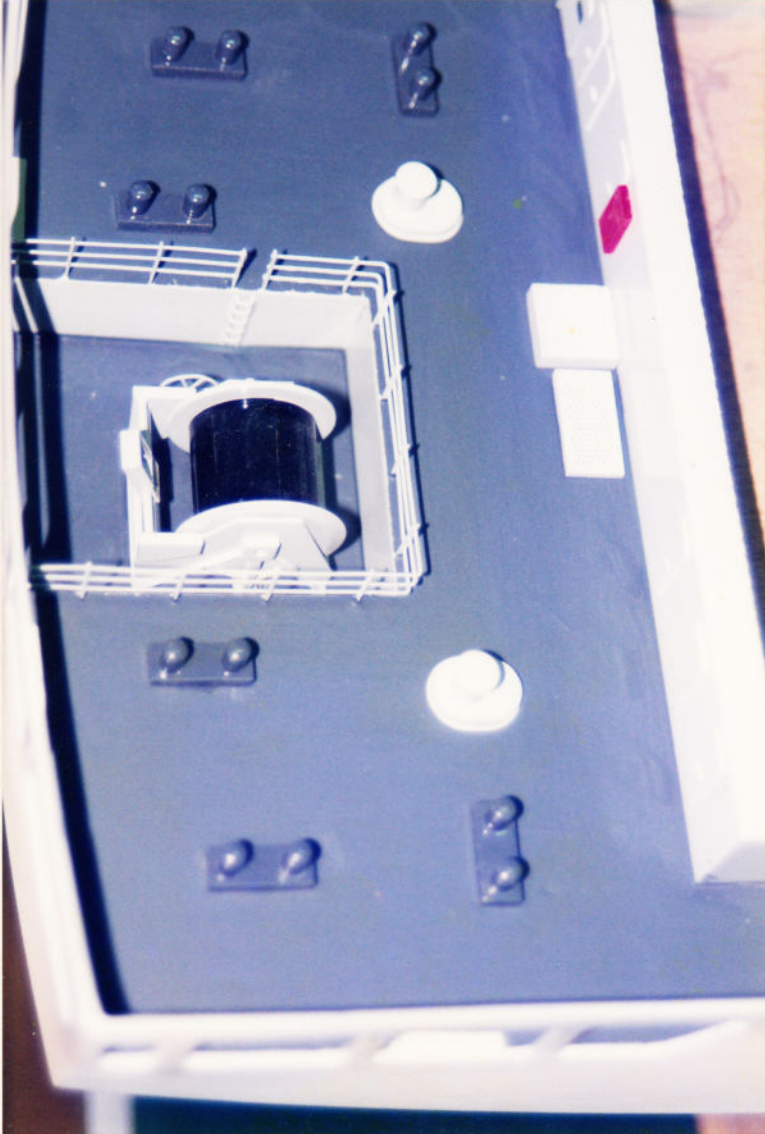

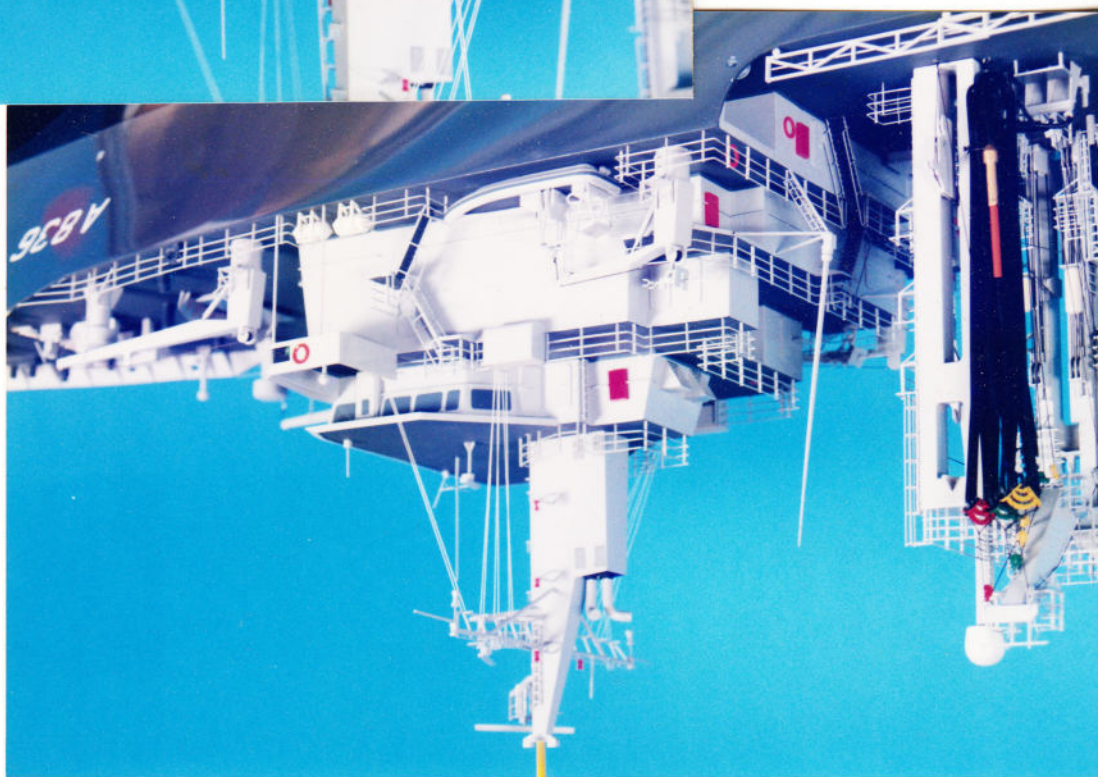
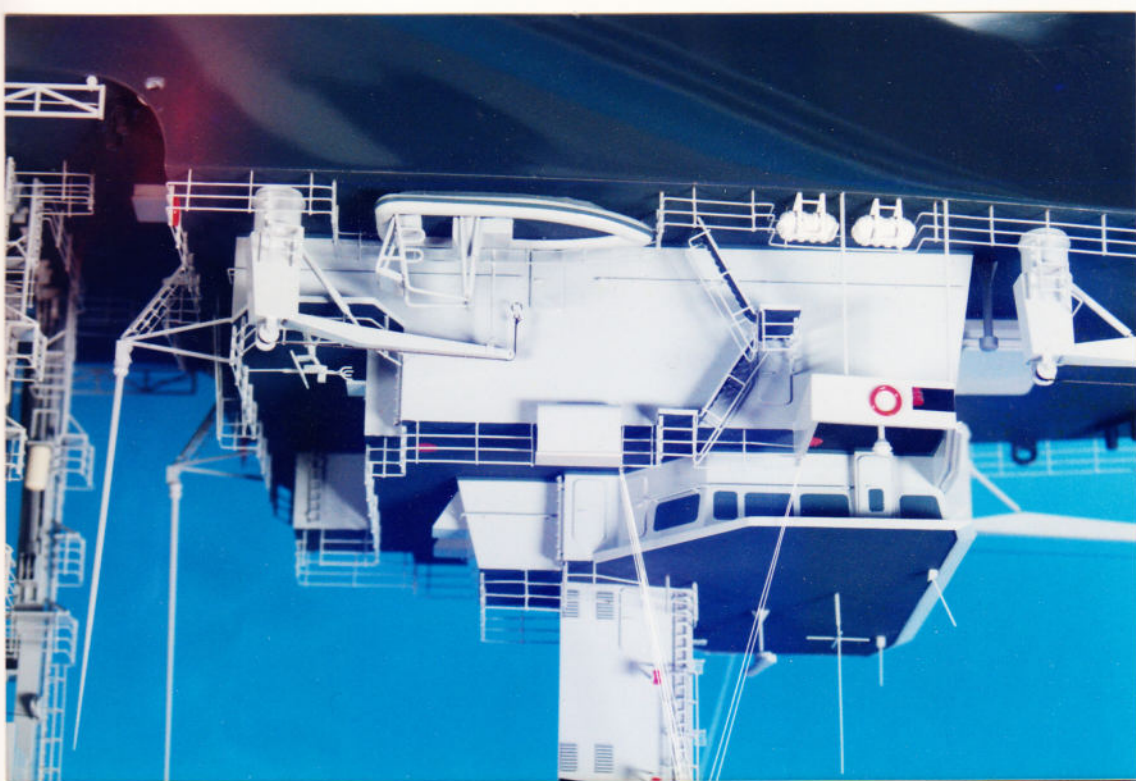



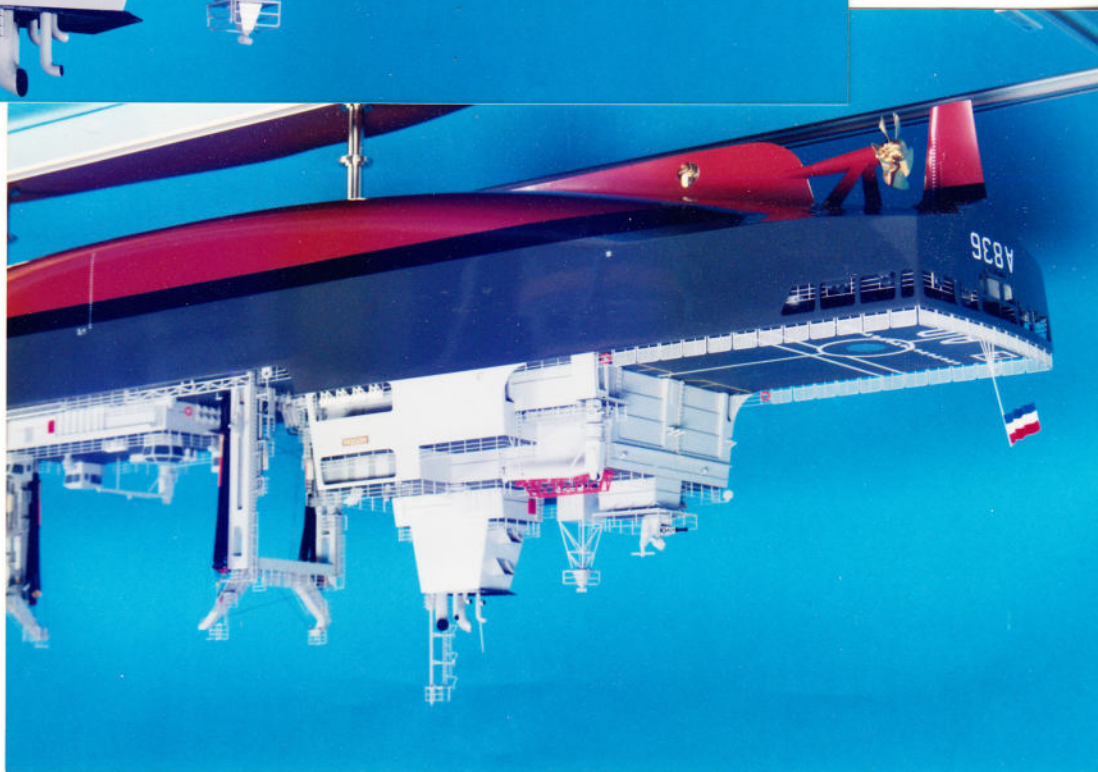
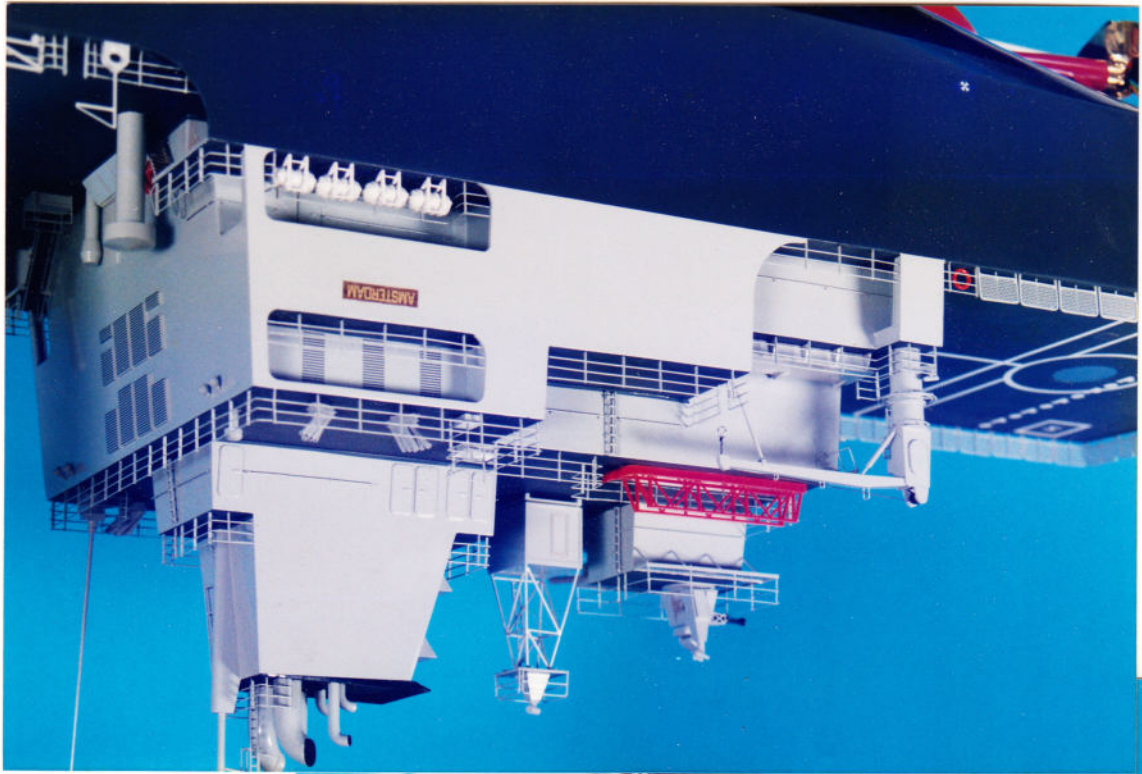
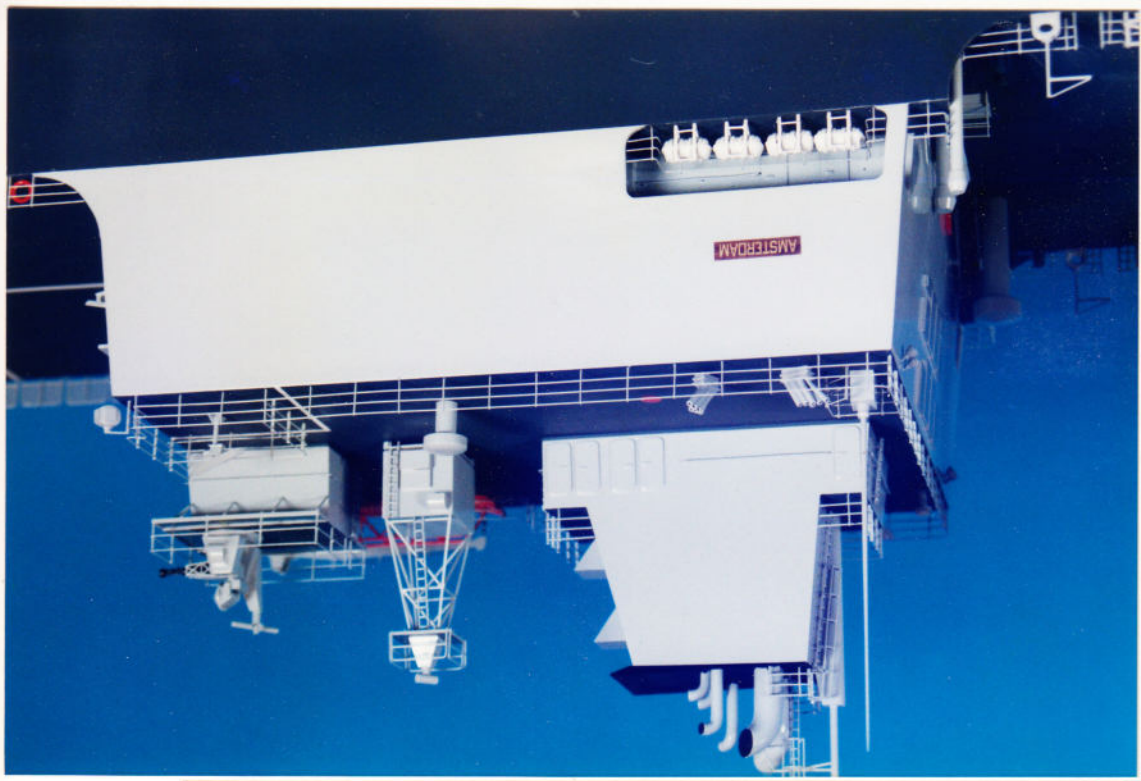

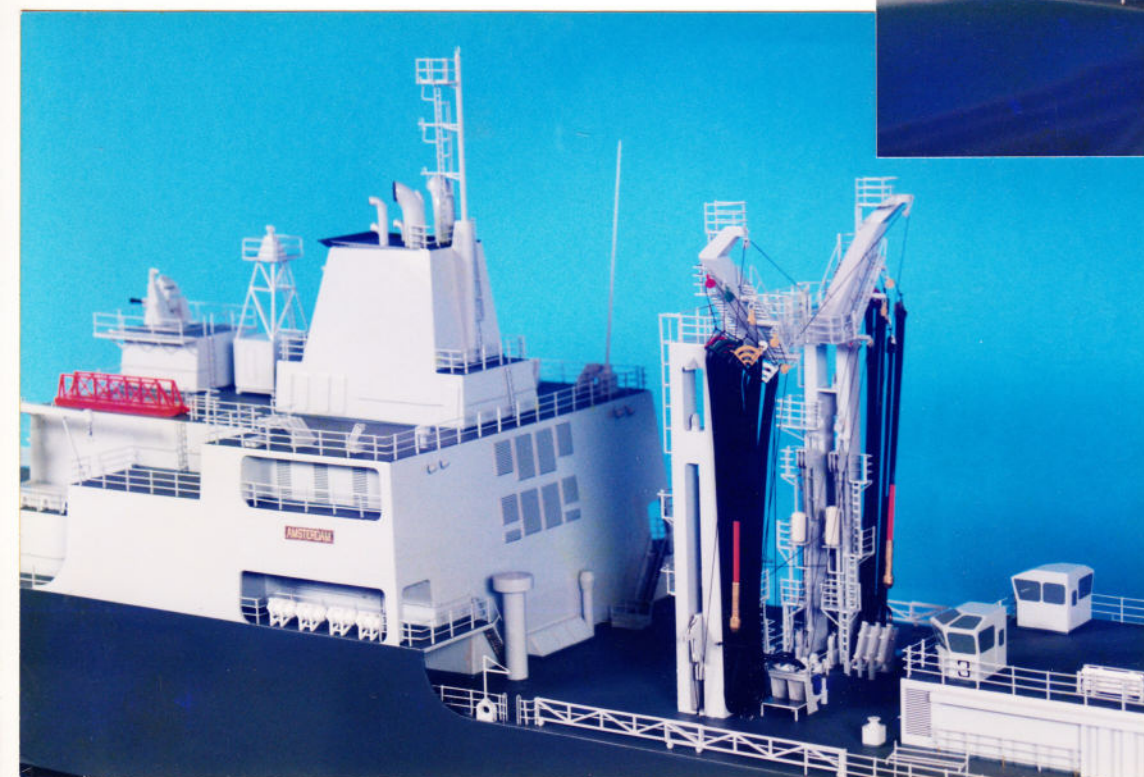

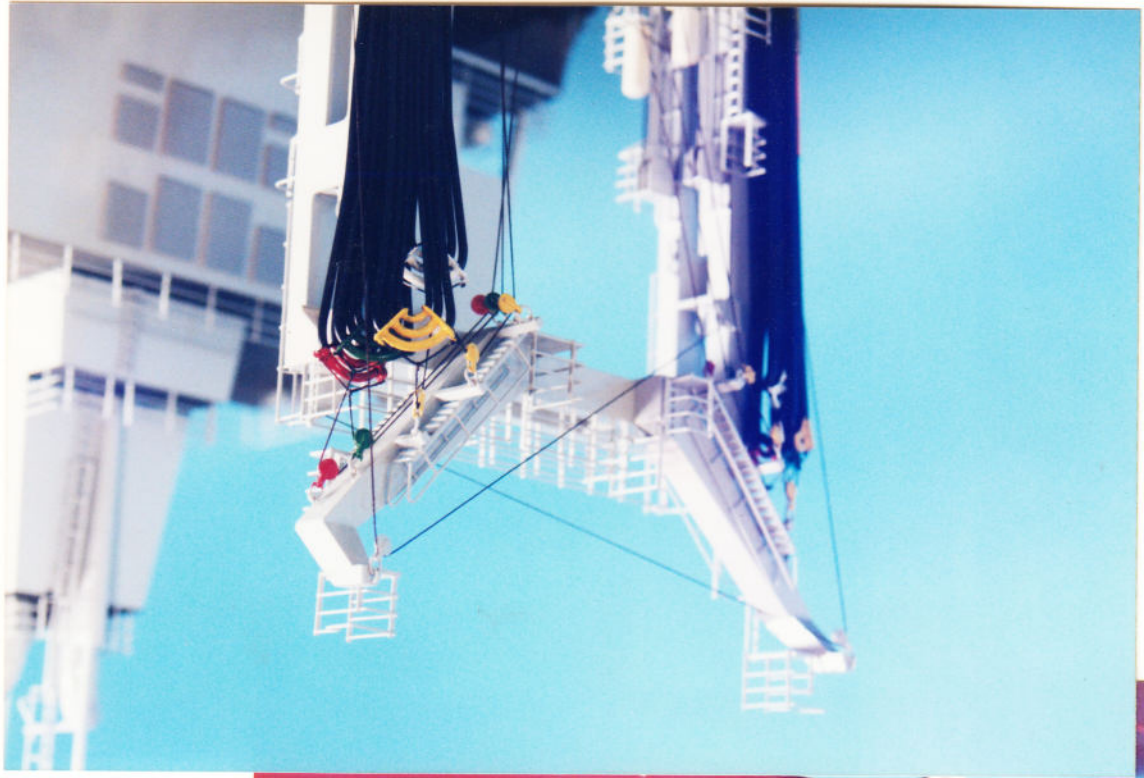
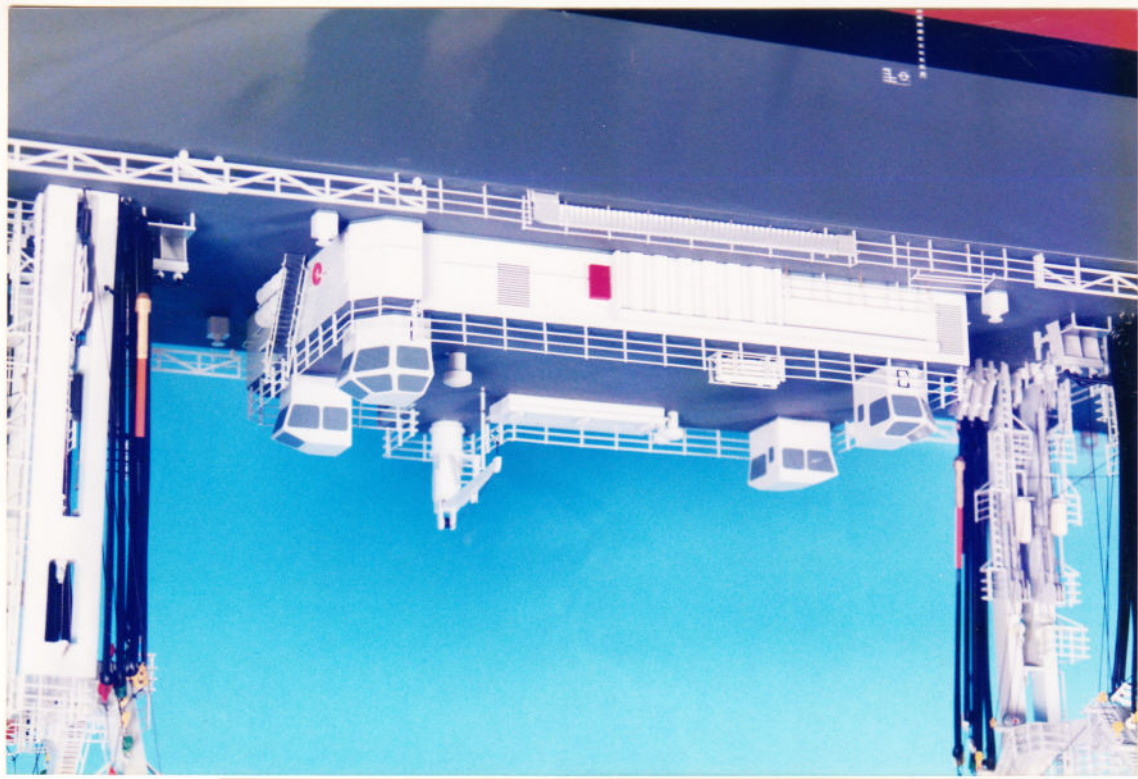

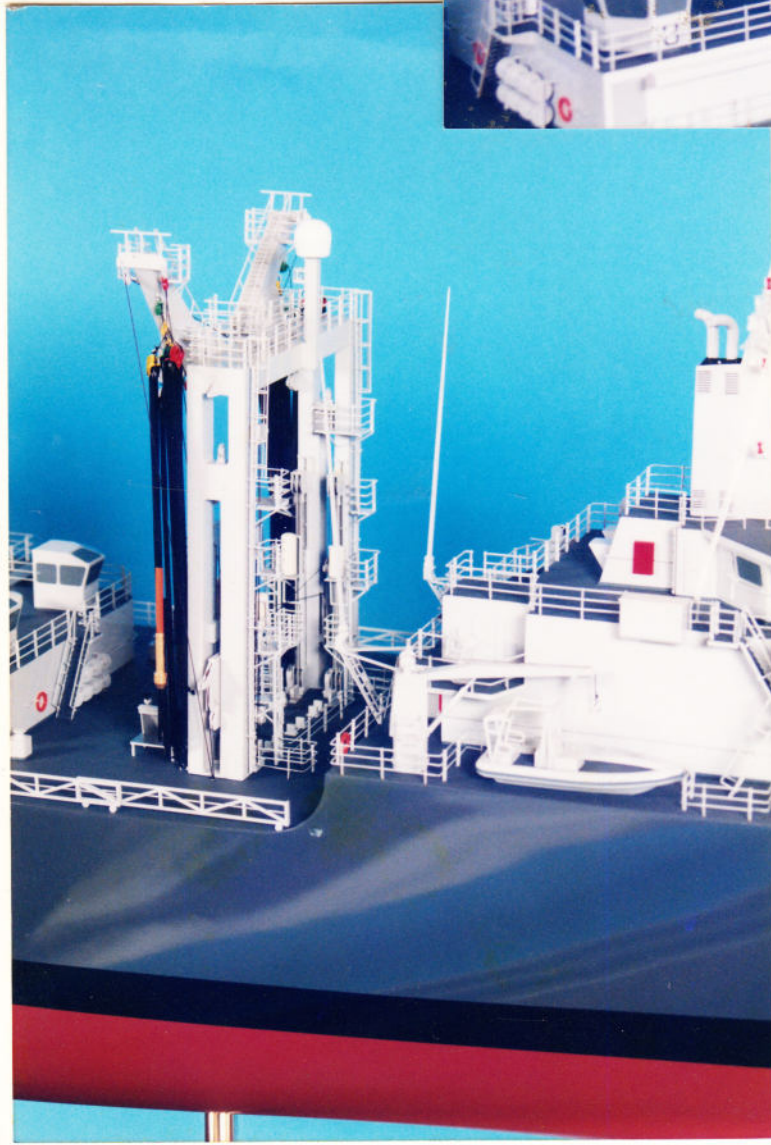
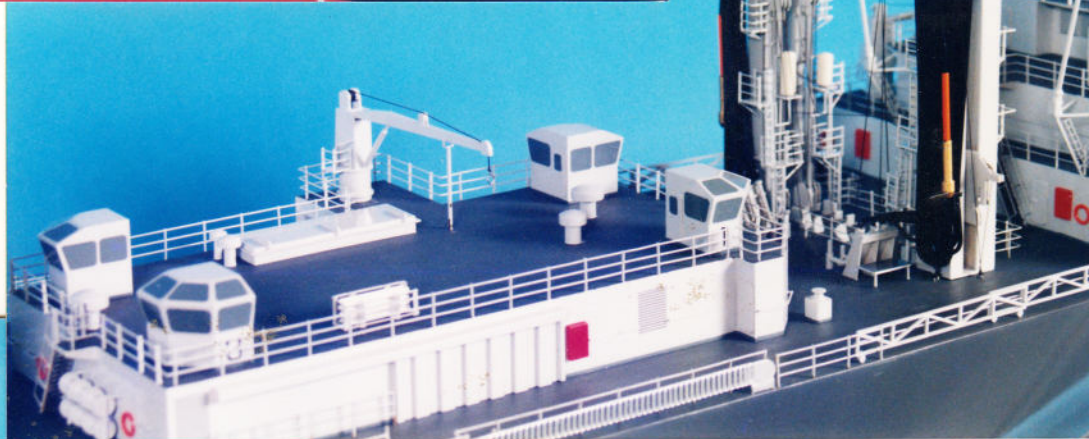

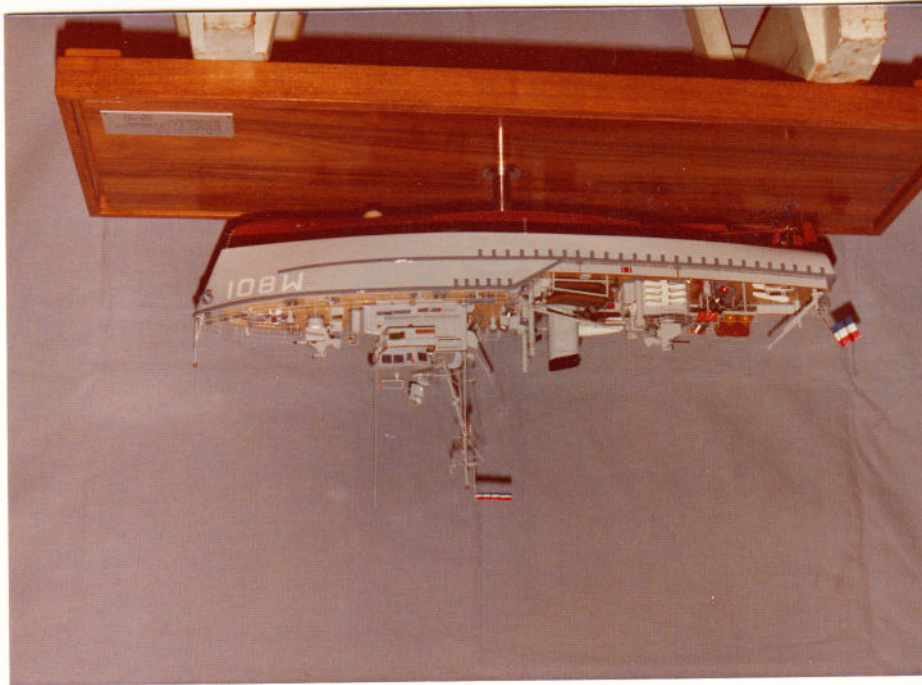
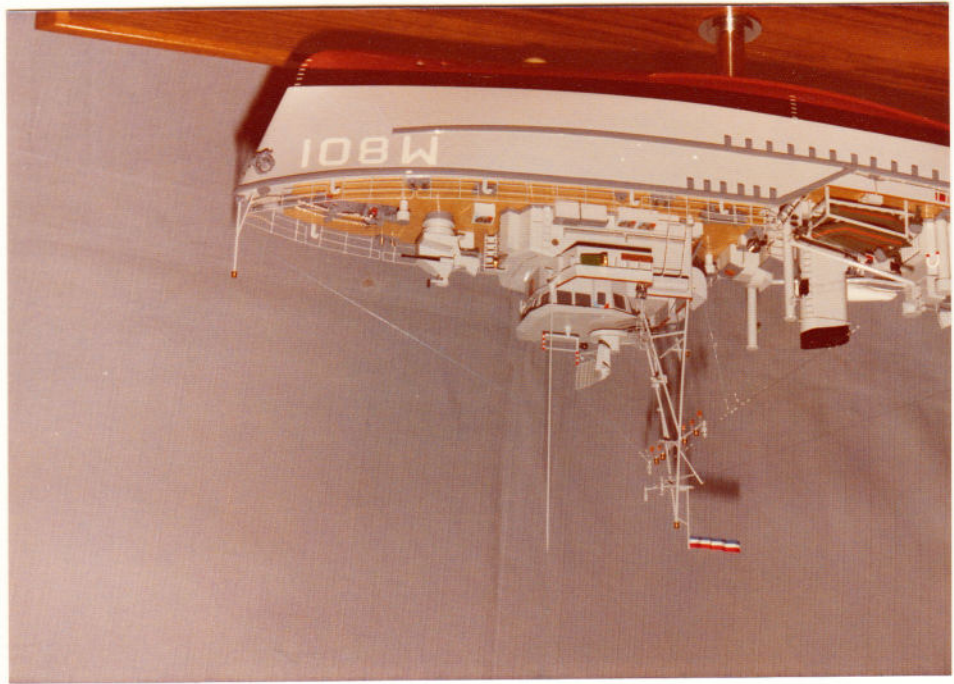
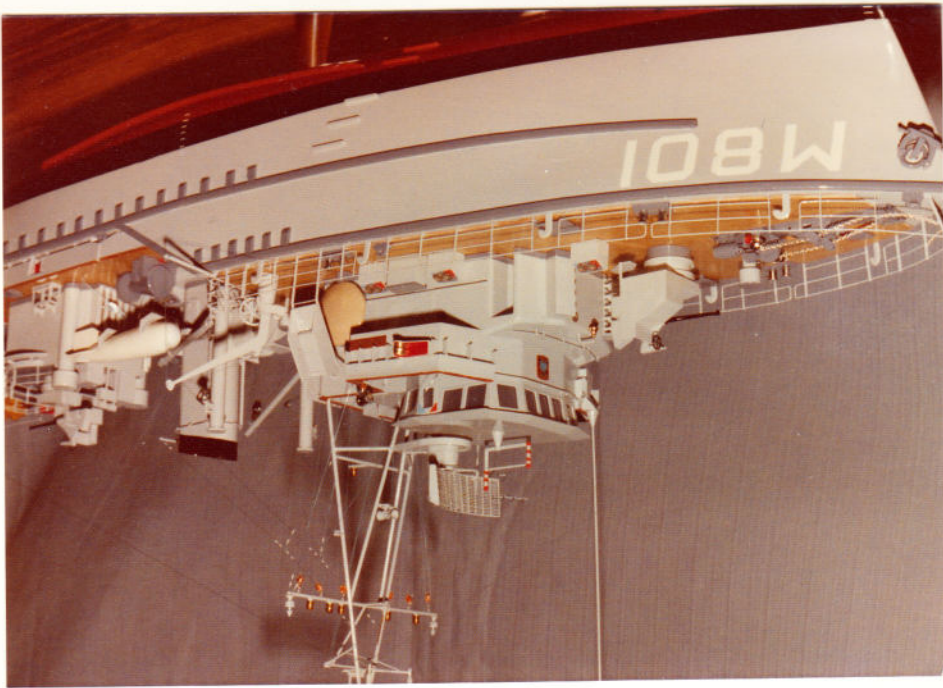

PH GIESSEN - DOKKOM
MAYENBERGER
"DOKKOM"
1:75.
2 STUKS 633 mm.
jan. 1975.



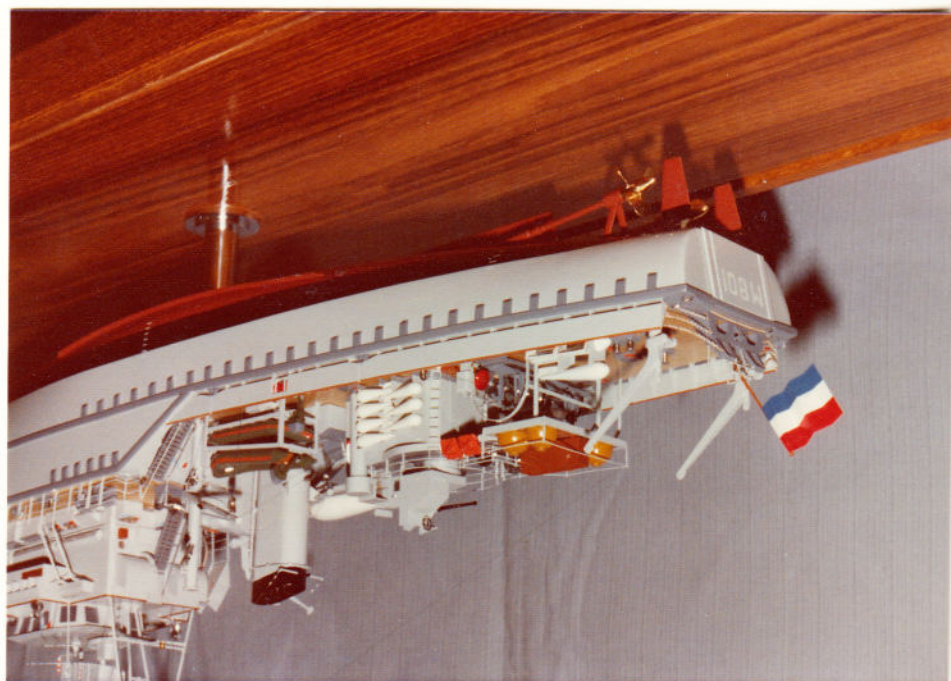
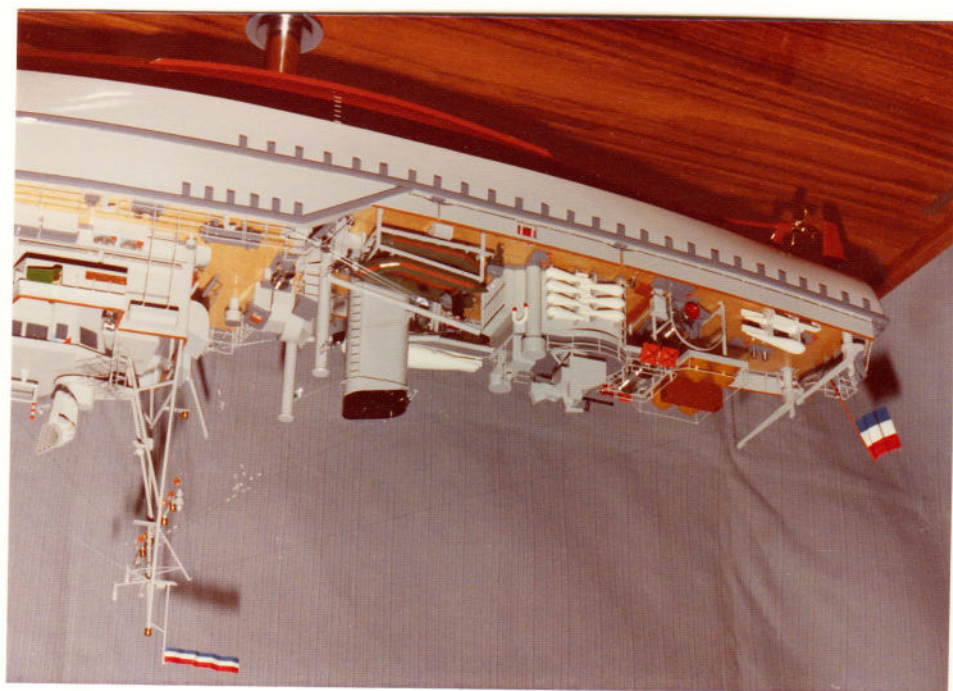
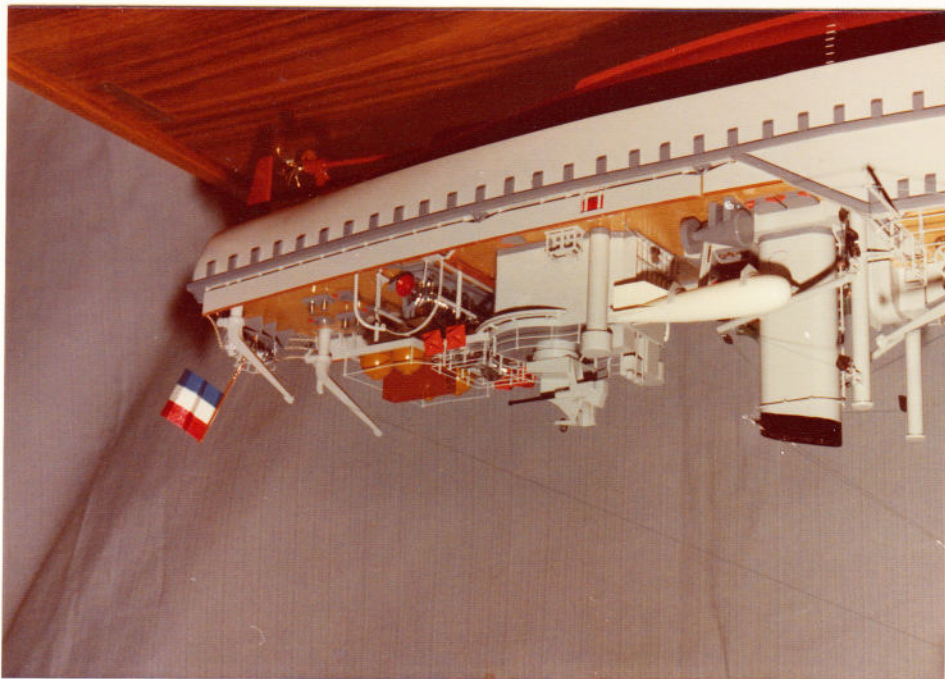

Ulf Björsson - Sönder
 MYNENÄNGER
 "DOKUM"
 1175
 OKTOBER 1974
 14N
 2 stuks 633 var.

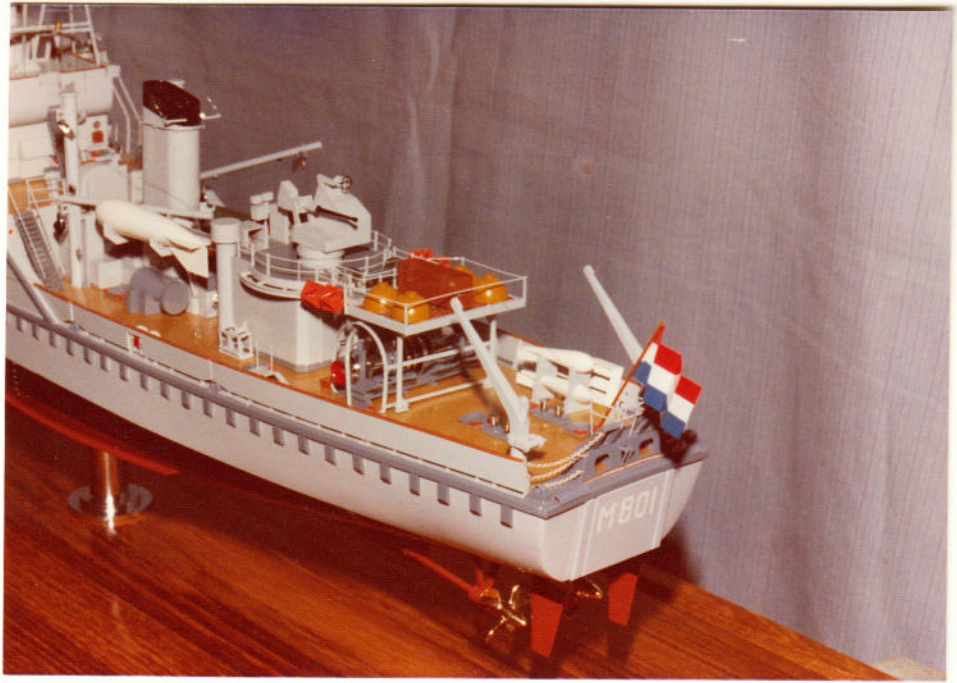

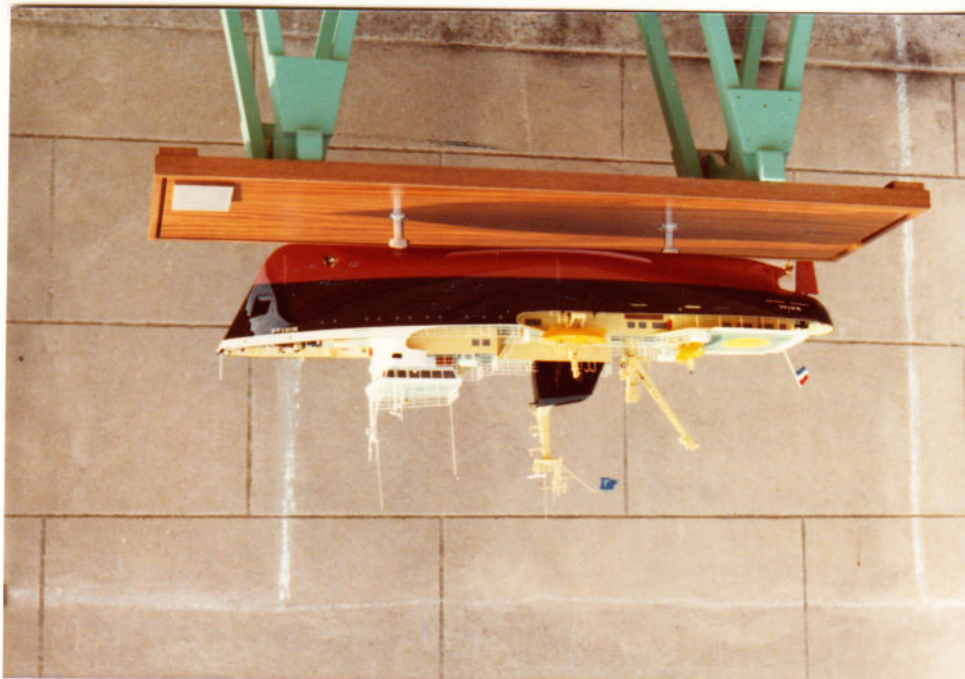
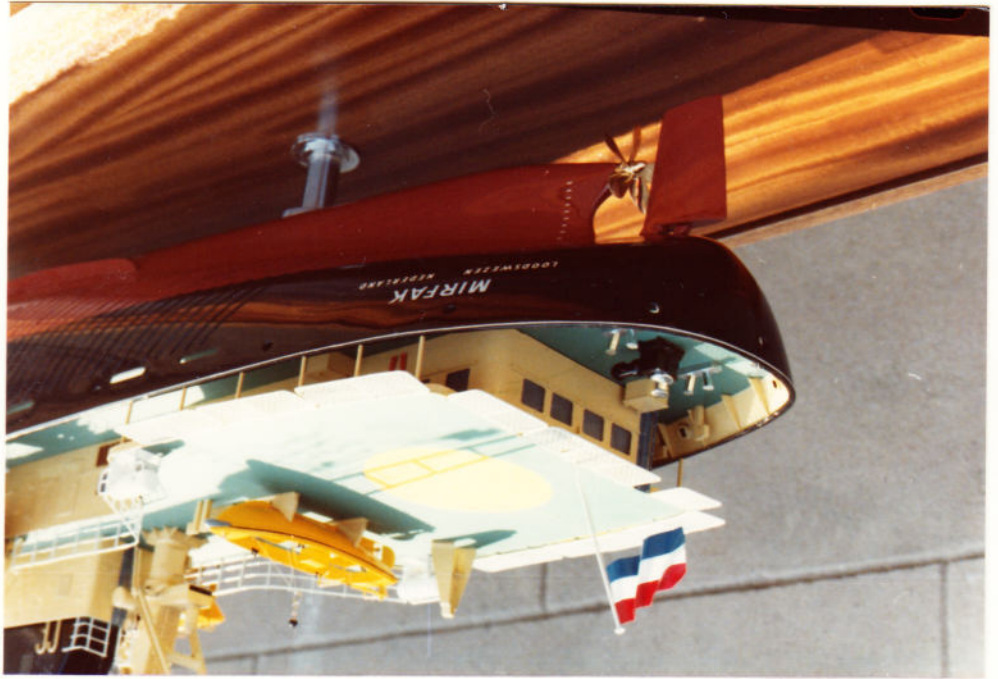
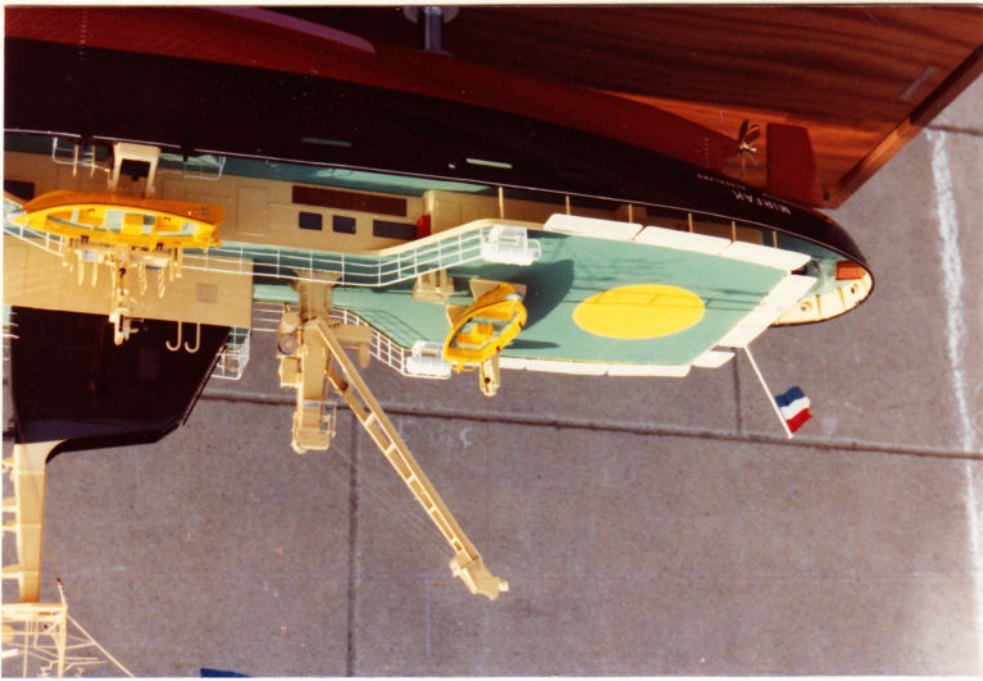

161 mm

21-4-78
 1:50
 VOYR & ZH.
 LOODSWERK



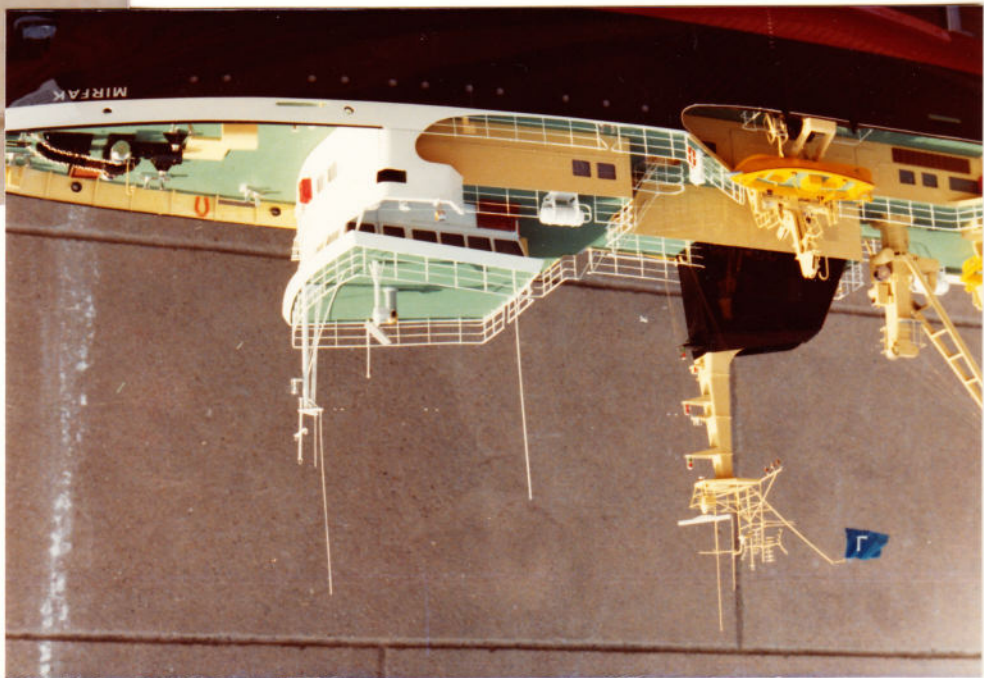
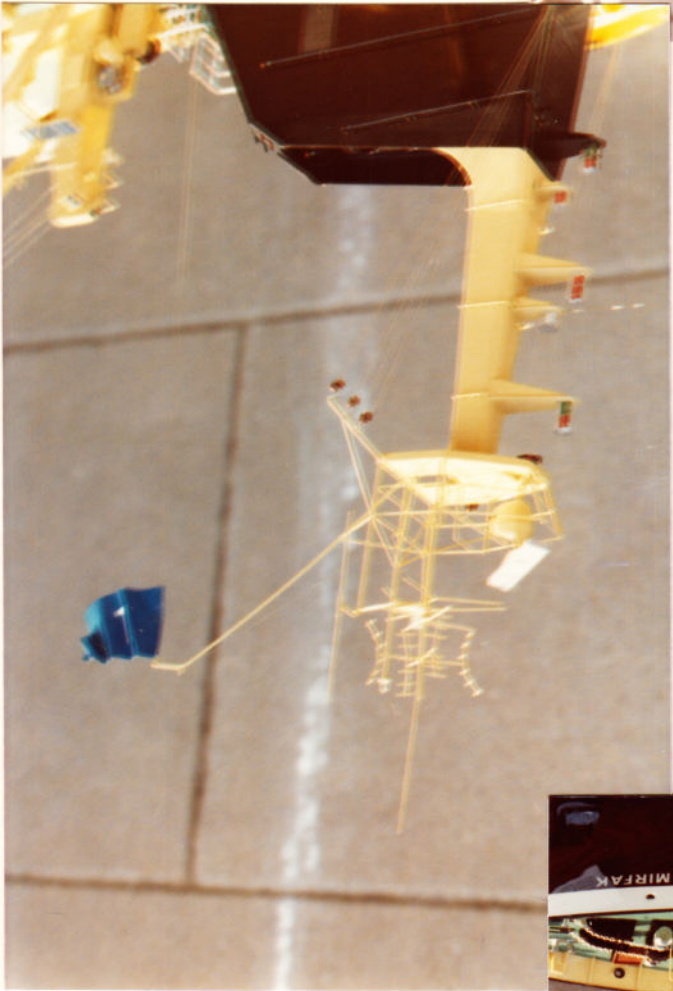
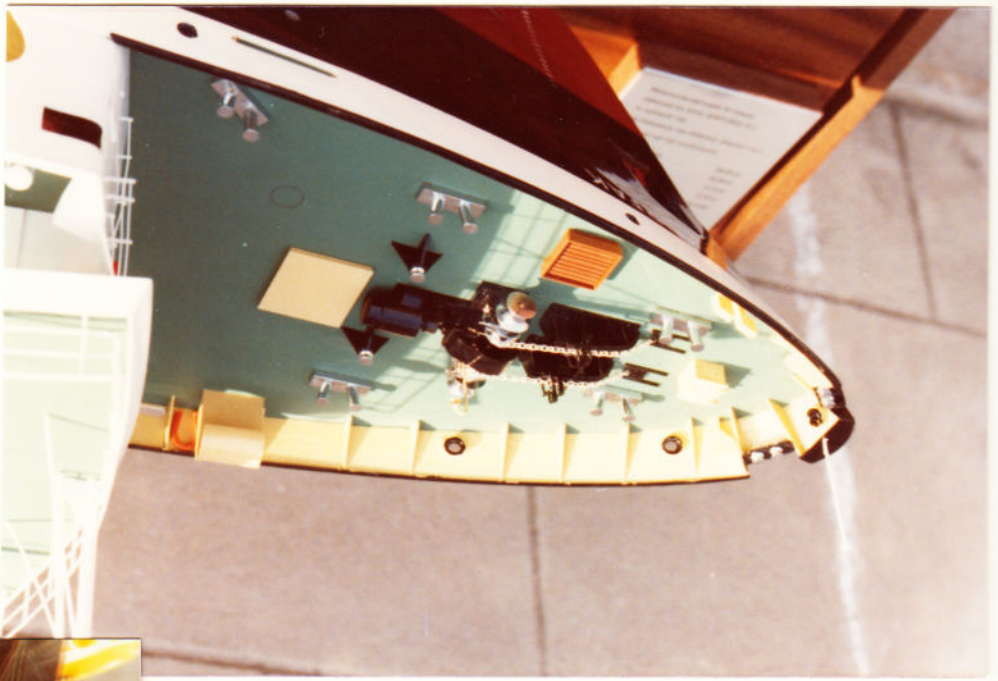



Projektionsmodell des Schiffes
MIRFAK (D 100) 1971/1972
im Museum der Marine (Museum 100)
im Dienst der Bundesmarine
Name: MIRFAK
Typ: U-Boot
Länge: 100 m
Baujahr: 1971
Hersteller: LHM, Kiel, D.R.G. 1971
Projektionsmodell: 100 : 1 (1:100000000)

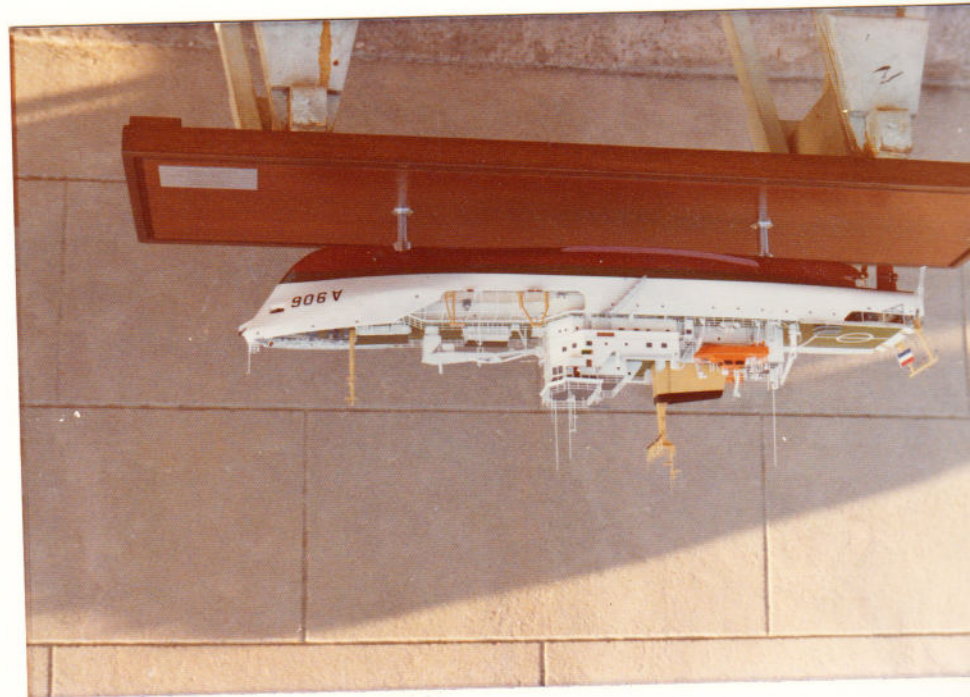
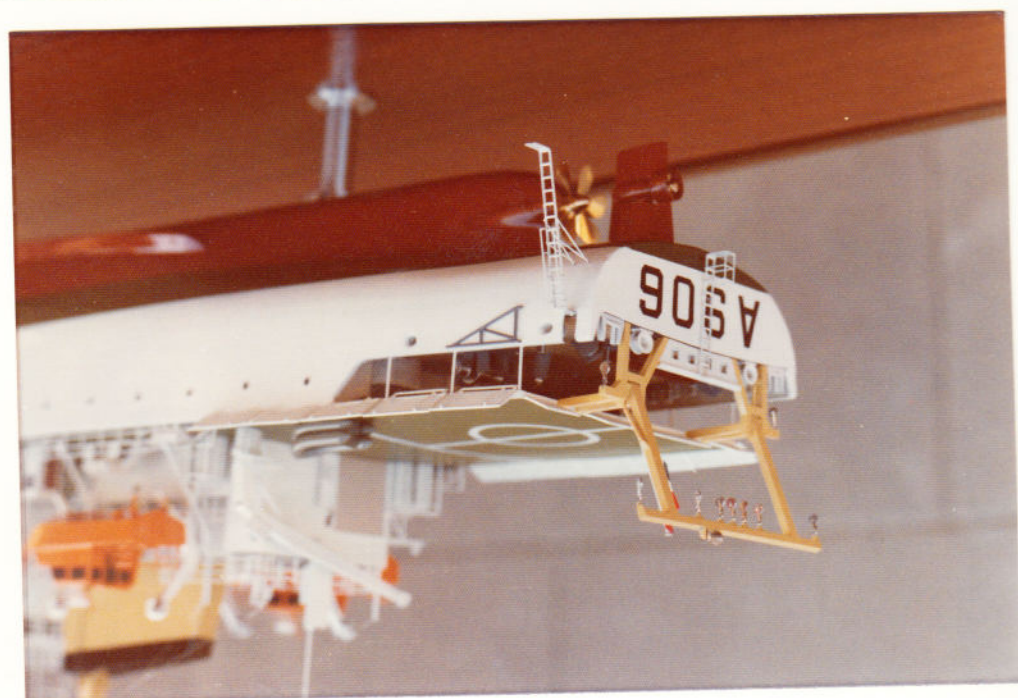
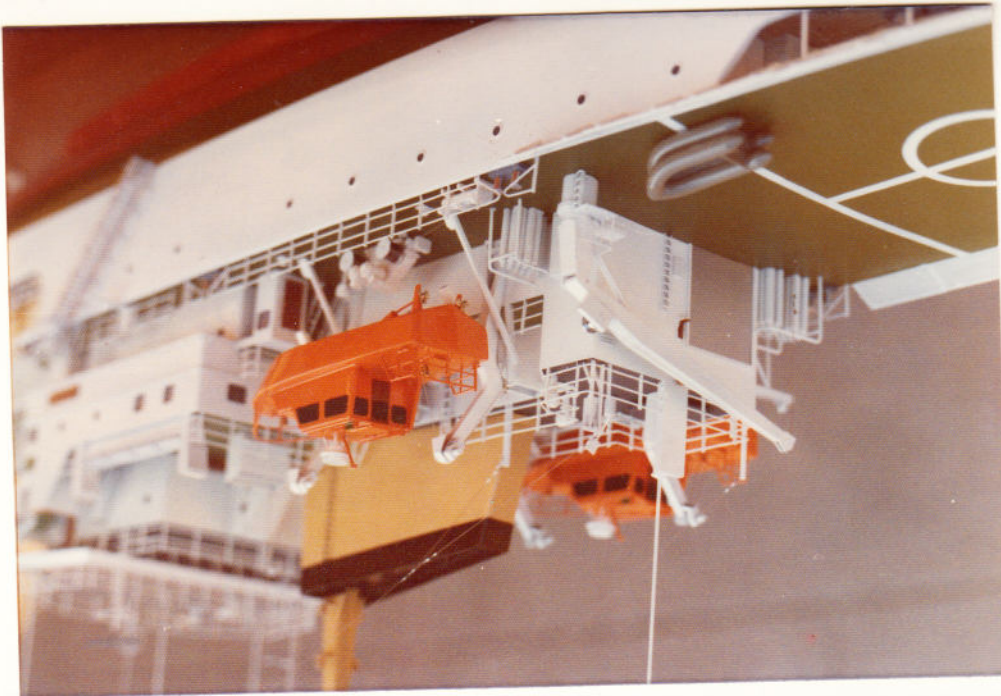

OCEANOGRAPHISCH BN. 618
 OPNEMINGSVAARTUIG
 TYDEMAN
 2x
 1:100
 17-12-77
 MERUDE
~~Merude~~
 1ste etage
 970 mm



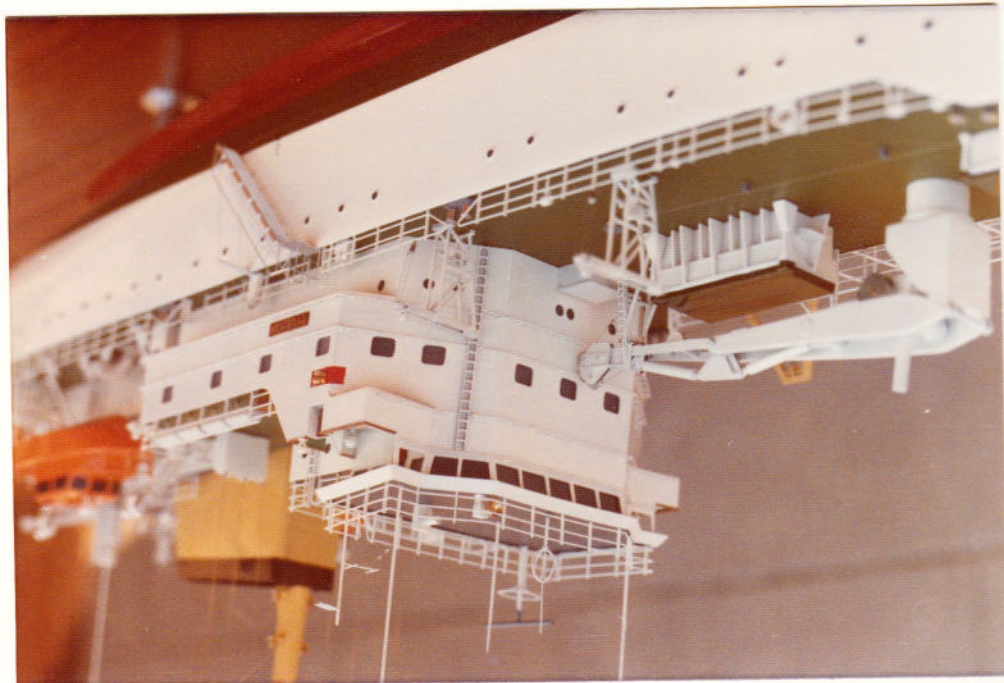
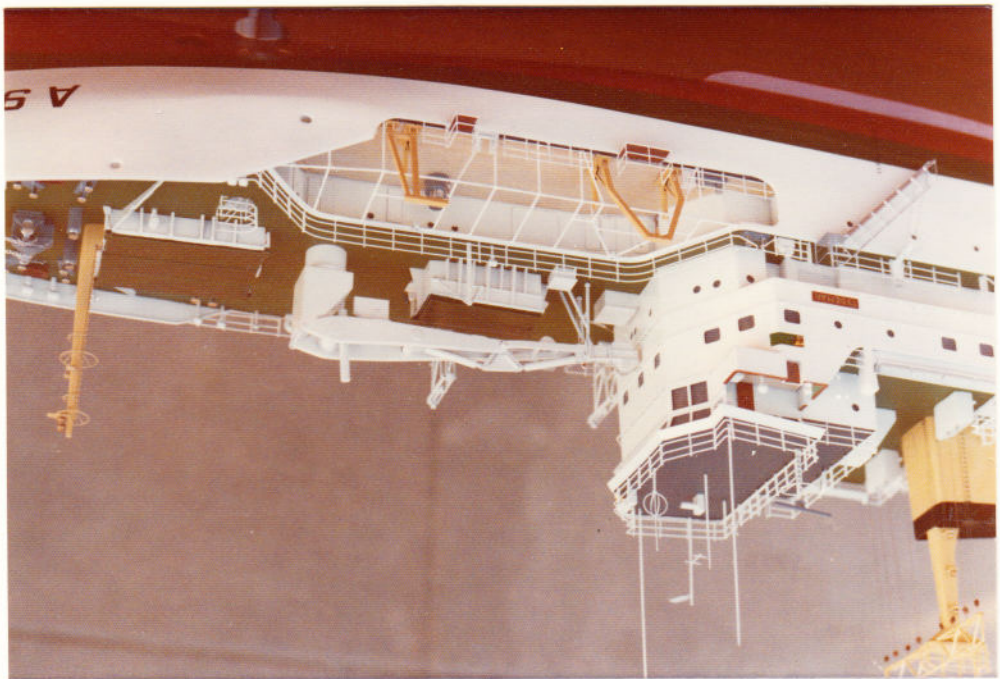
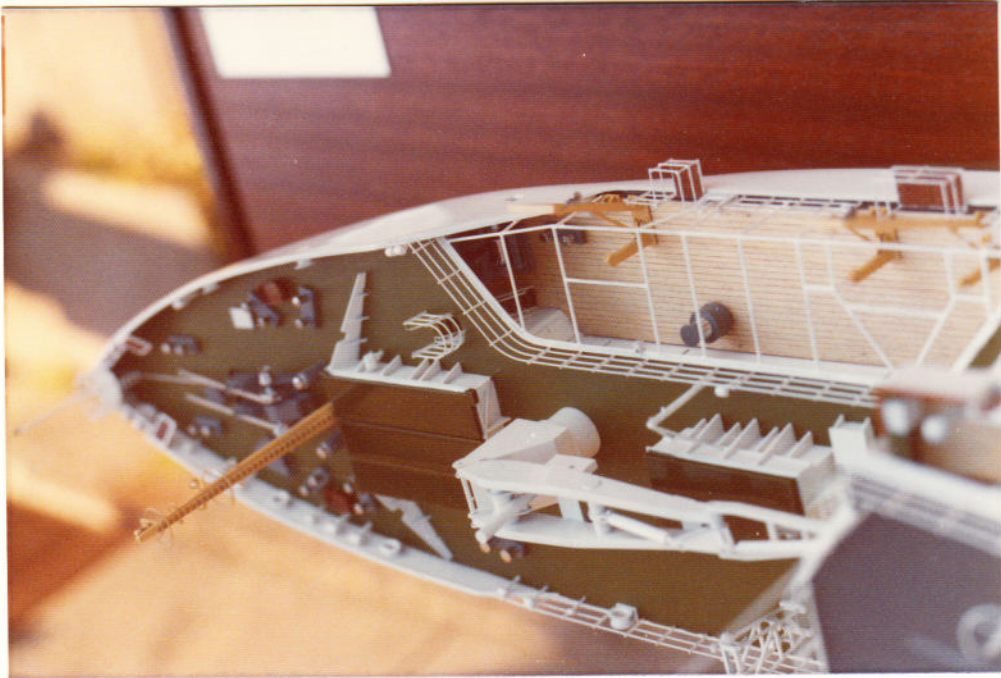



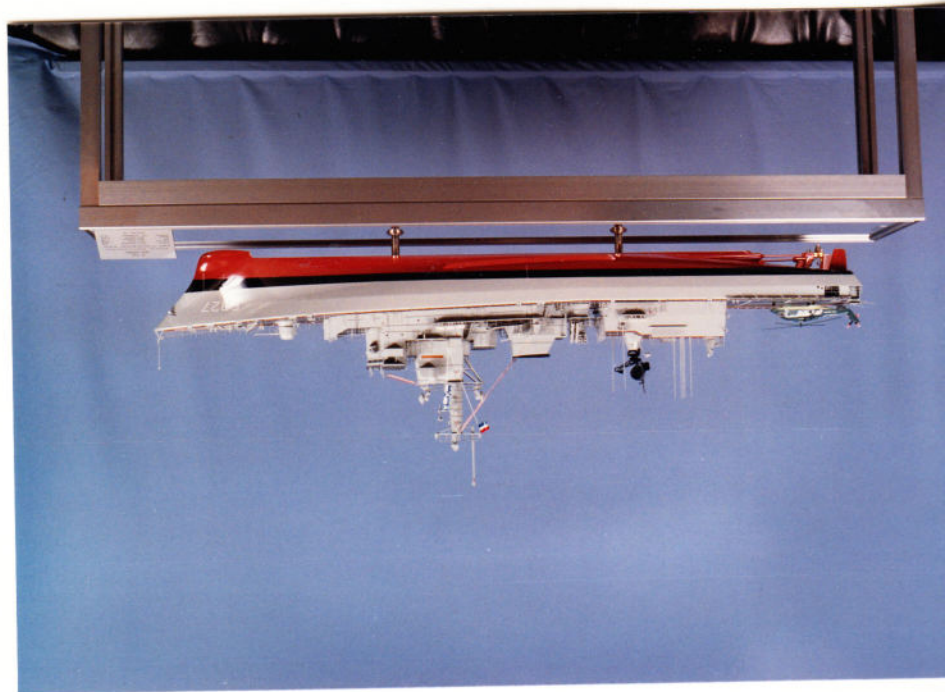
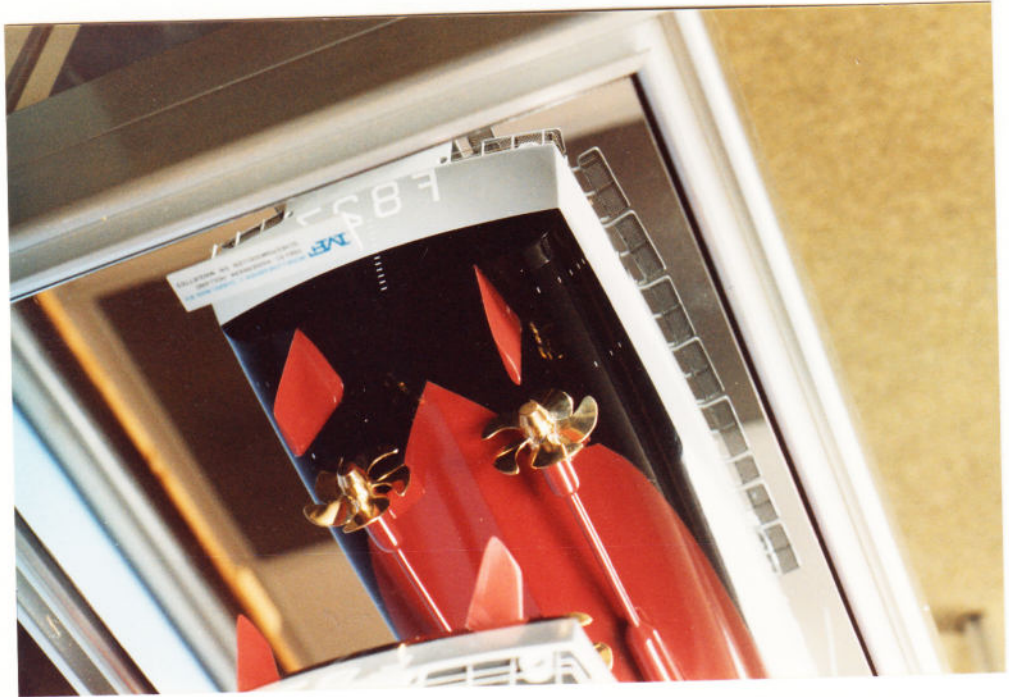

M. Fregat "Karel Doorman"
 Kon. Marine -
 2x 1:100
 (incl. tafel o-kiel).
 1e 18-4-88
 2e 10-5-88
 totaal. 880 uur.



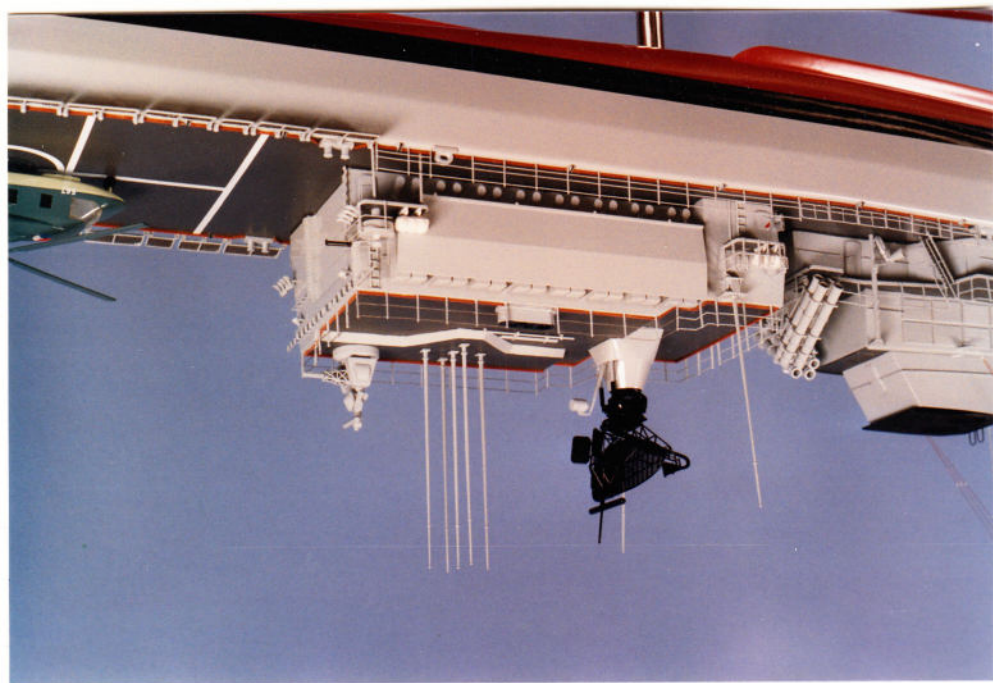
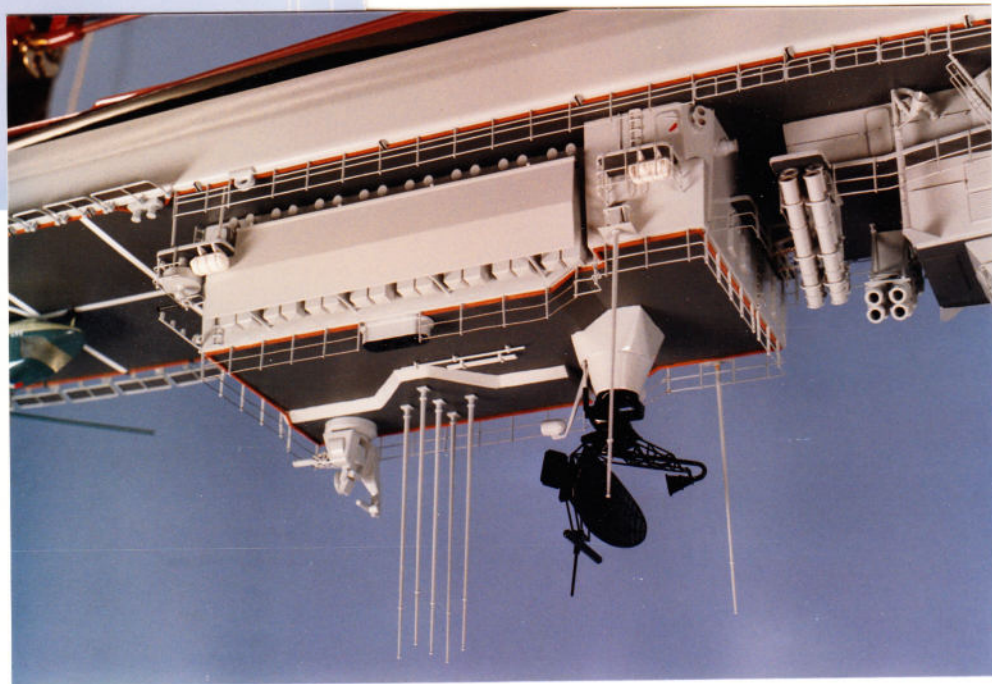
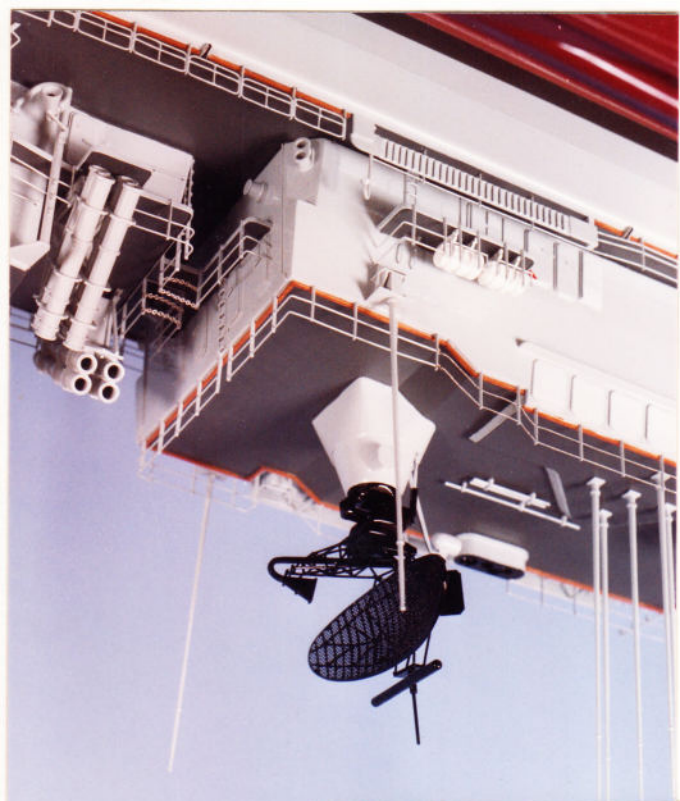

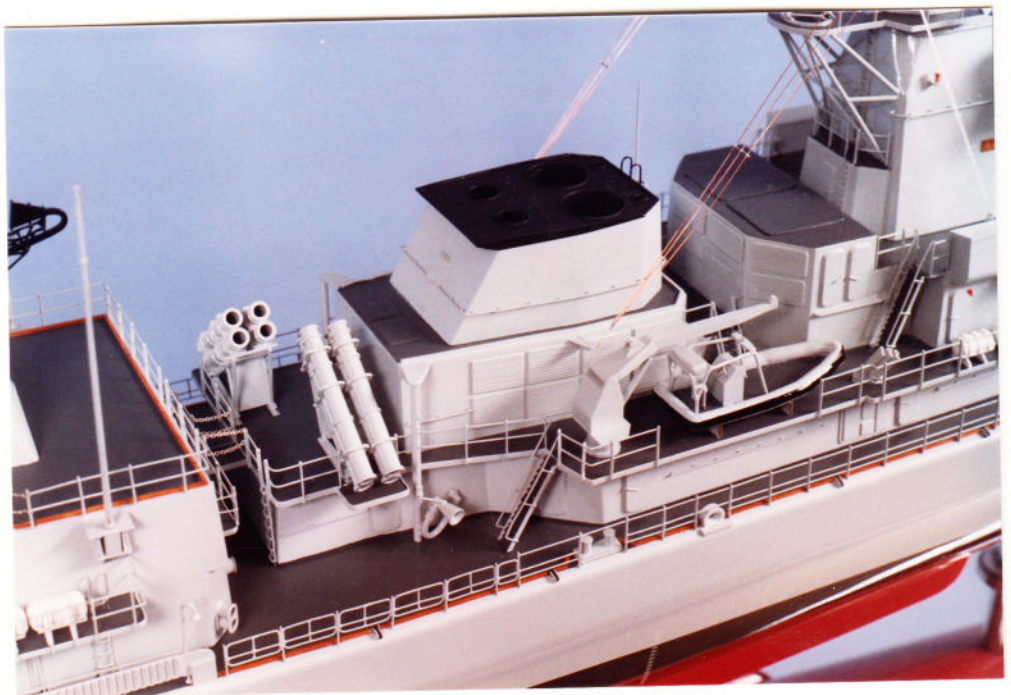
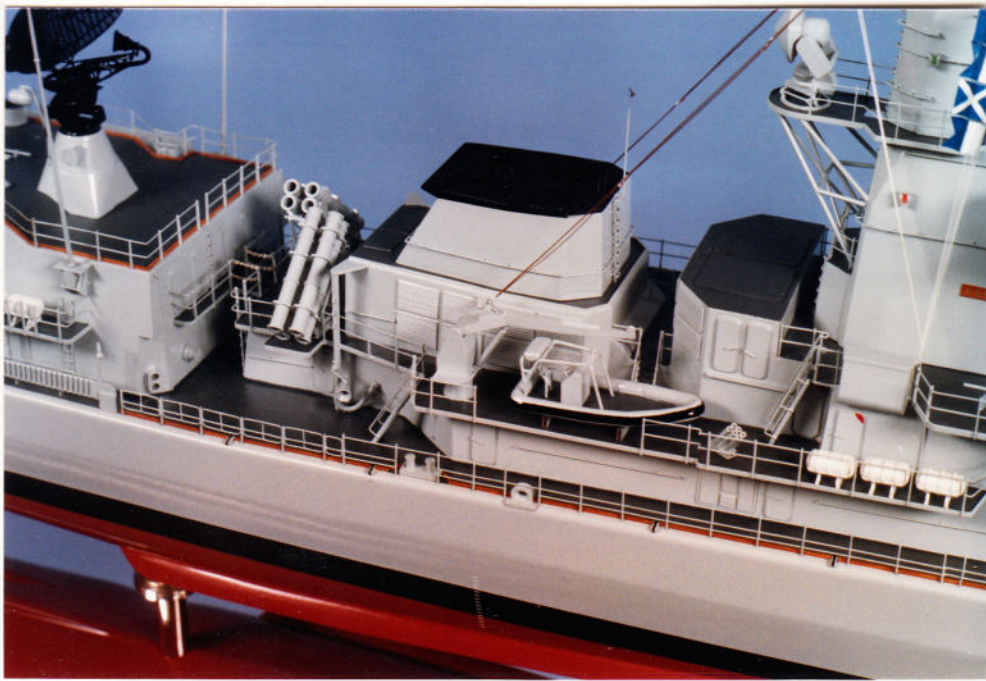

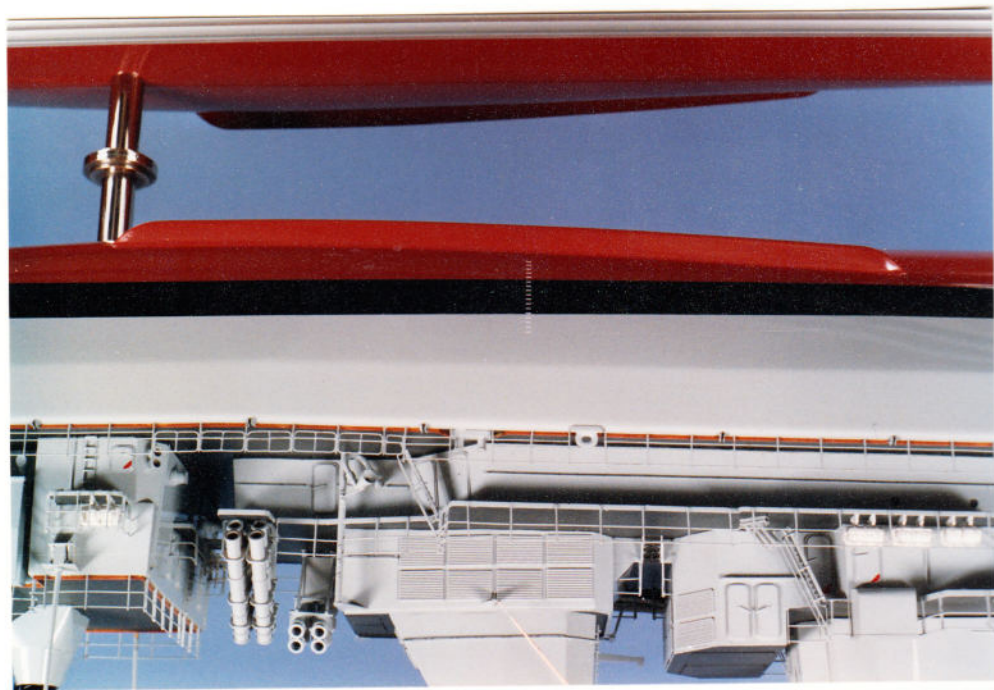
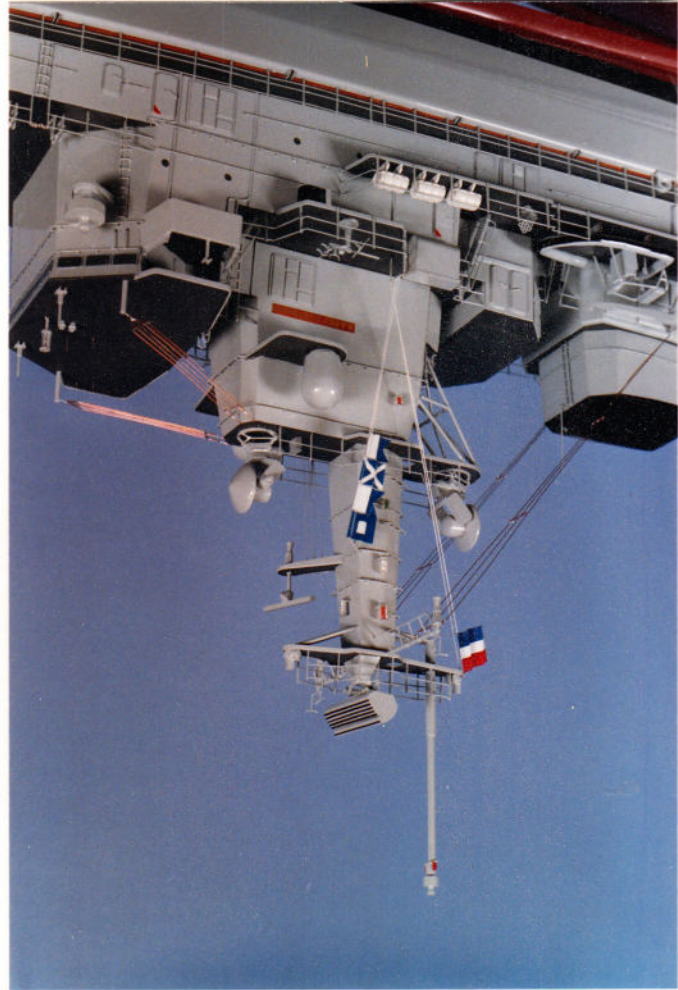
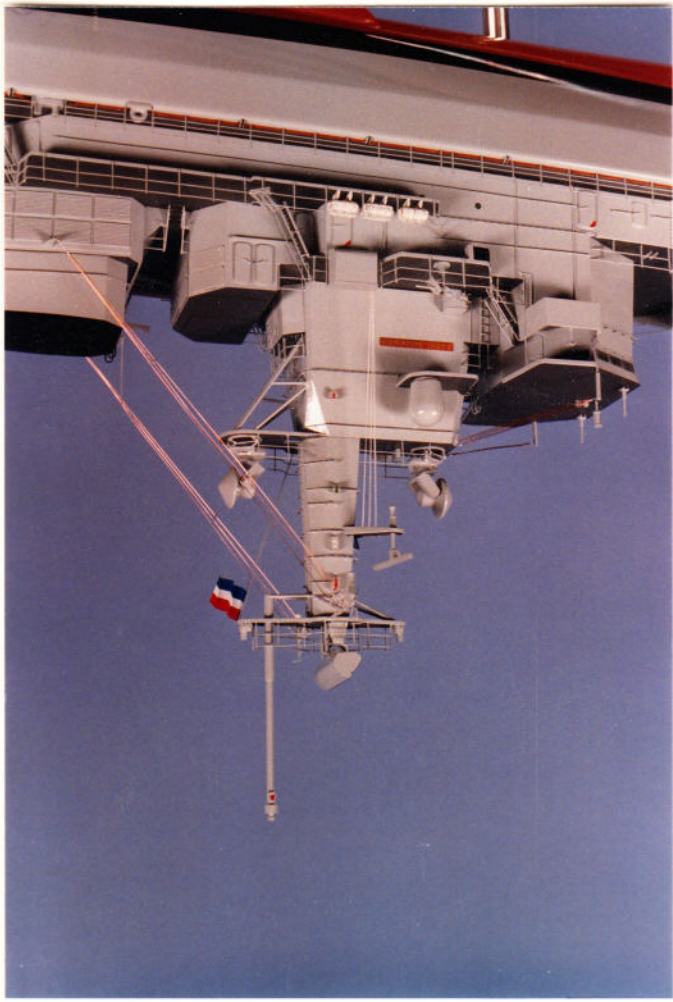



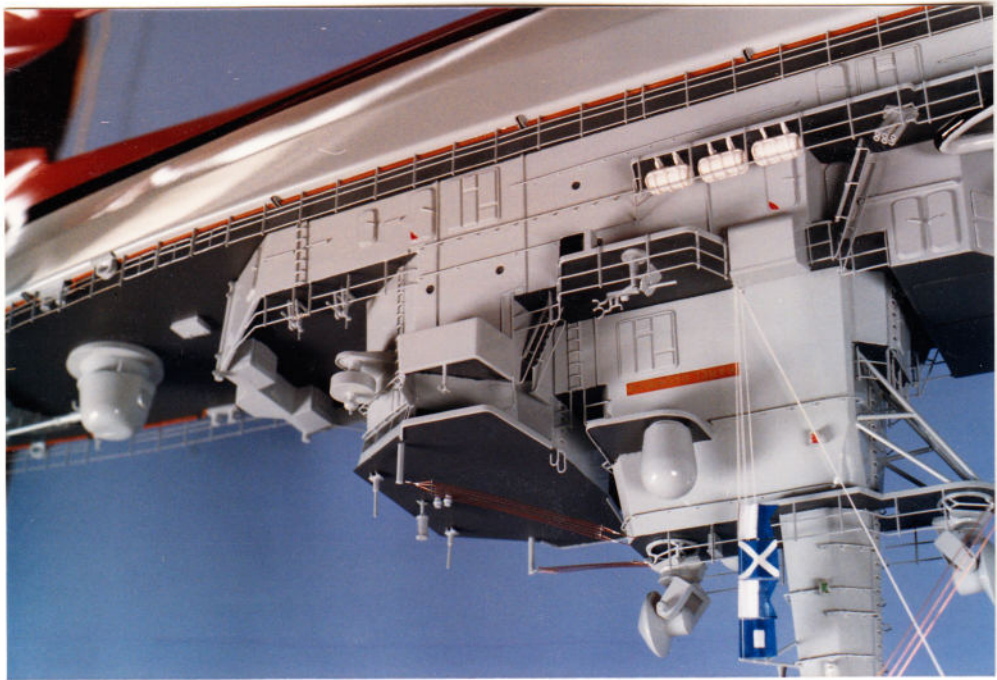
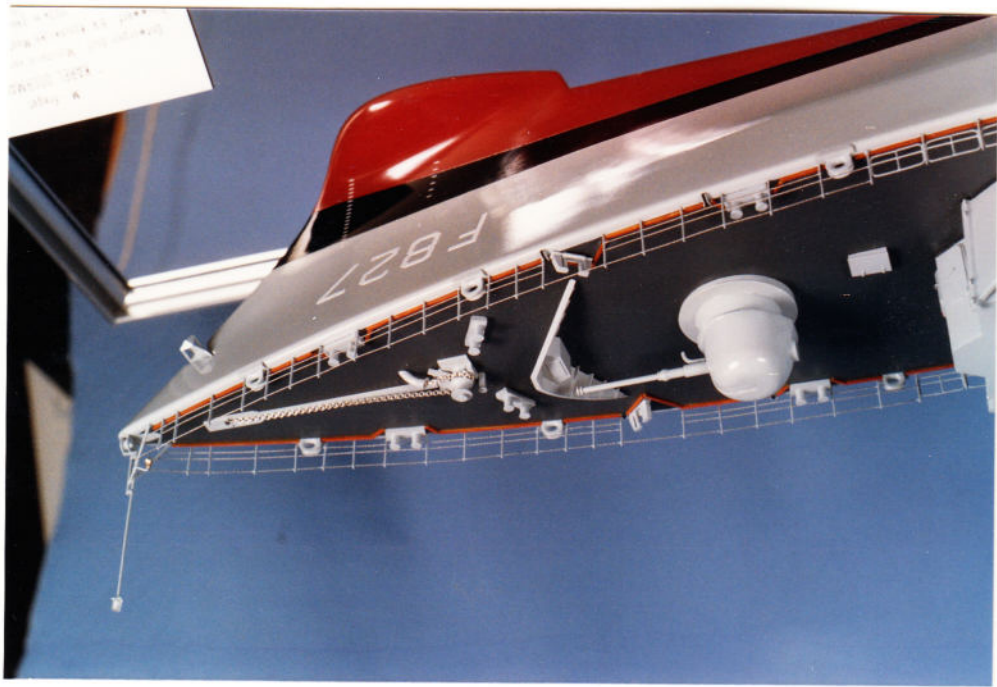
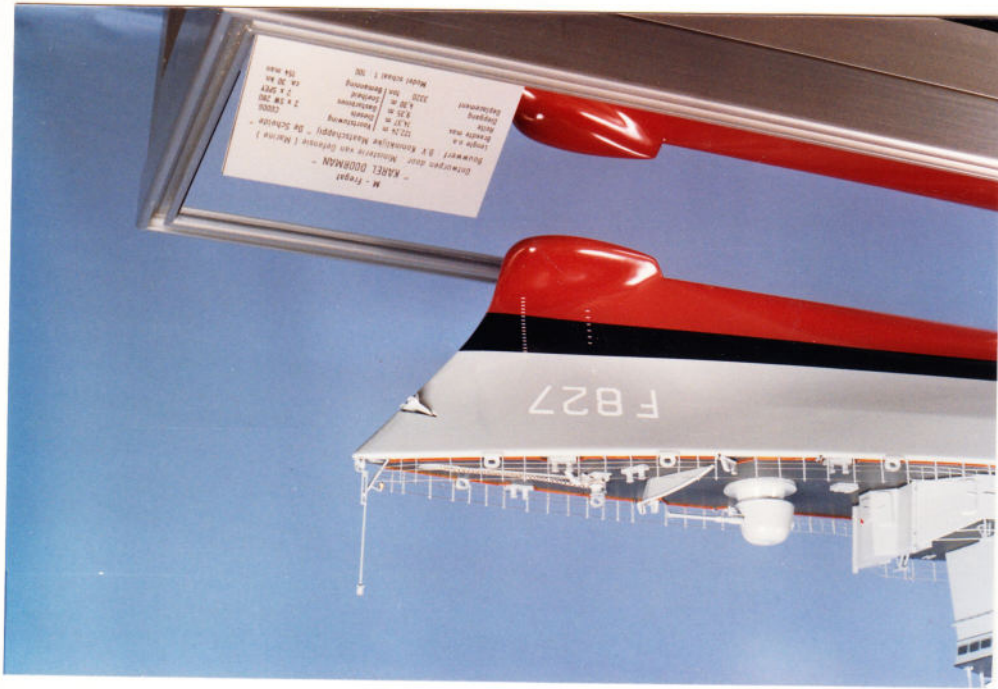

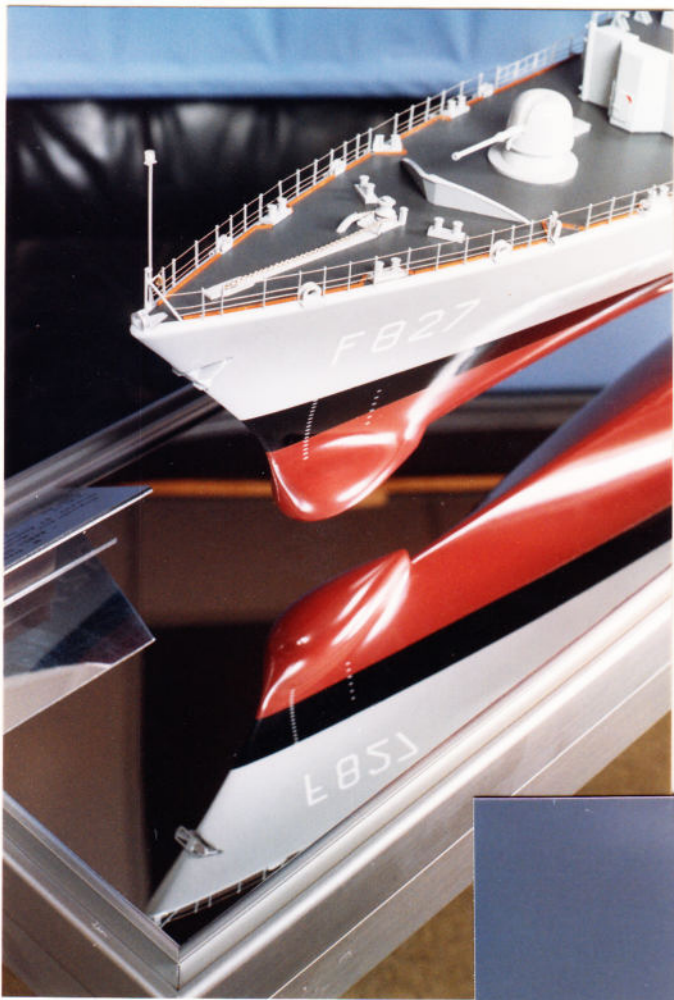

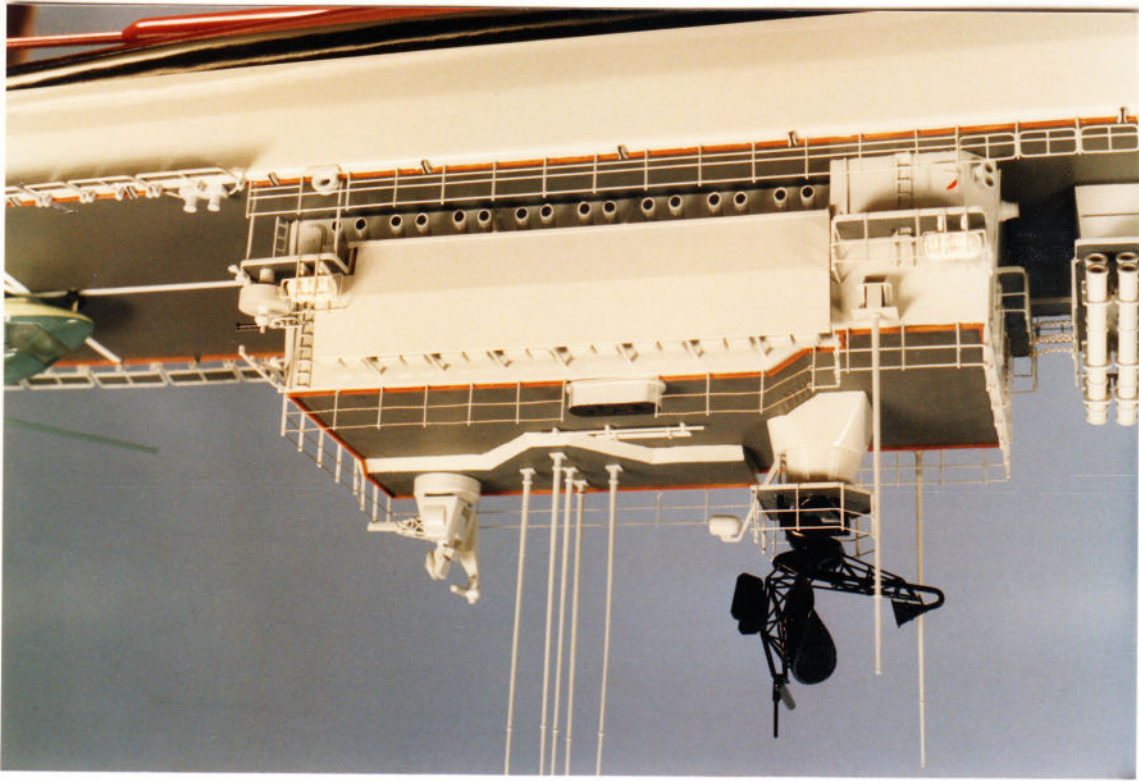

beoordelingen 2e model.
 geel heli copter.
 helde markering
 bordes onder radar.
 zwarte cilinder
 kippende op dek.
 sceneriewerk by reddingstronnel



Seopterwork by vedding-tromuets

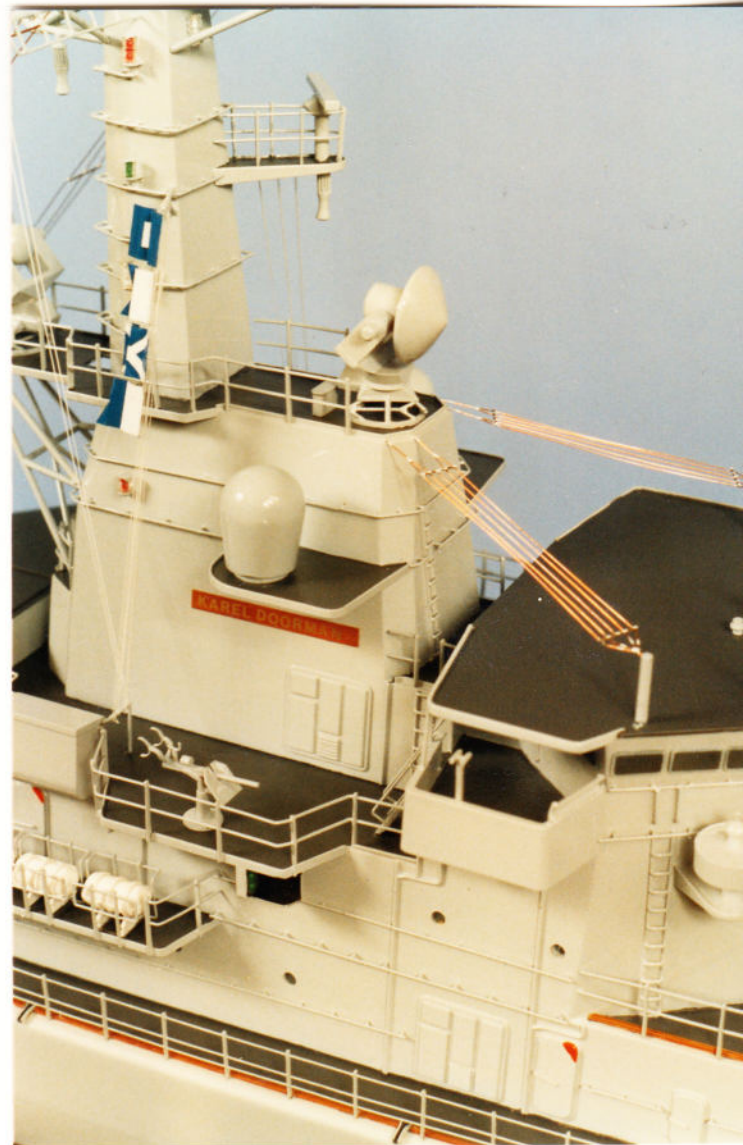

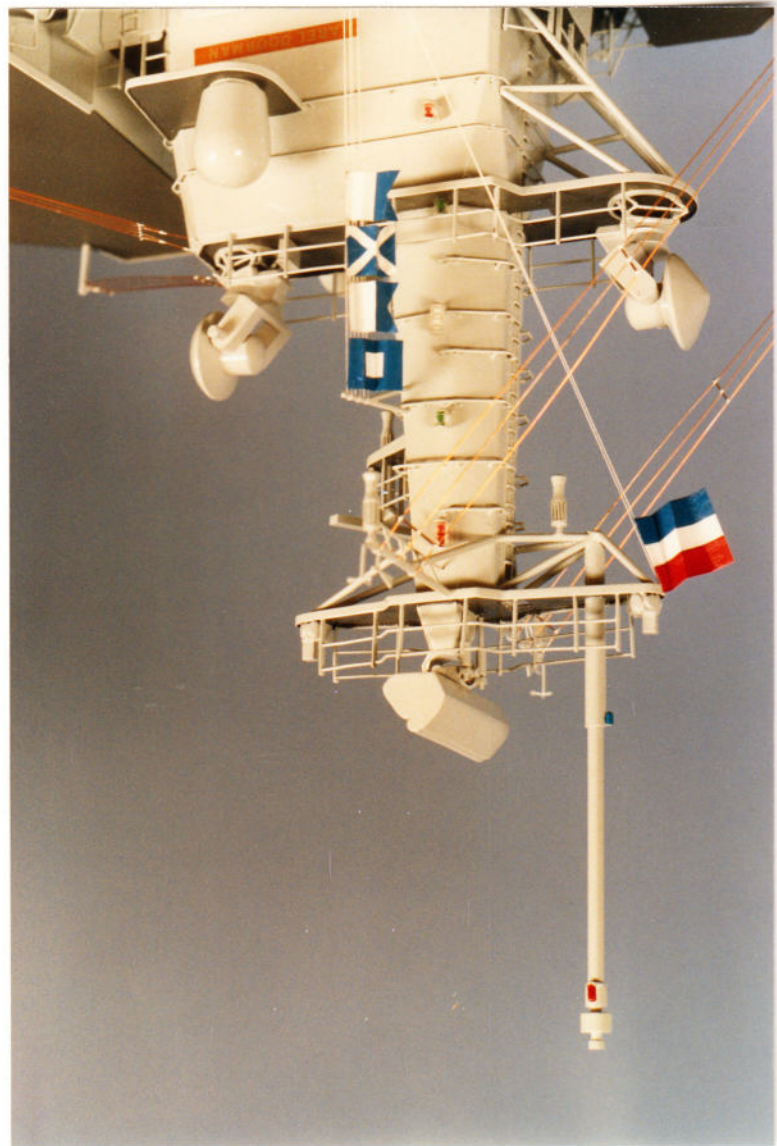

gear struts on top nodes.
 andere sleep draft.
 wijziging sectormat by sleep.

VAN RIETSCHOTEN & HOUWENS
1:100

BEWEEGBARE MODEL
VOOR WERKING STABILISER

10/8/90

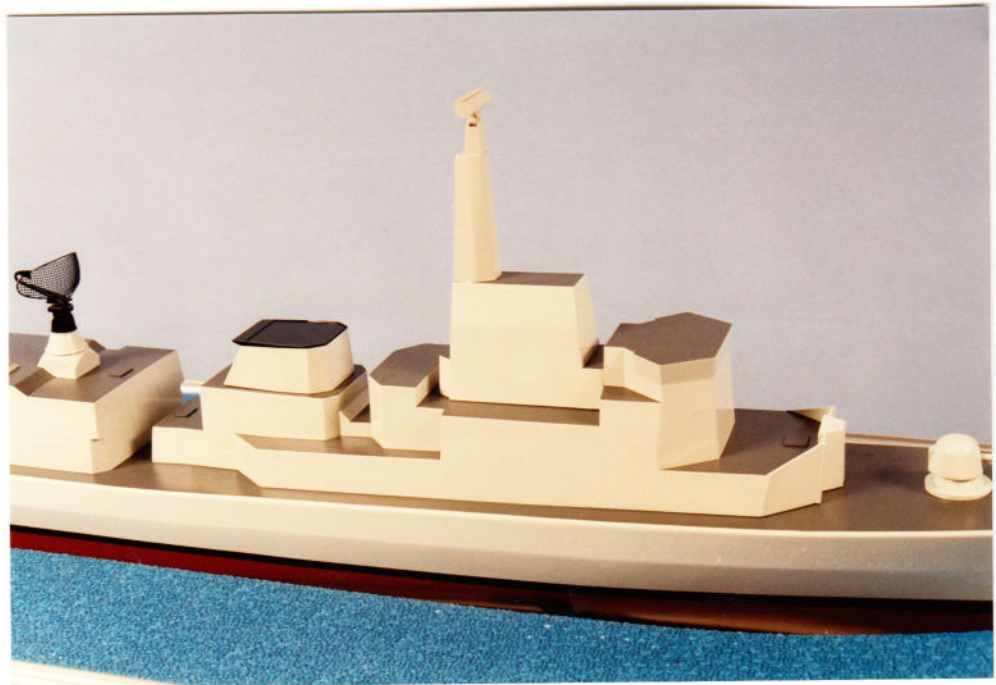
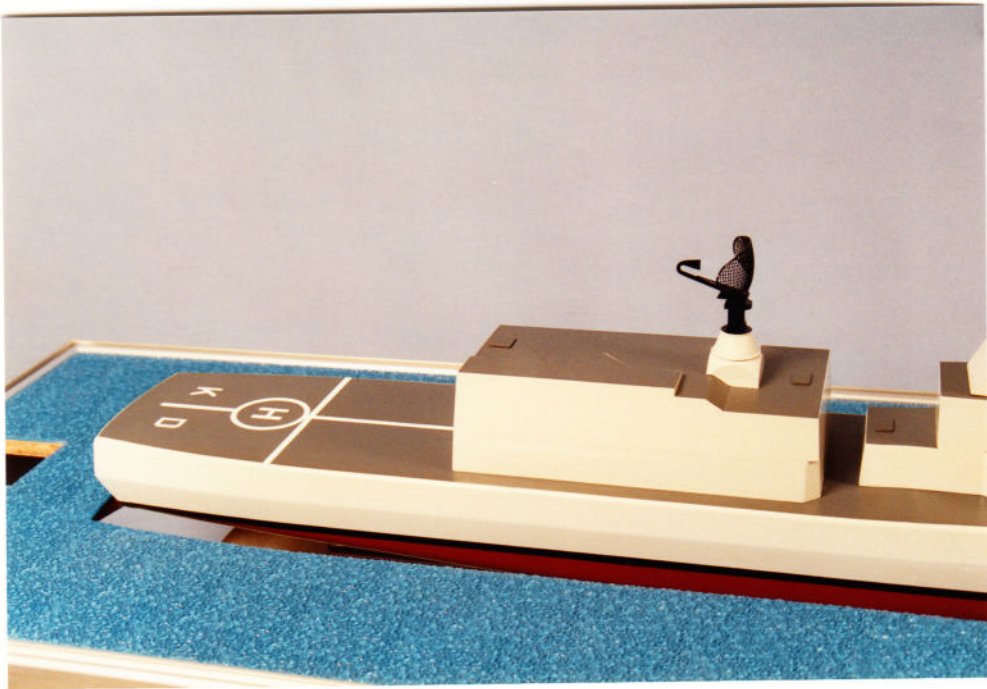
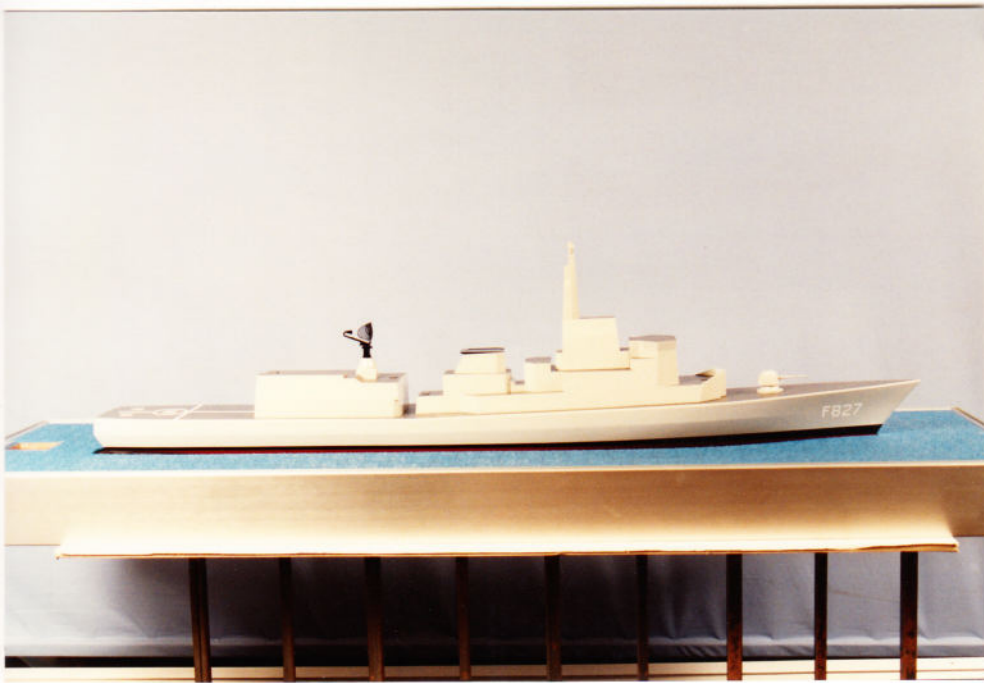

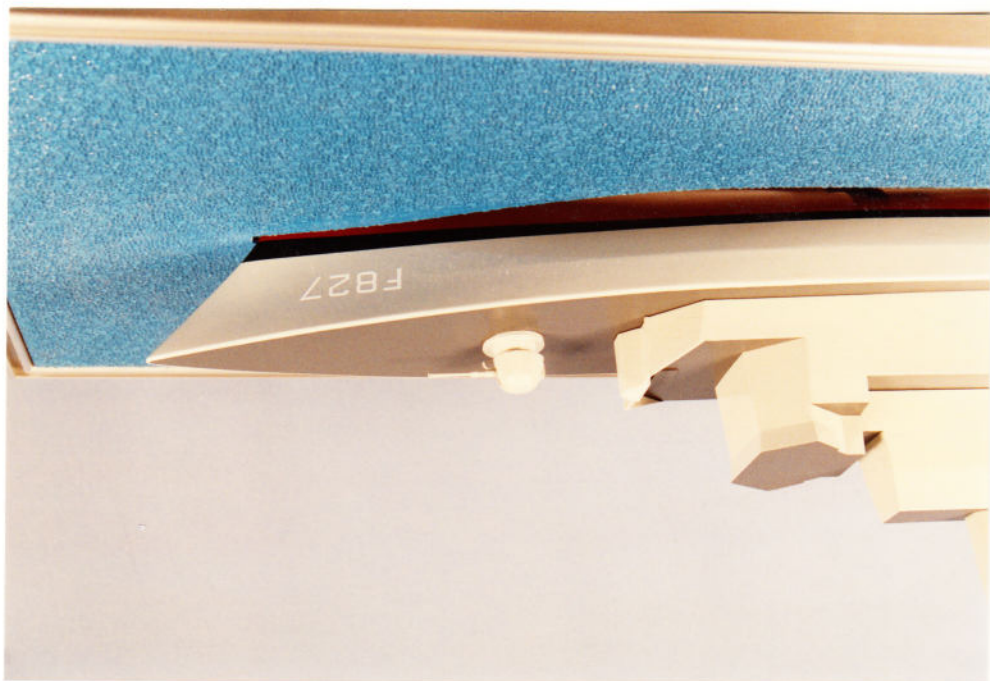



SCHELDE 2
+ HSA 1

LCF

1:100

1^o off. schelde 6/2

2^o " " 4/2

3^o " H.S.A. 13/6

tot. 771 mm.

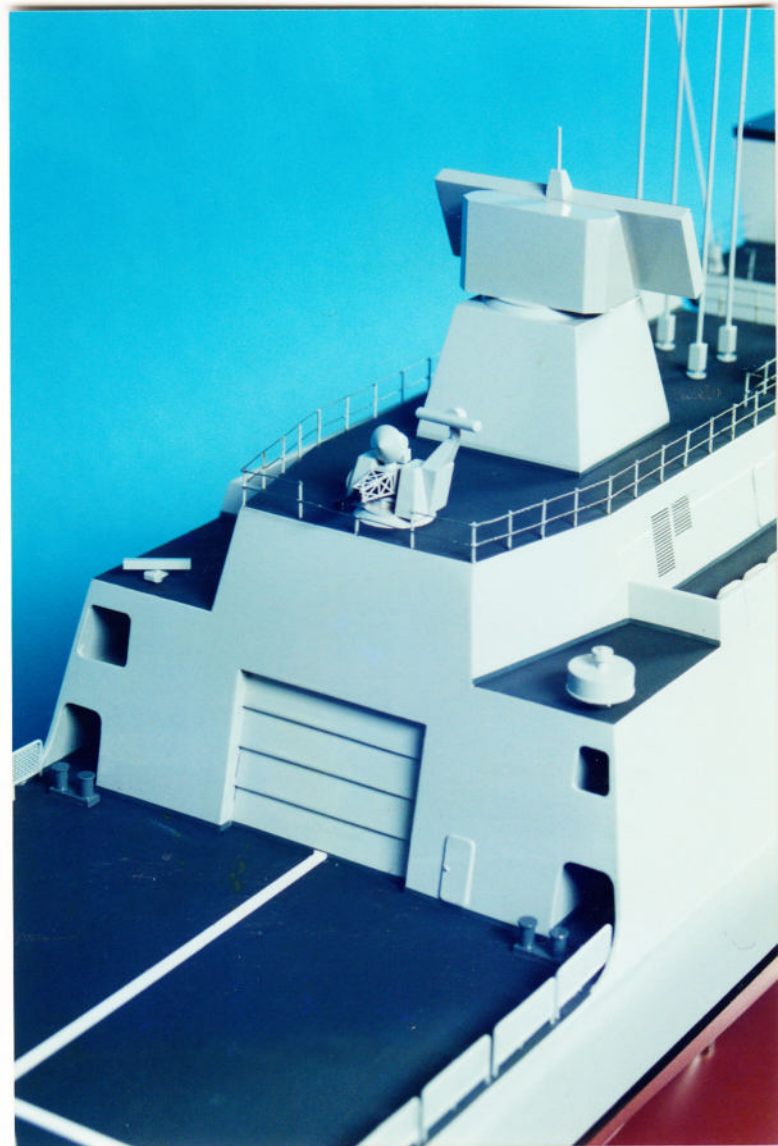

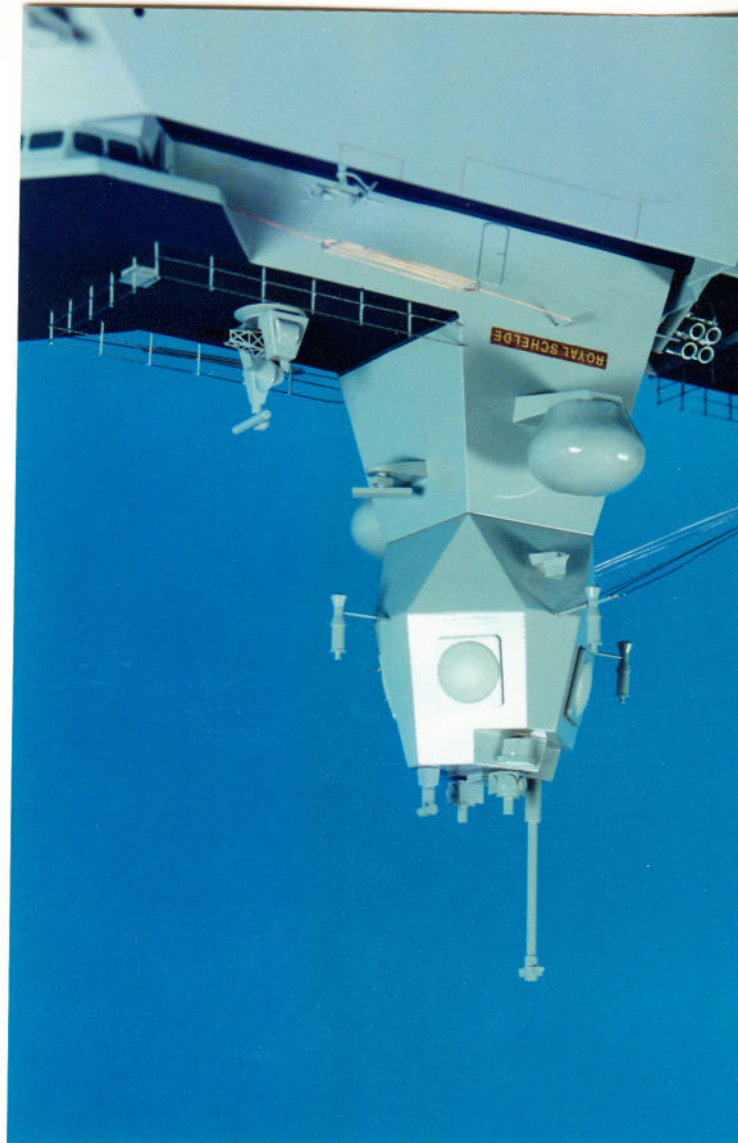
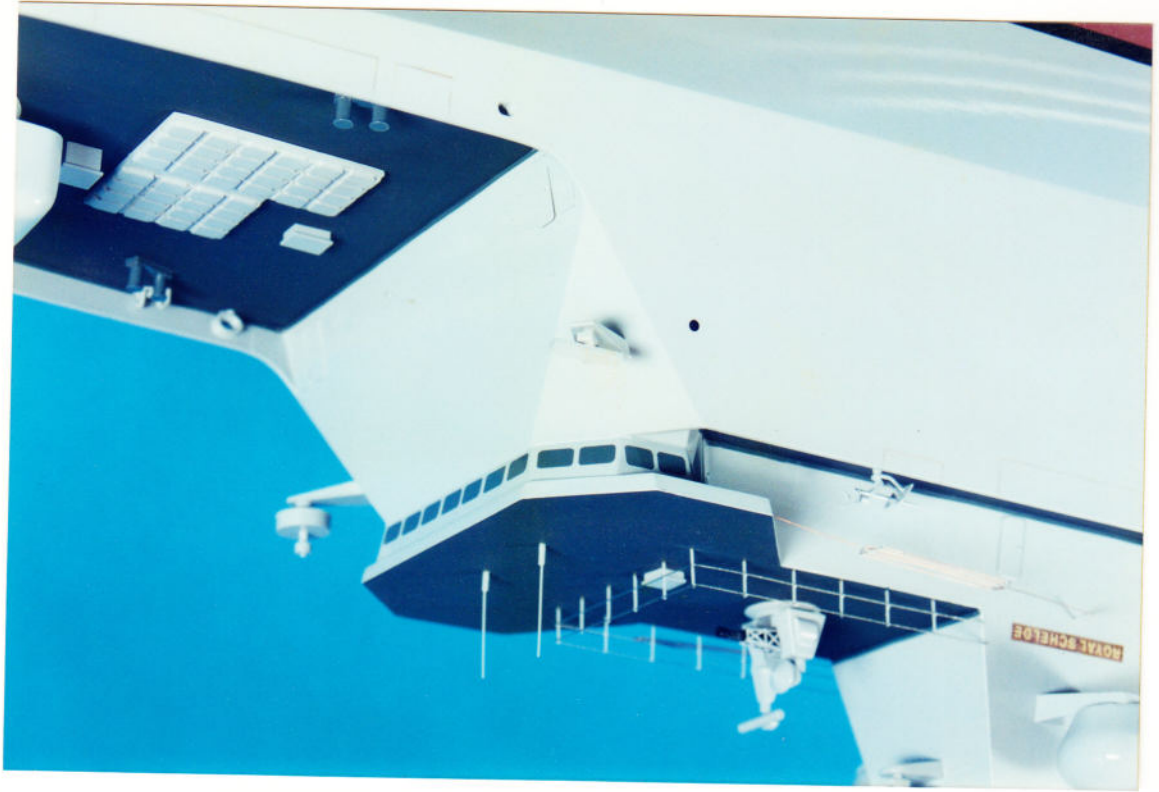

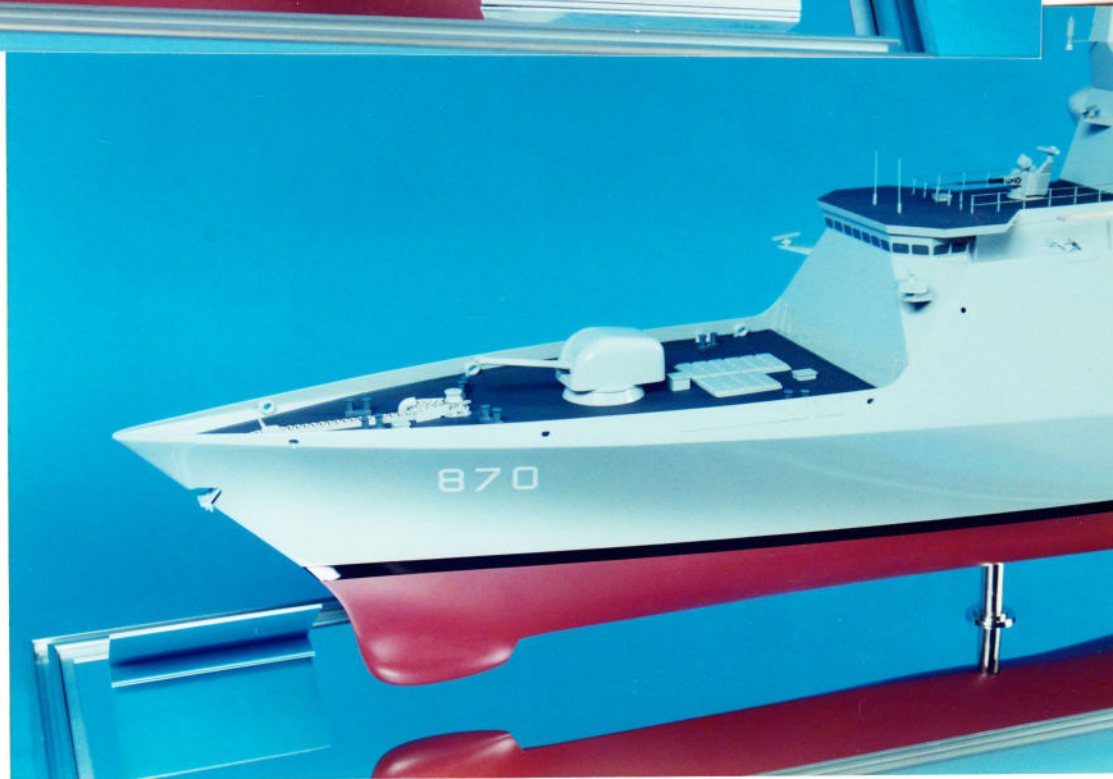



SCHULDE on H.S.N.

11/6/96

13/6/96

4
draaiend
radar.

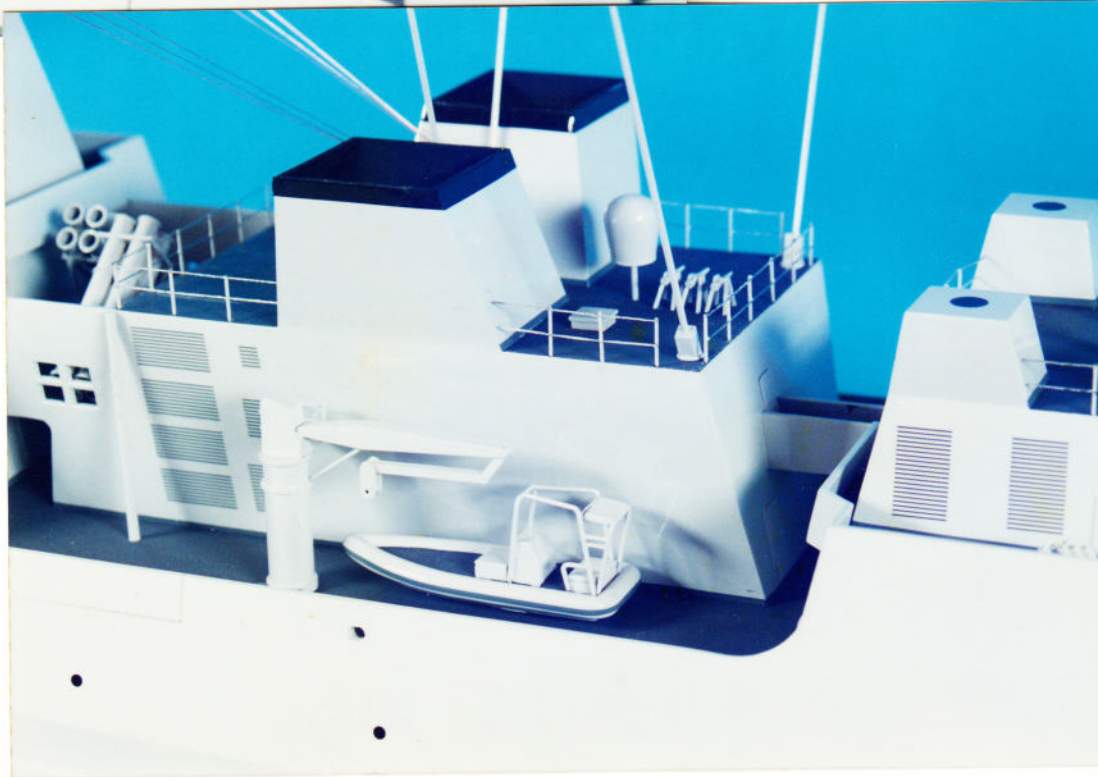
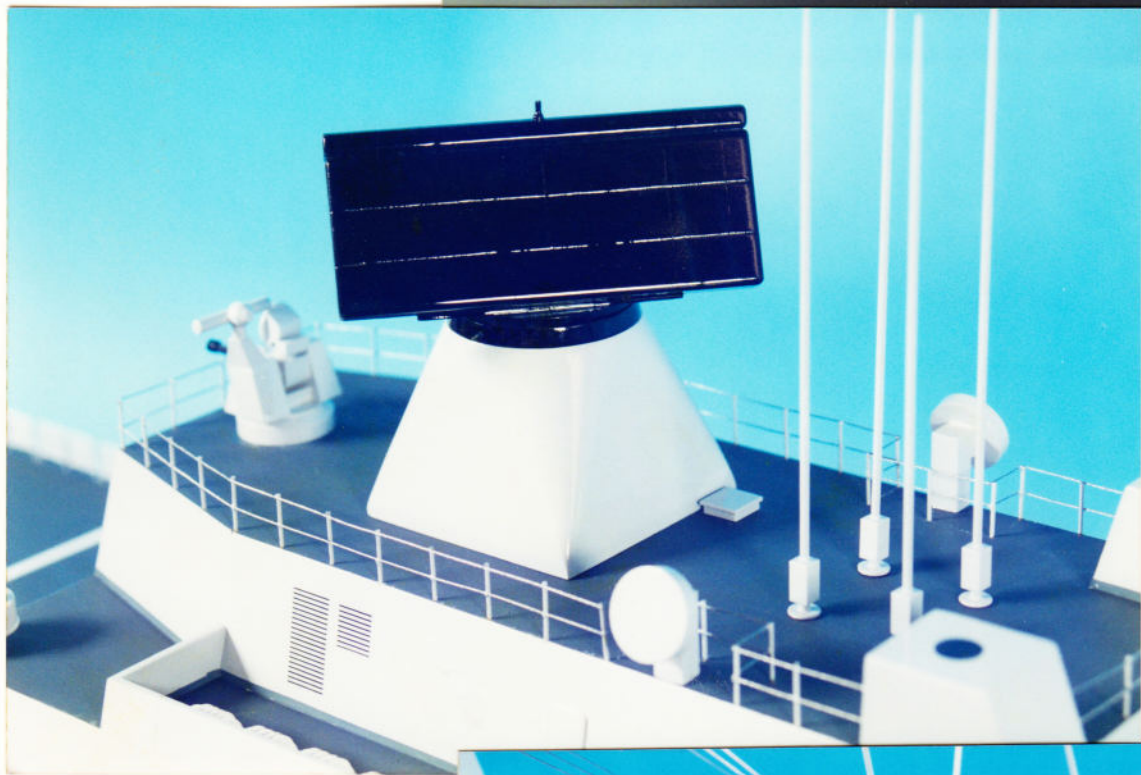

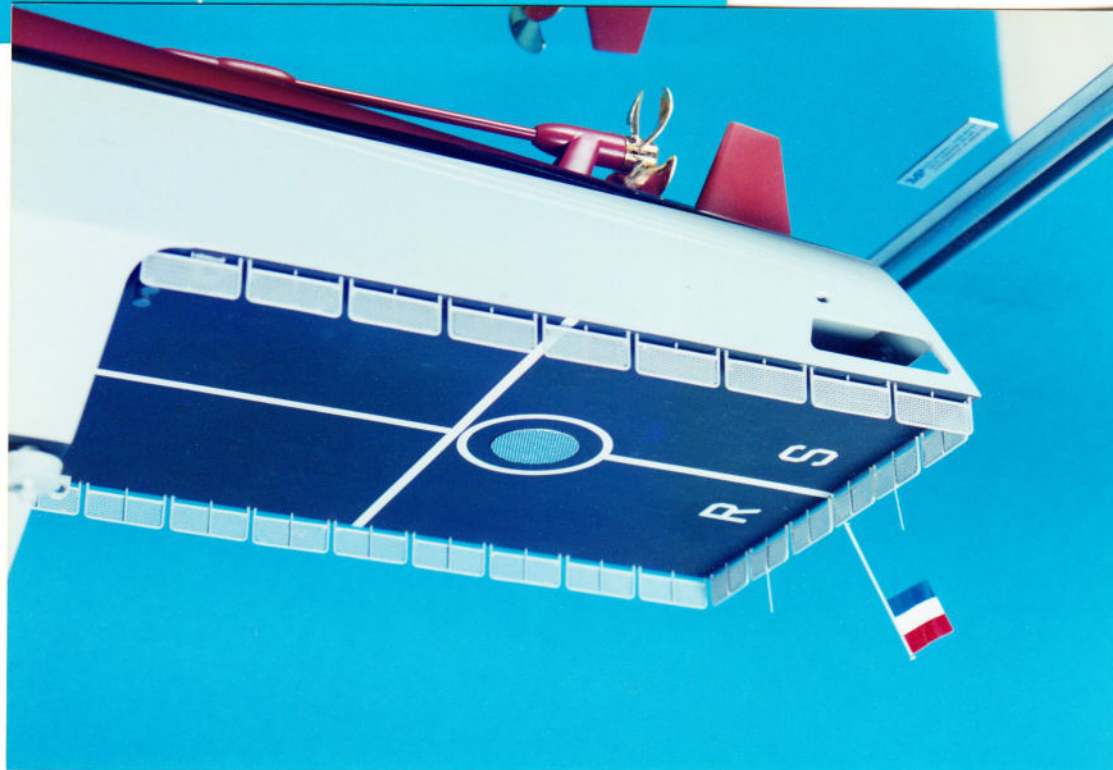
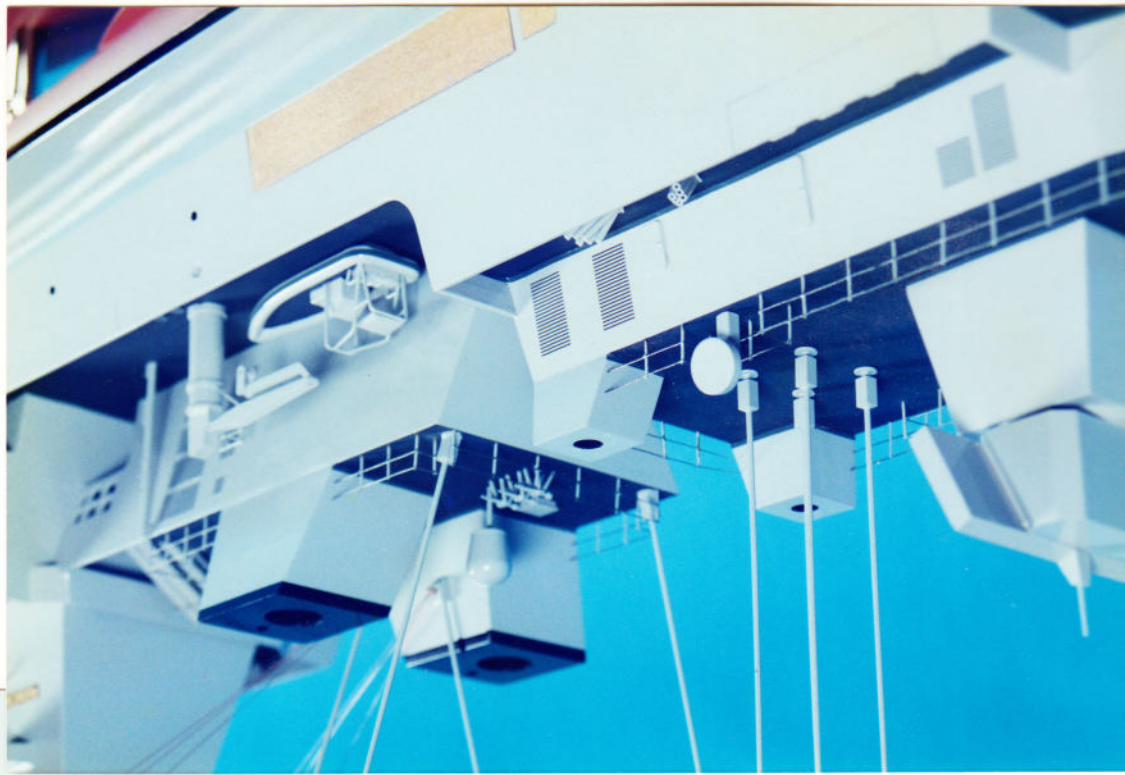

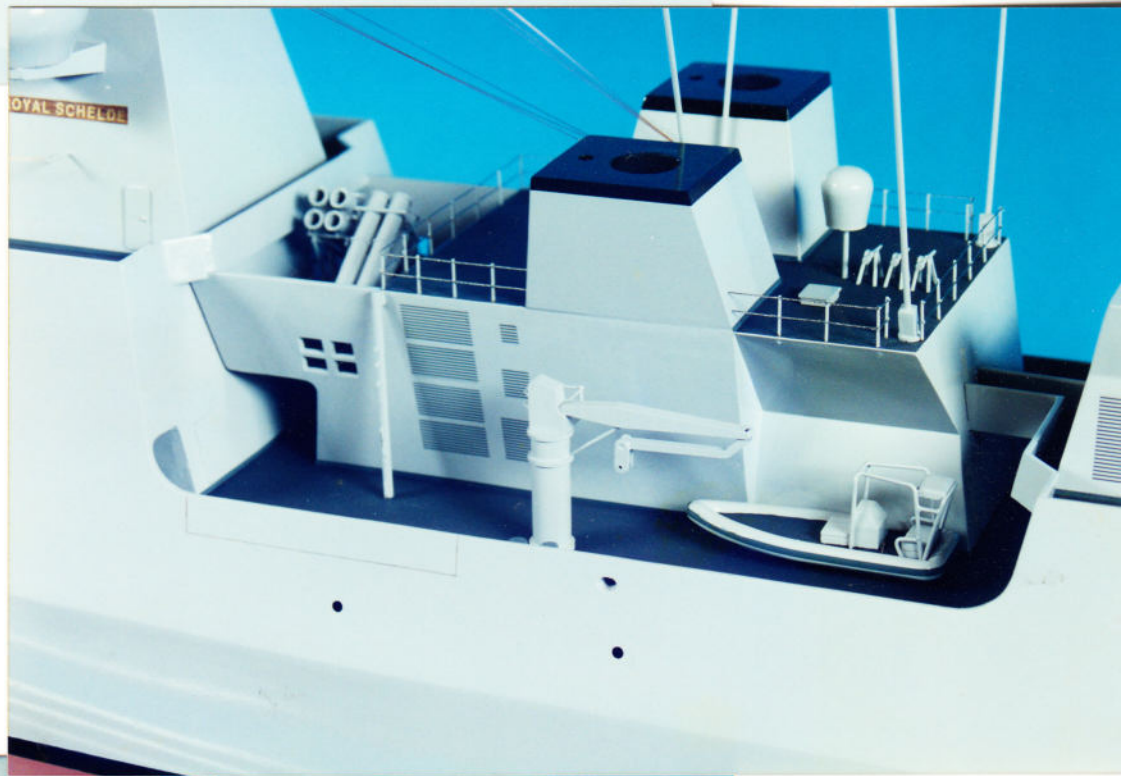
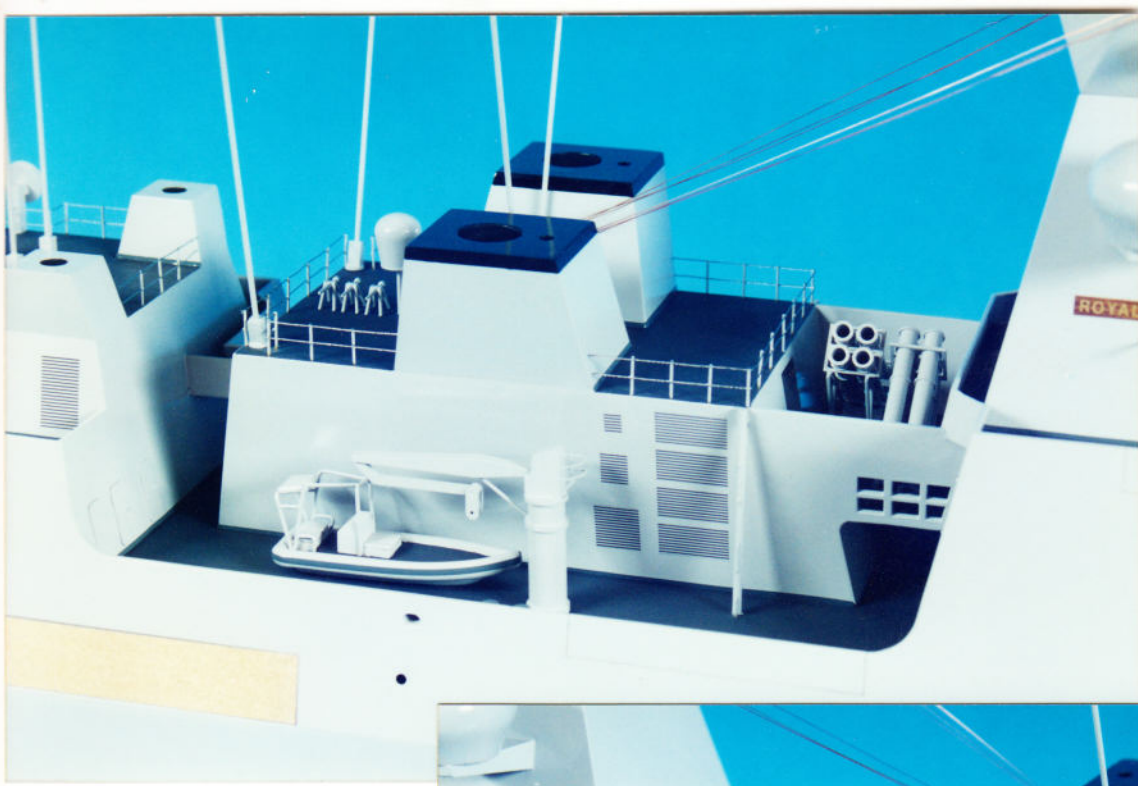





Gewyzigde kop 1-1-2001
voor H.S.A.

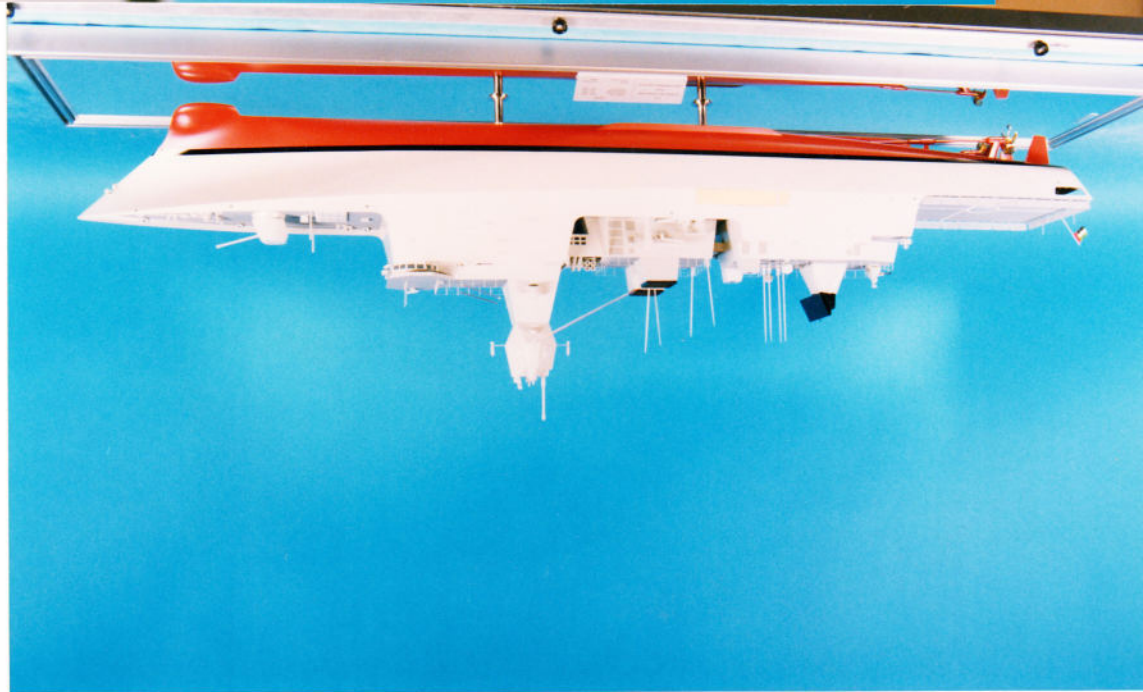
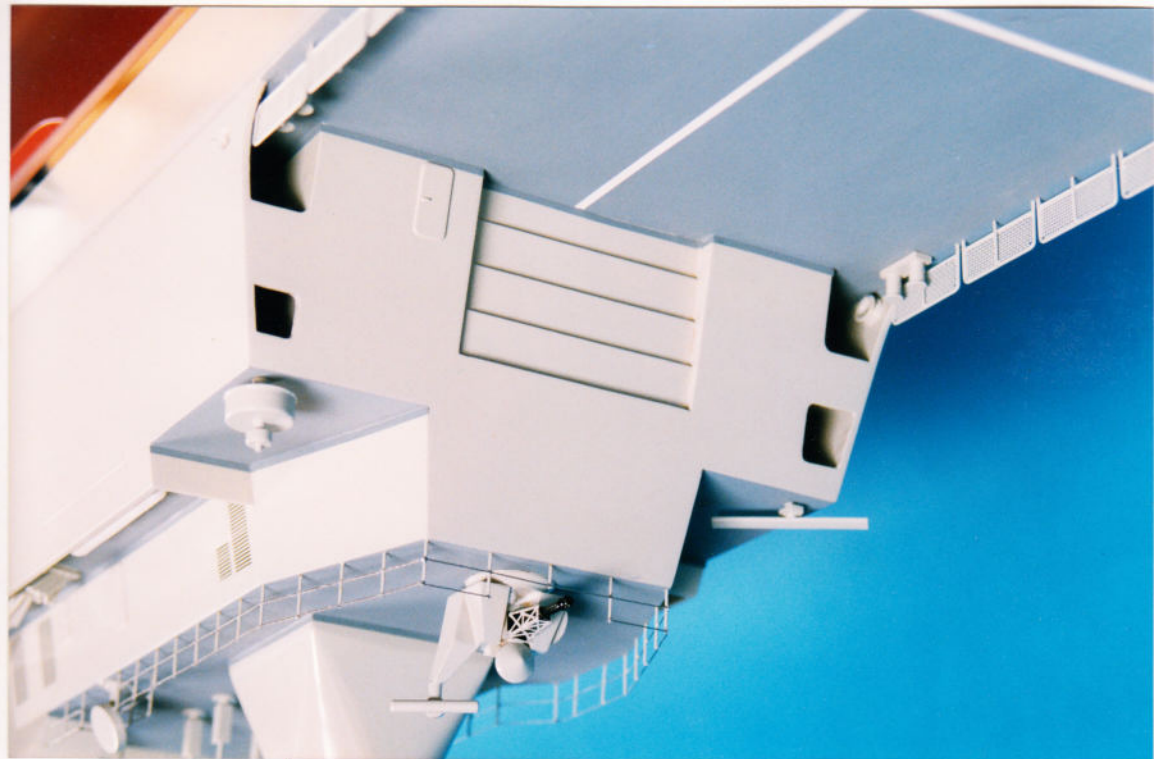

DE SCHEDE
 8 Jun 1996
 L.C.F. fraggot
 1:100
 Door U.A.E.
 (andere kleuren)
 205 mm.

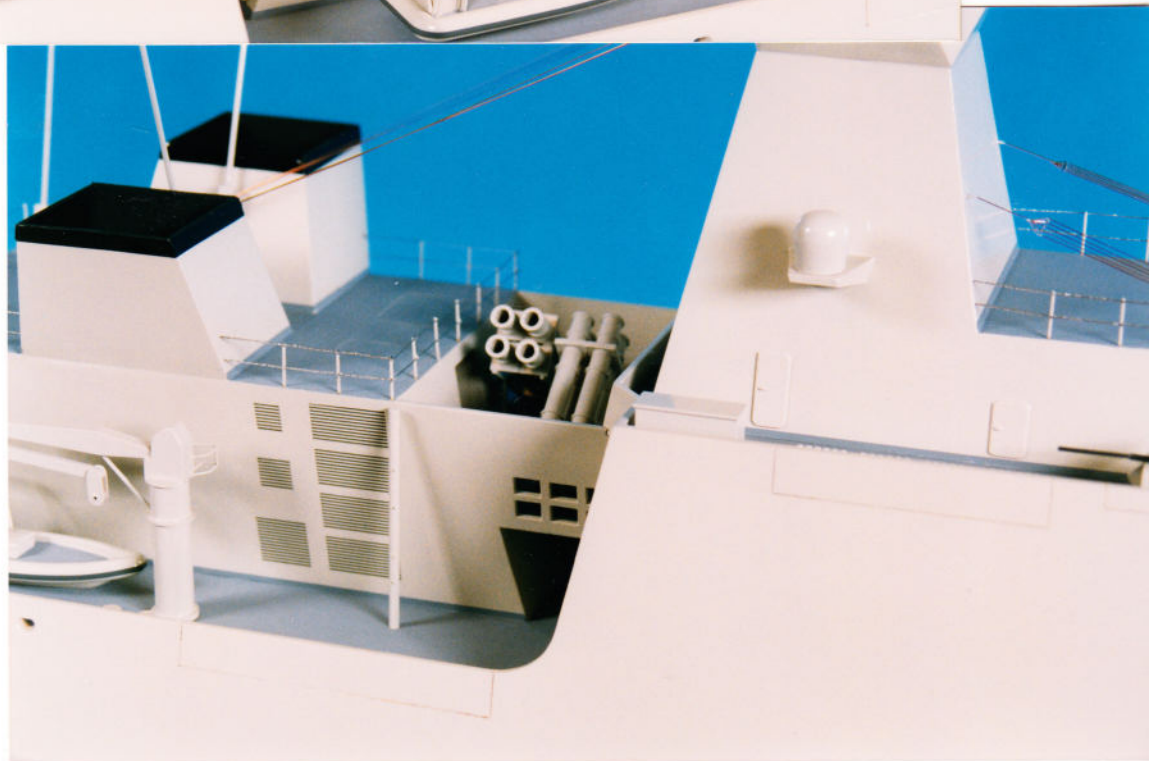
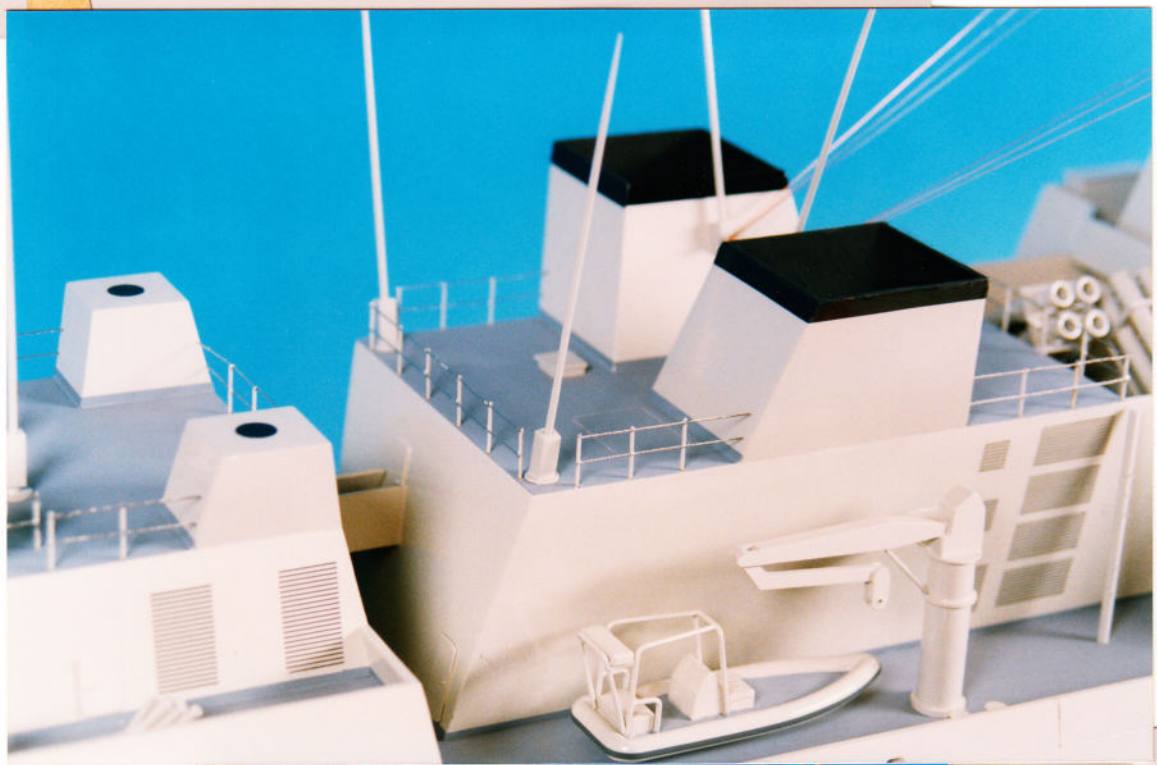

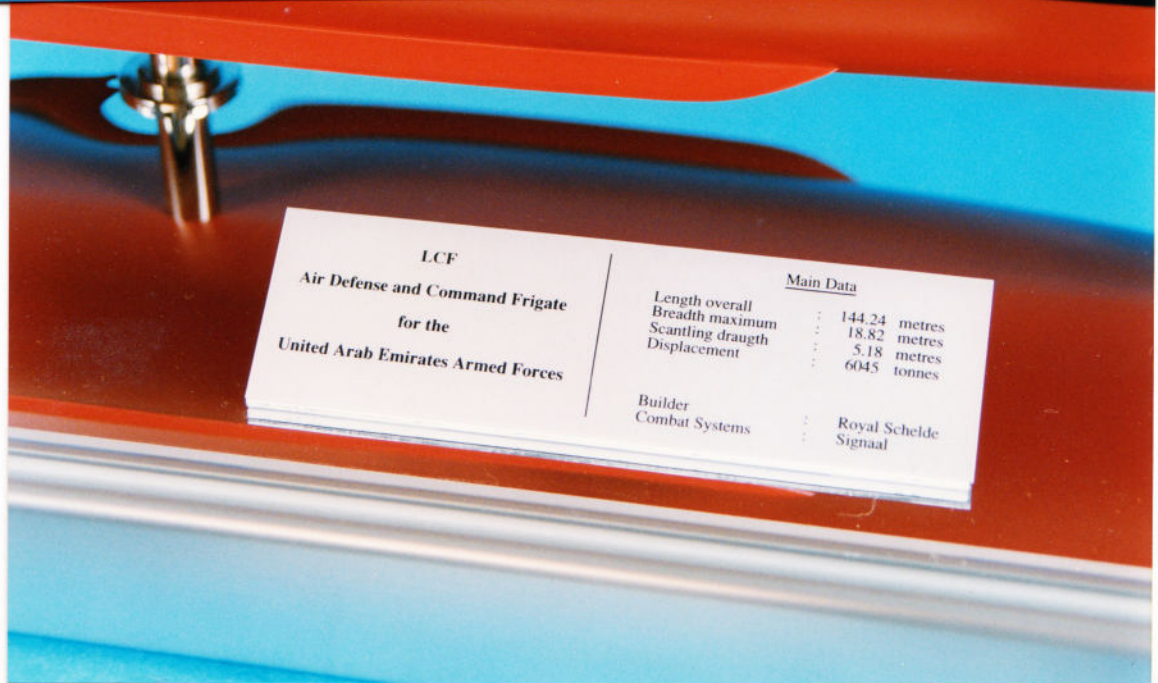
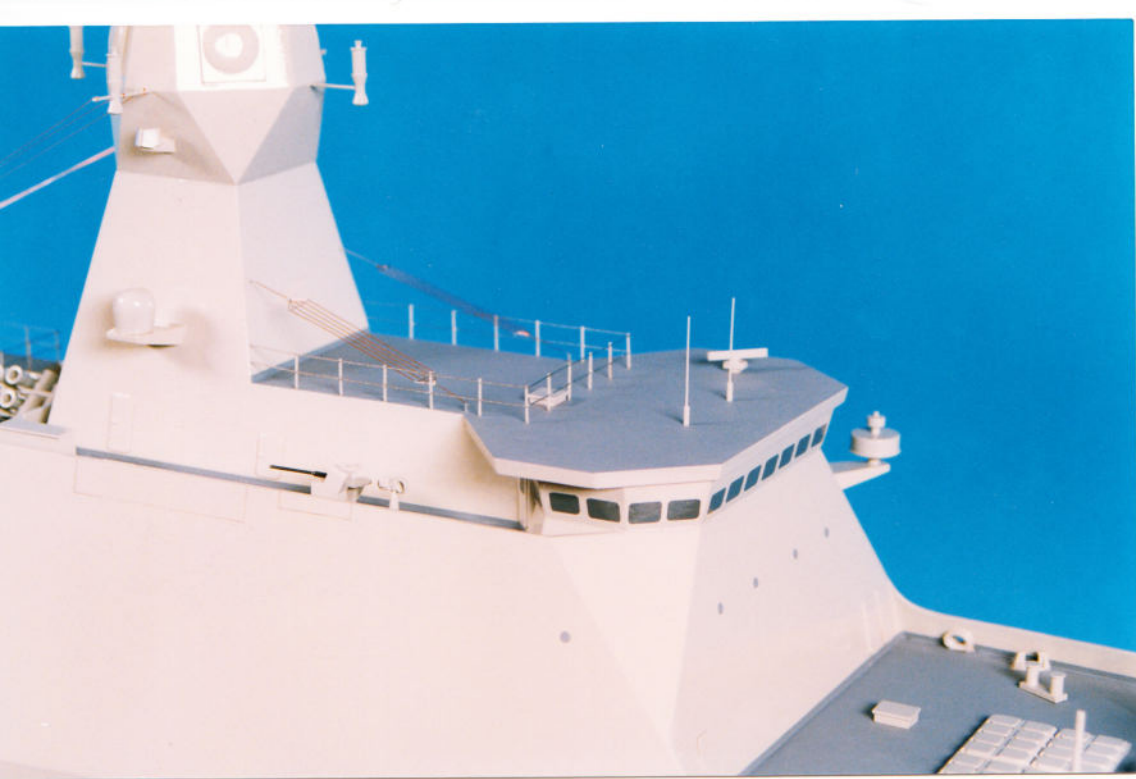

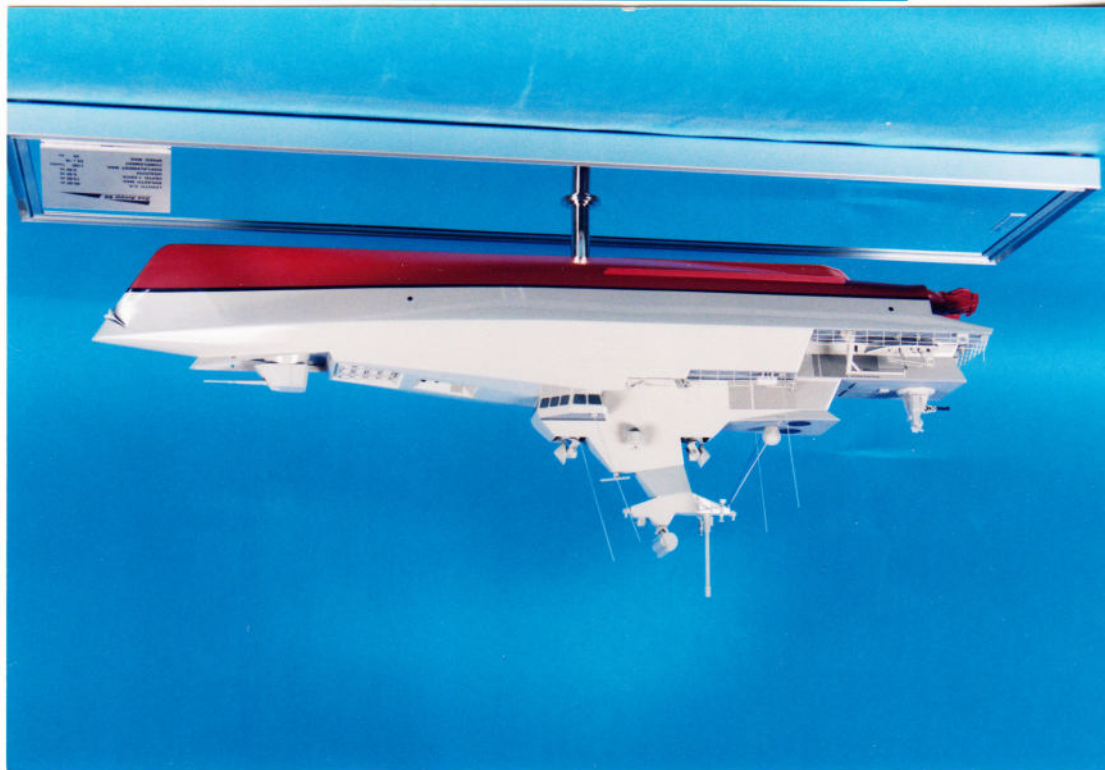
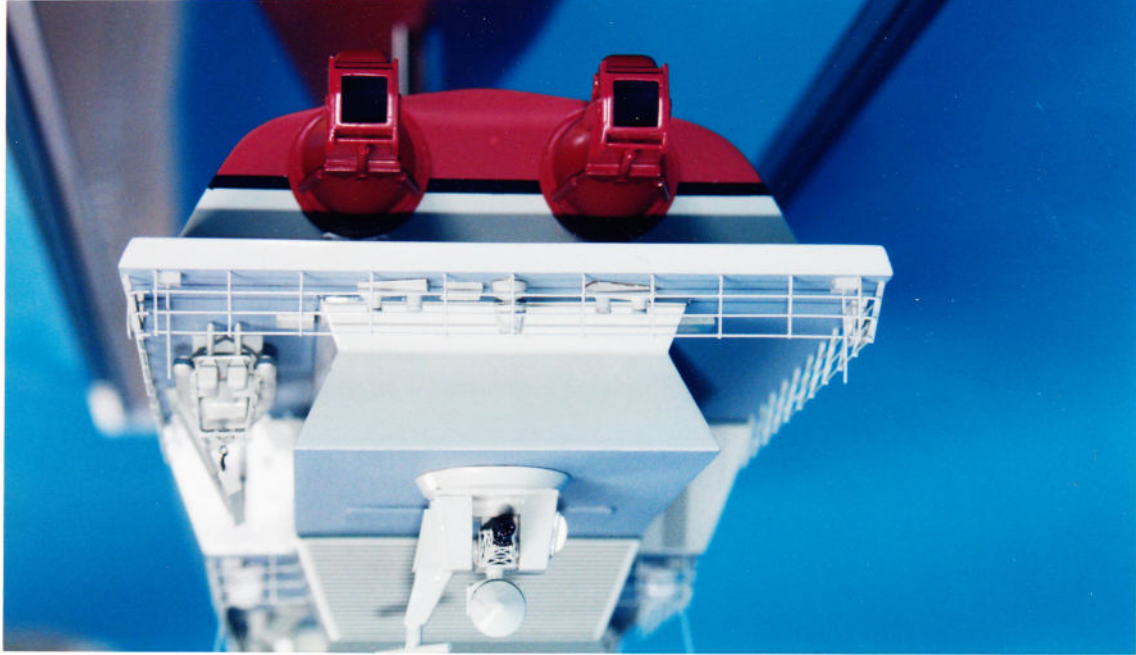
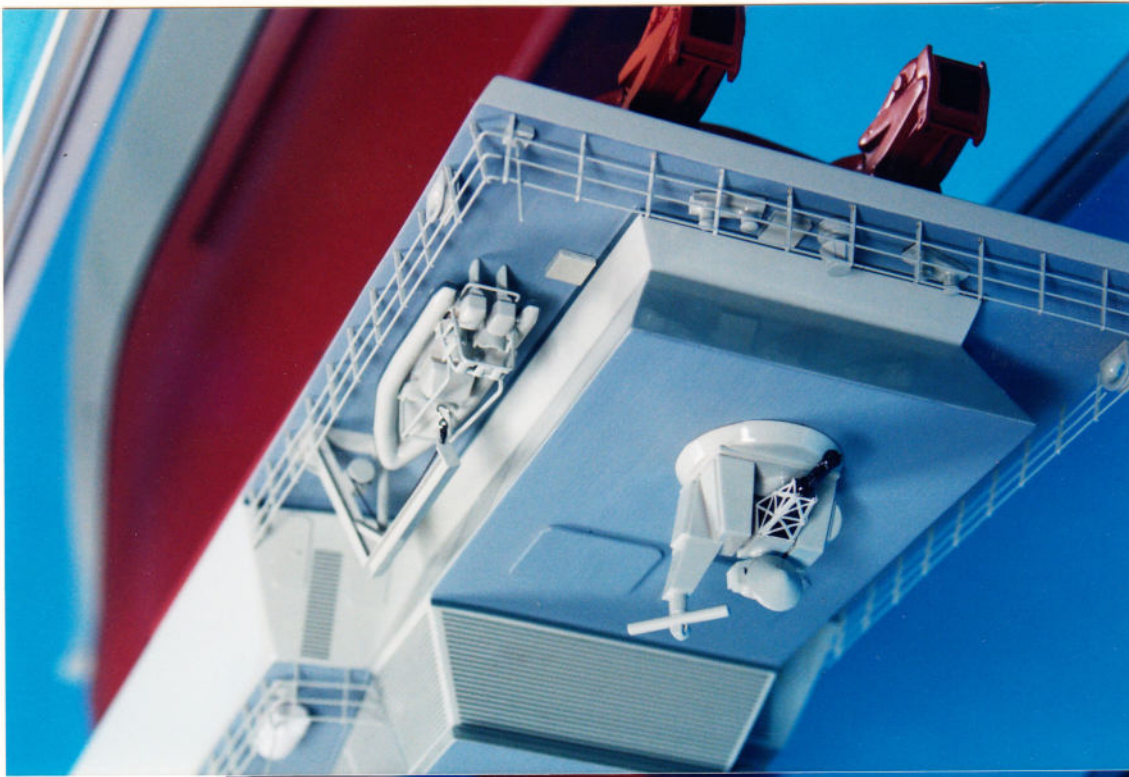

SCHELDE
SEA AREA
1:100
15/2/97.
289. ins.
(mit mod. Mast
(und mod. Schip))

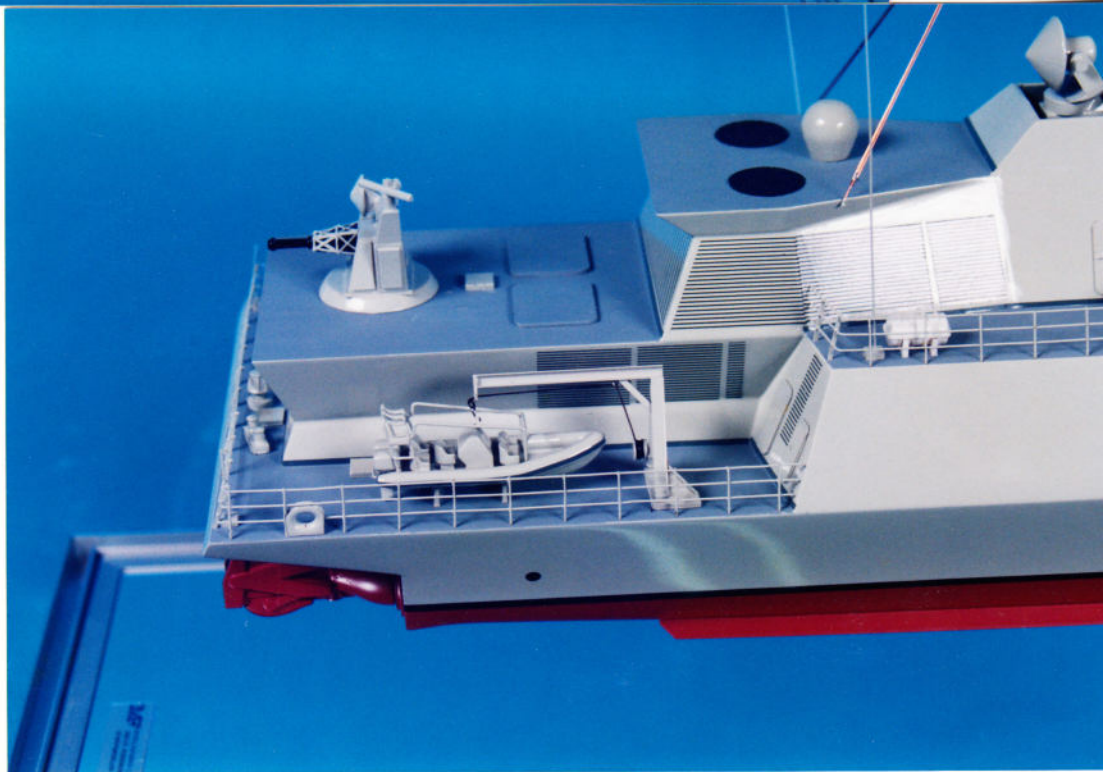
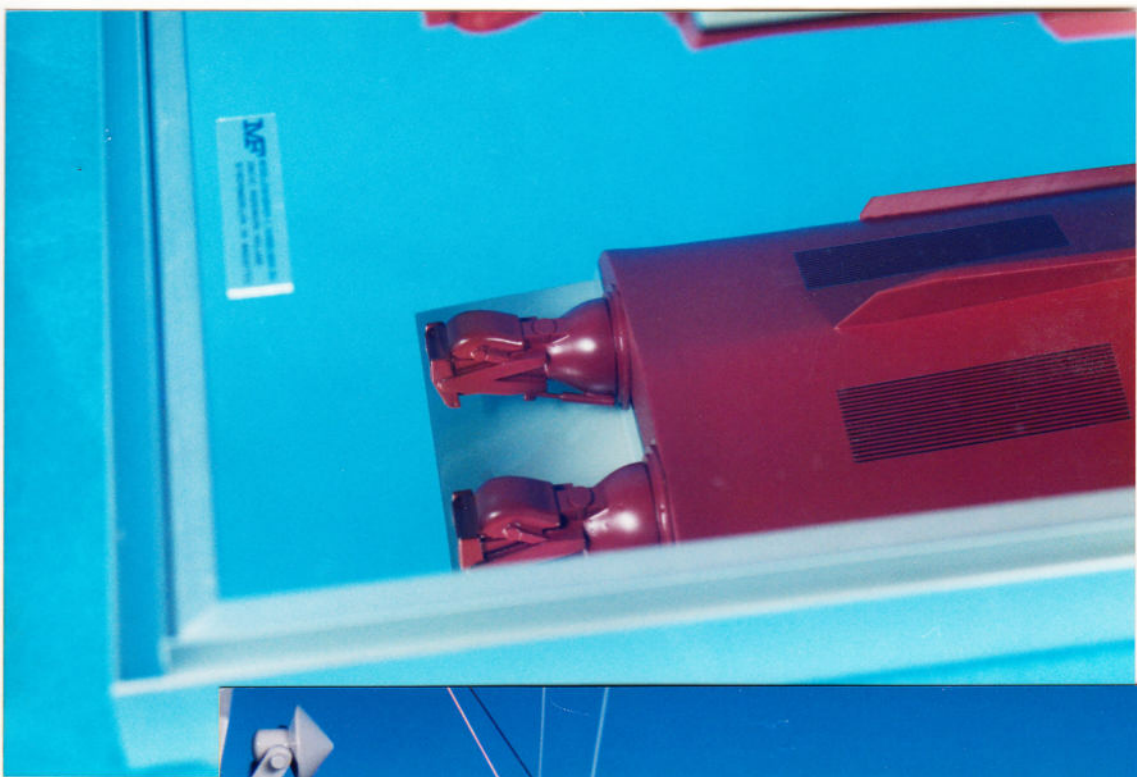

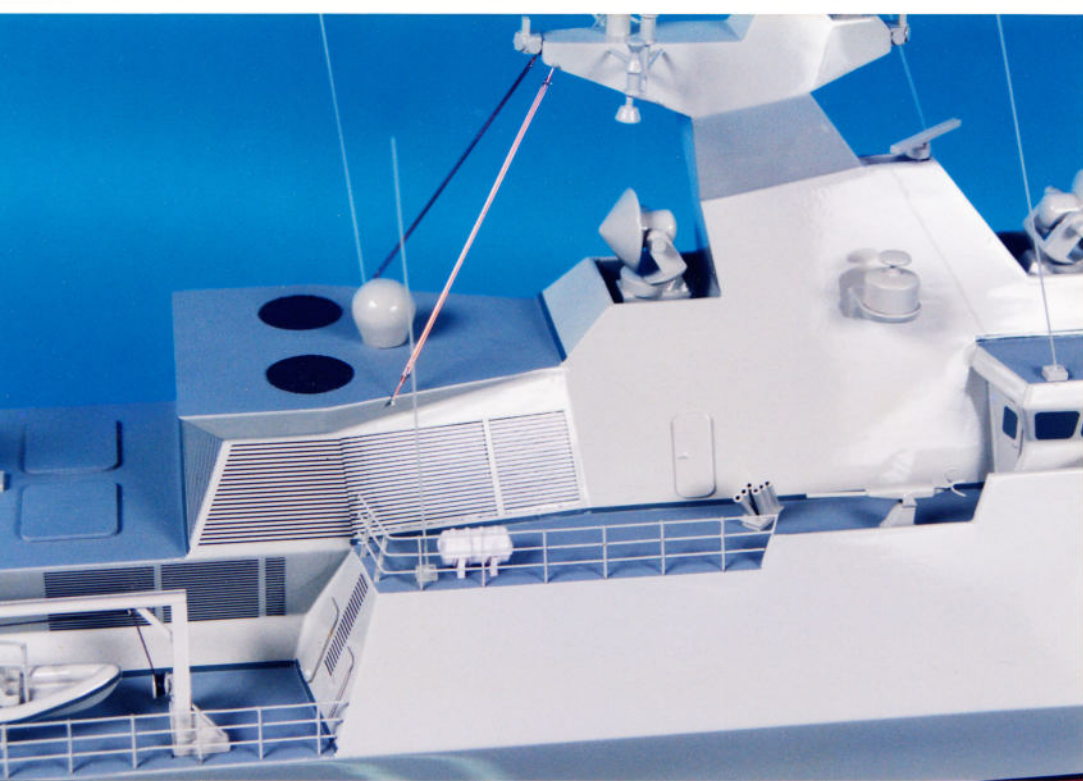

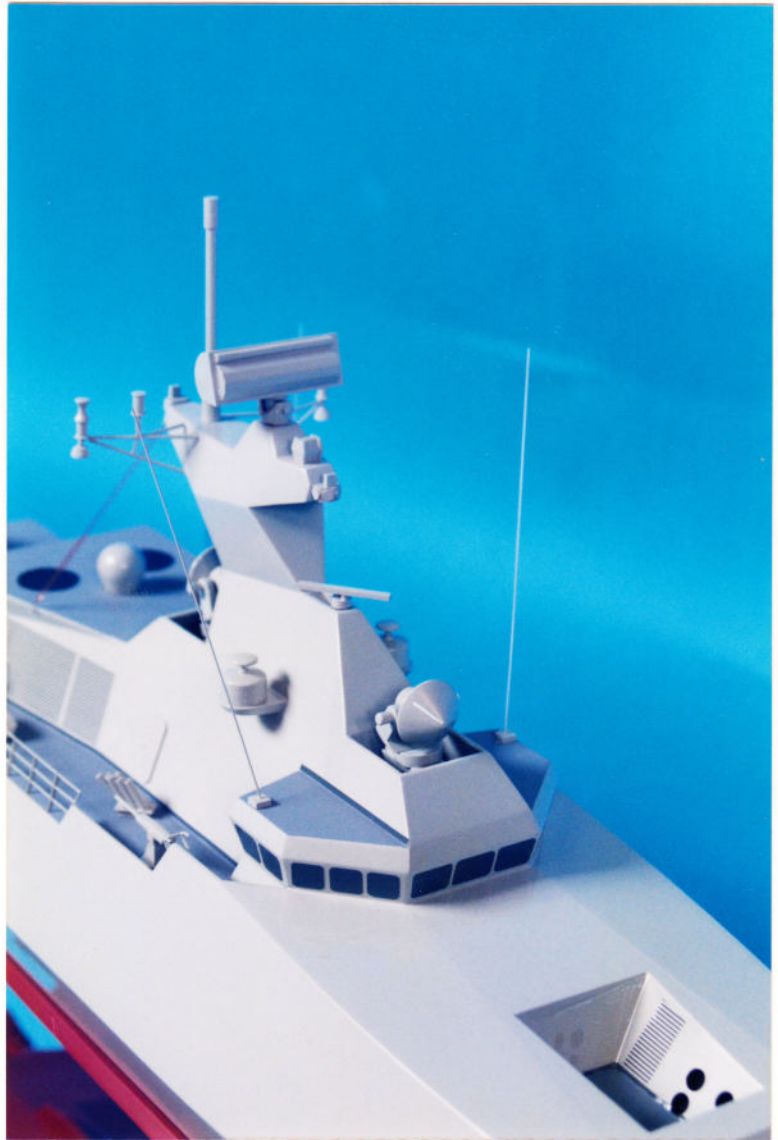





Sea Arrow 65

Sea Arrow 65

LENGTH O.A.	65.00 m
BREADTH MAX.	13.80 m
DEPTH 1-DECK	6.50 m
DRAUGHT	3.50 m
DISPLACEMENT MAX.	1190 TONNES
COMPLEMENT MAX.	24 + 18
SPEED MAX.	35 KN

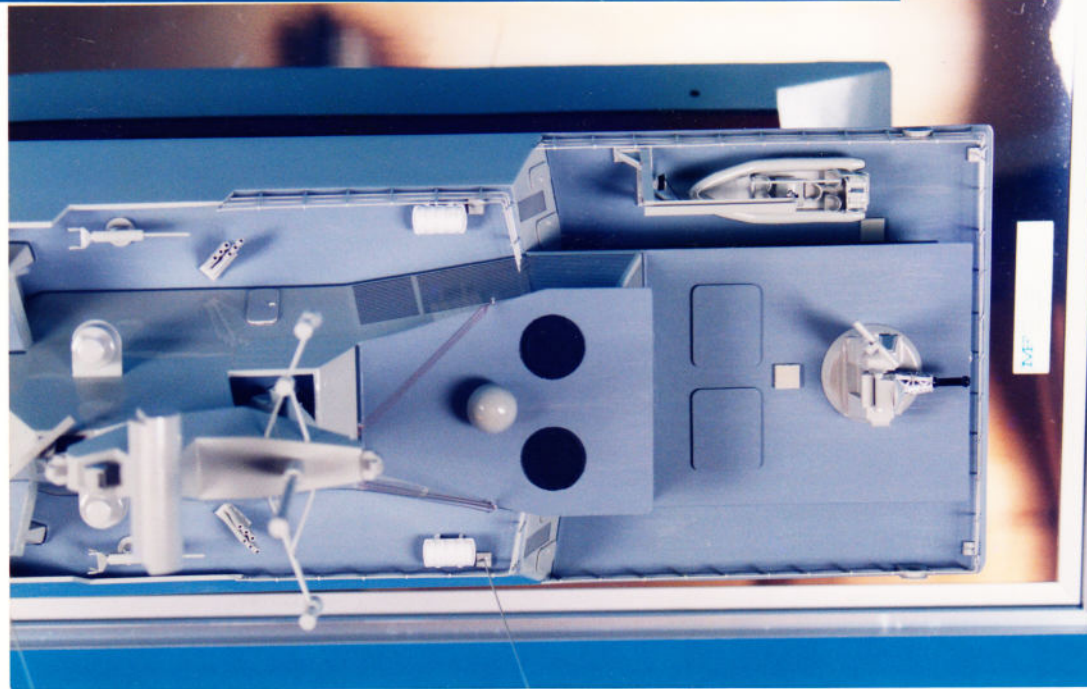
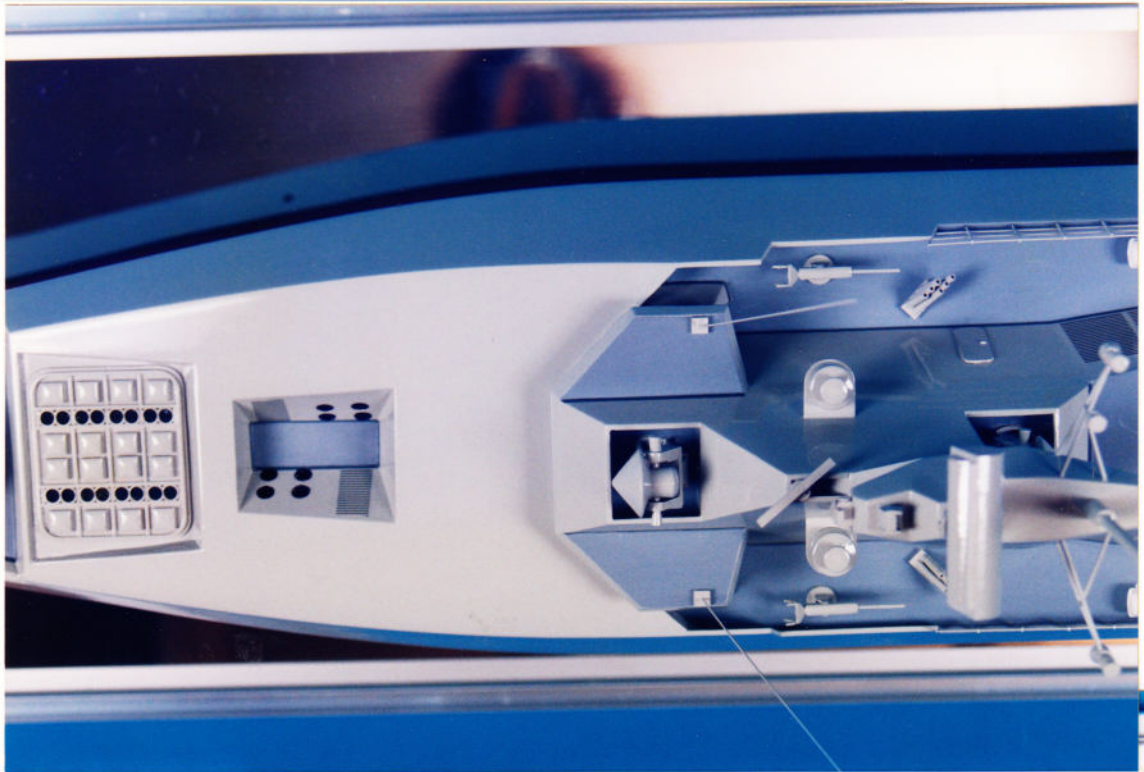



USS Zumwalt (DDG 1000)
LENGTH: 1,800 FT.
DISPLACEMENT: 12,000 TONS
SPEED: 30 KNOTS
COMPLEMENT: 270 CREW
ARMAMENT: 100 MISSILES



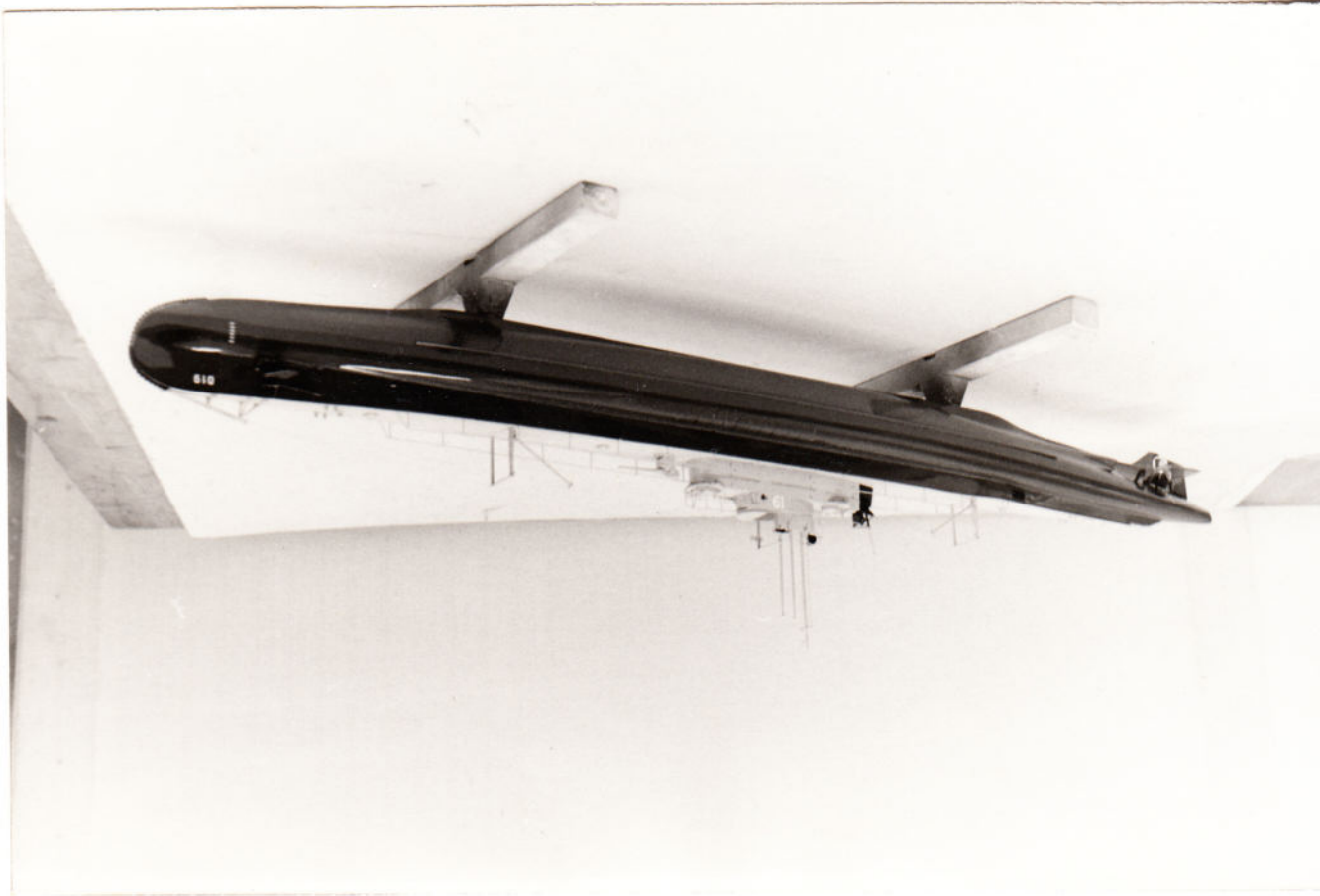
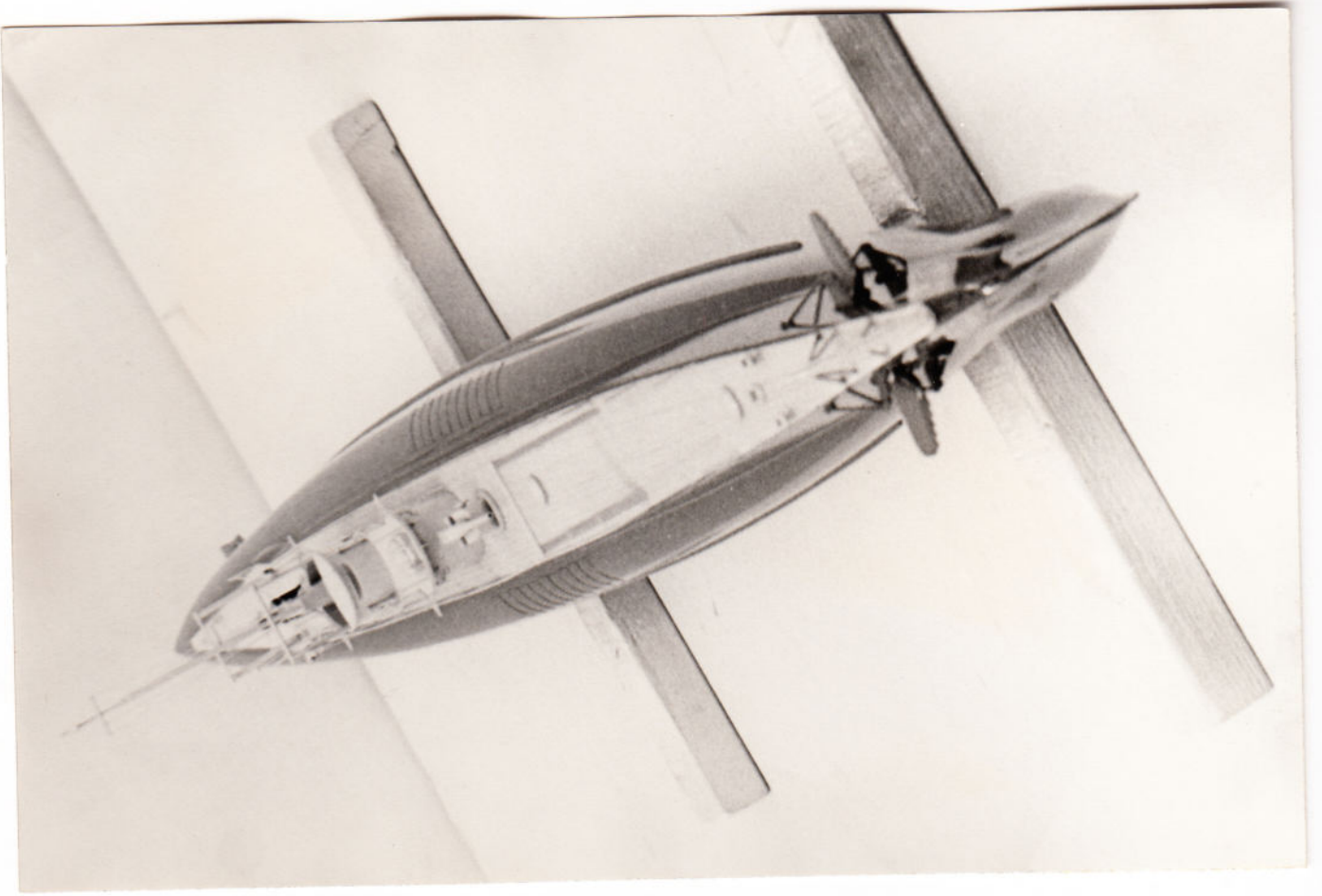

019
2x
1965
NEWSBY
1:100

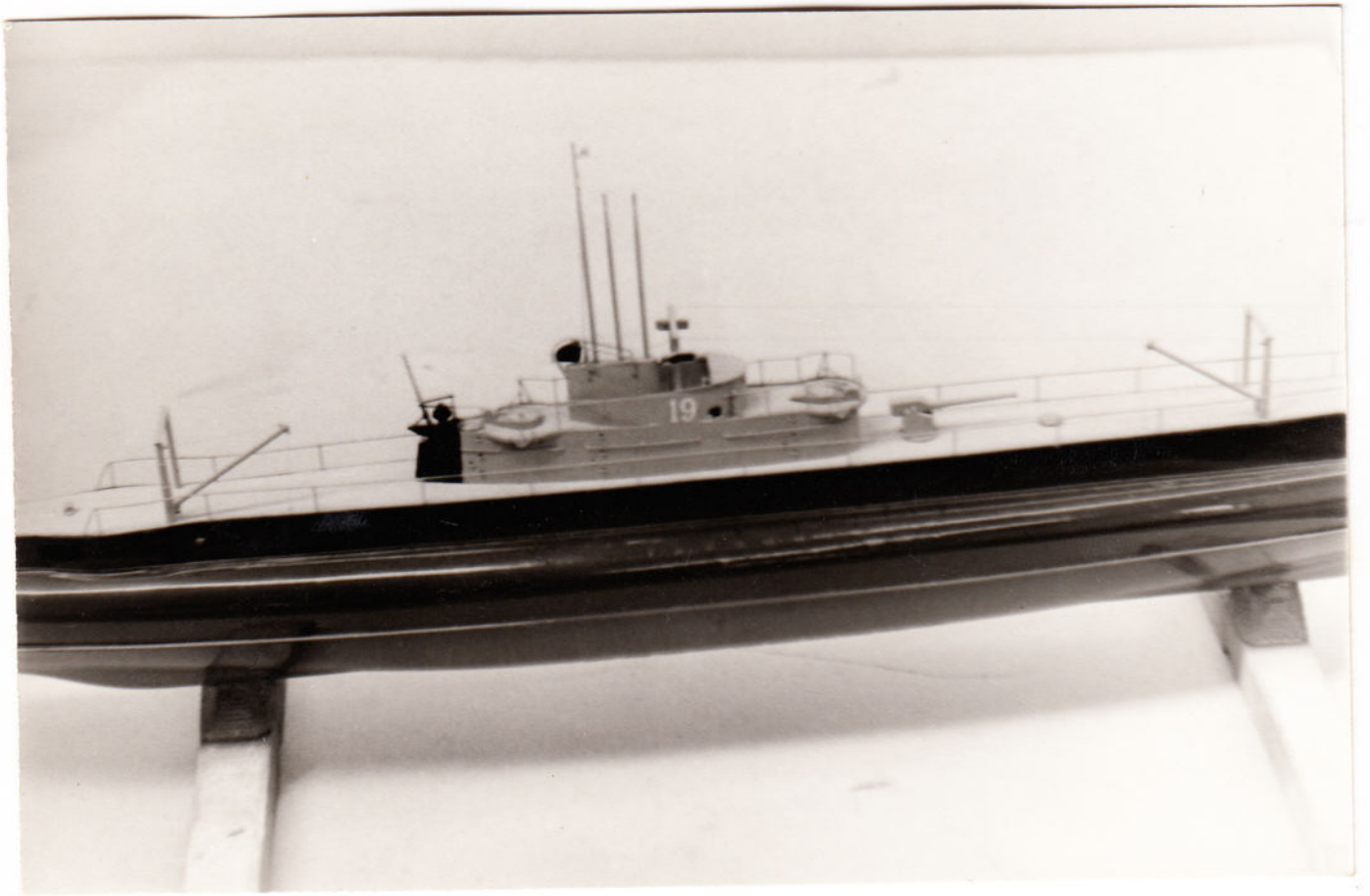
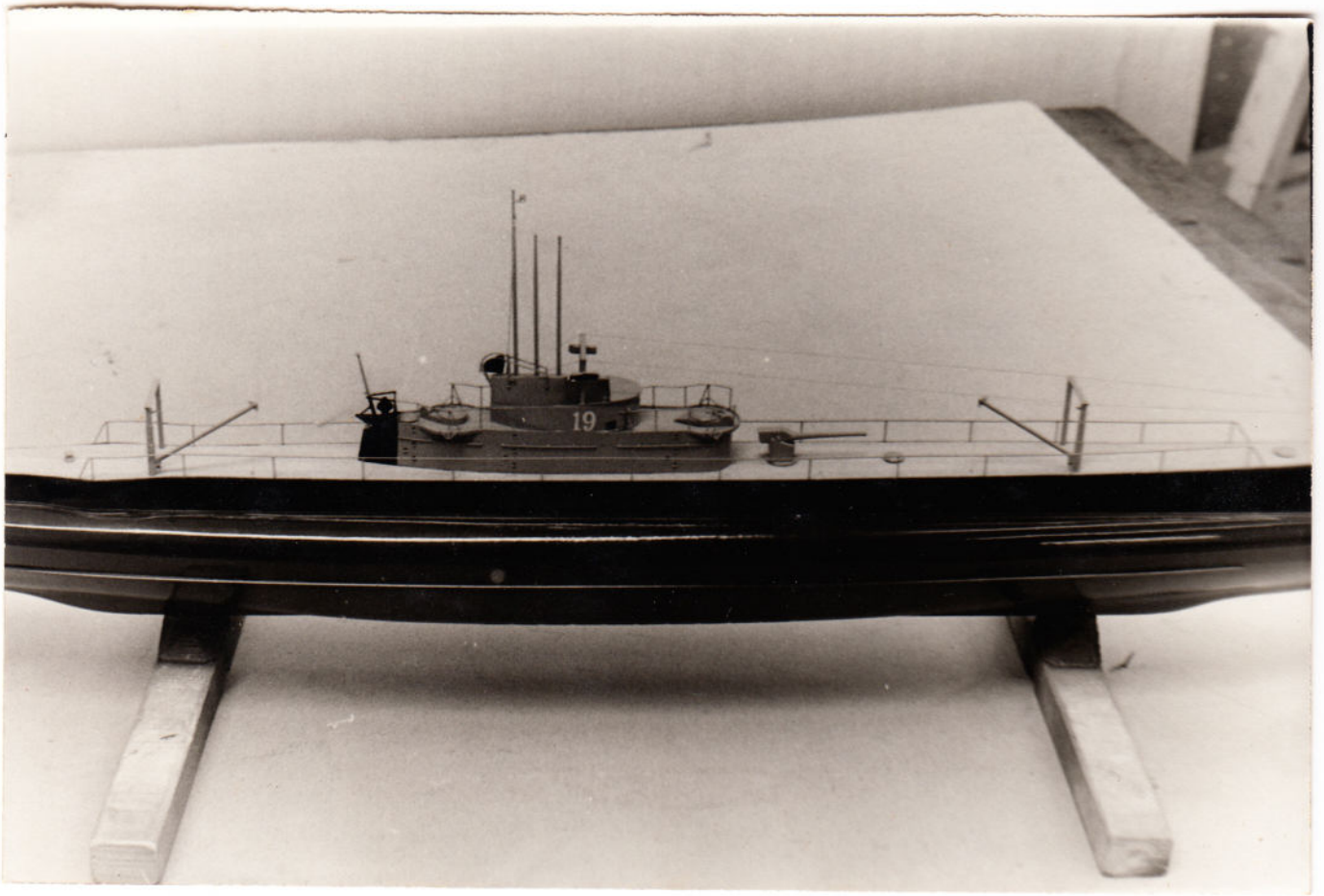

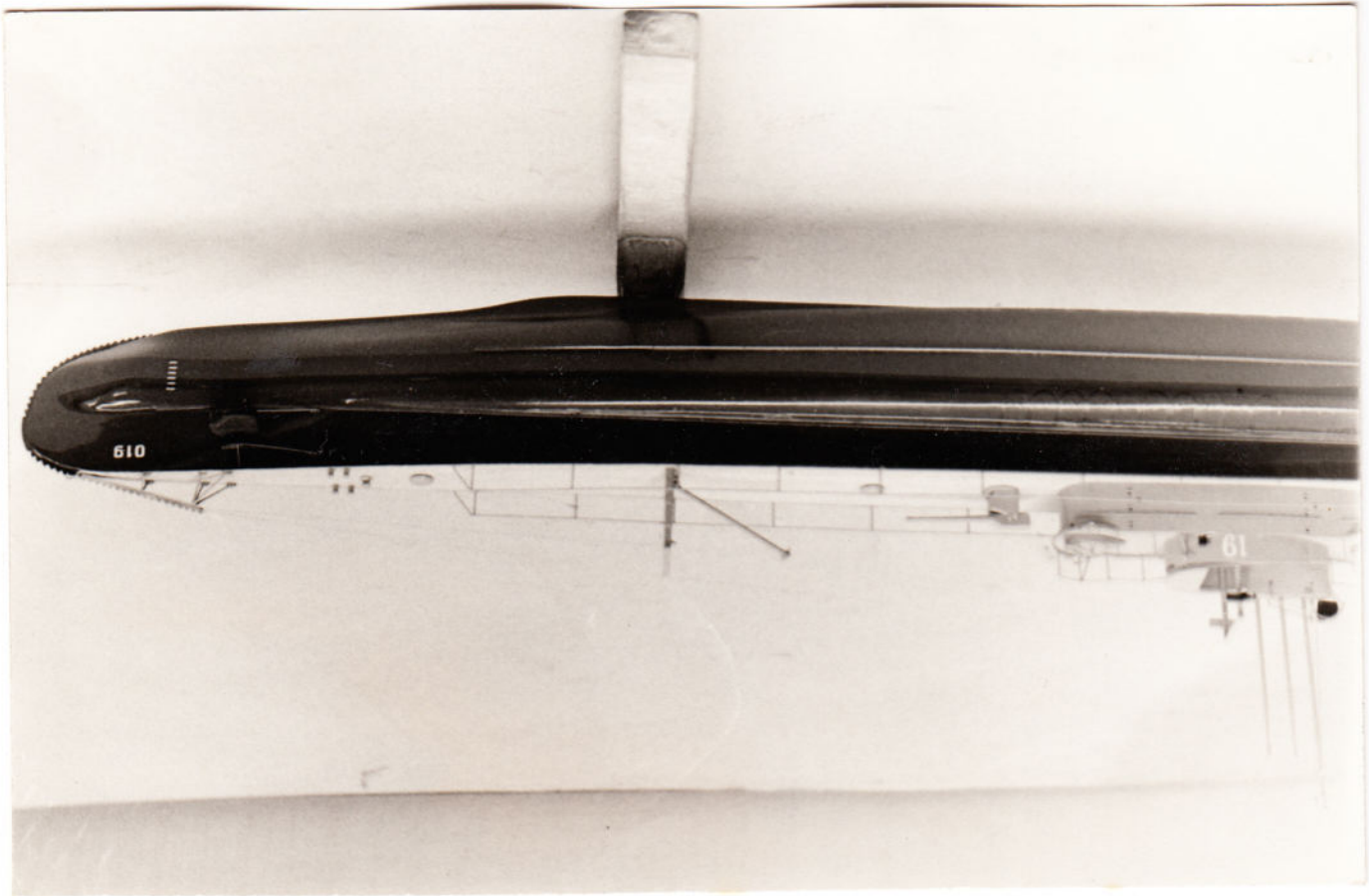
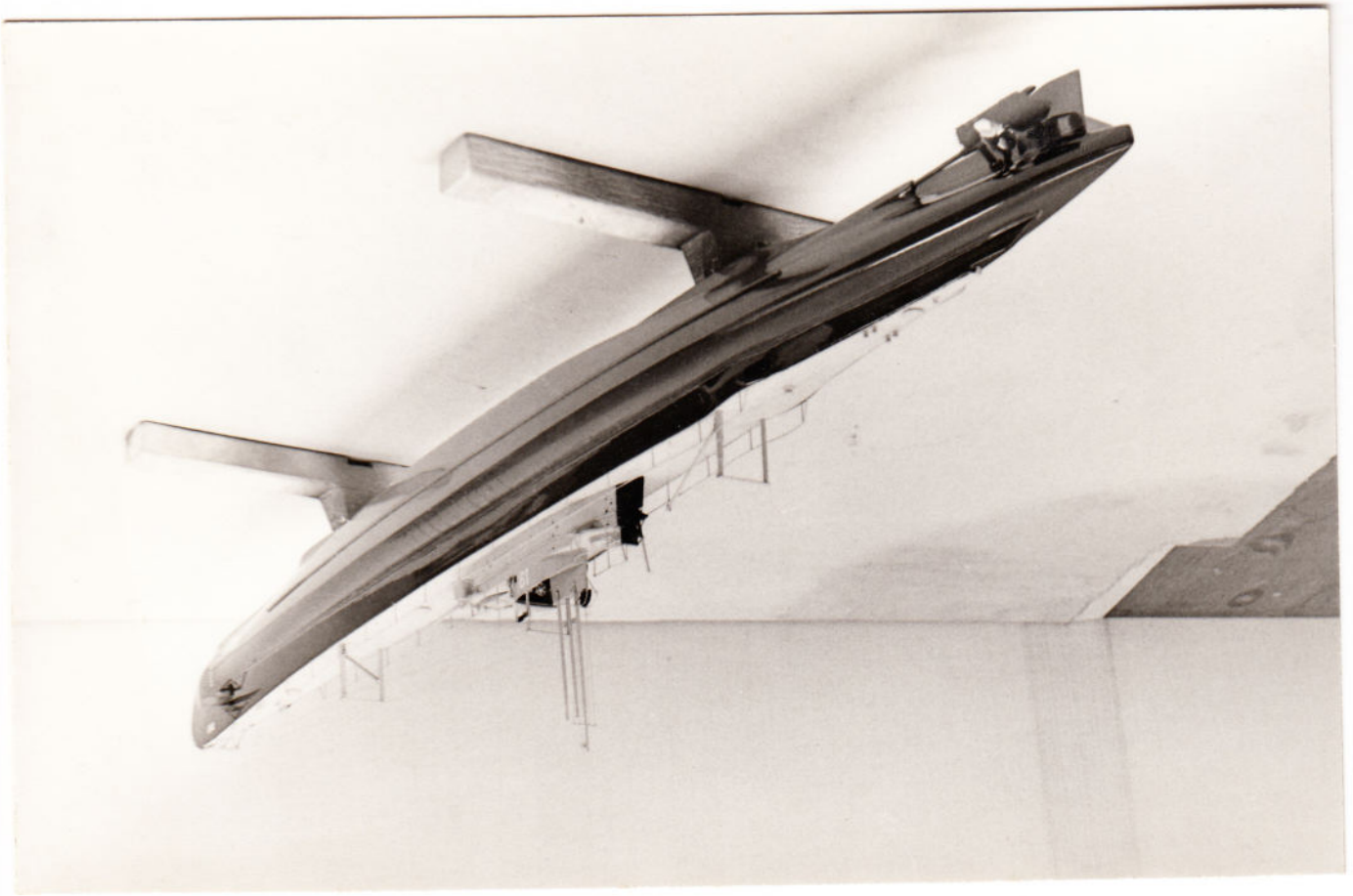

Marine

1966

Potvis +

doornsteden

1840

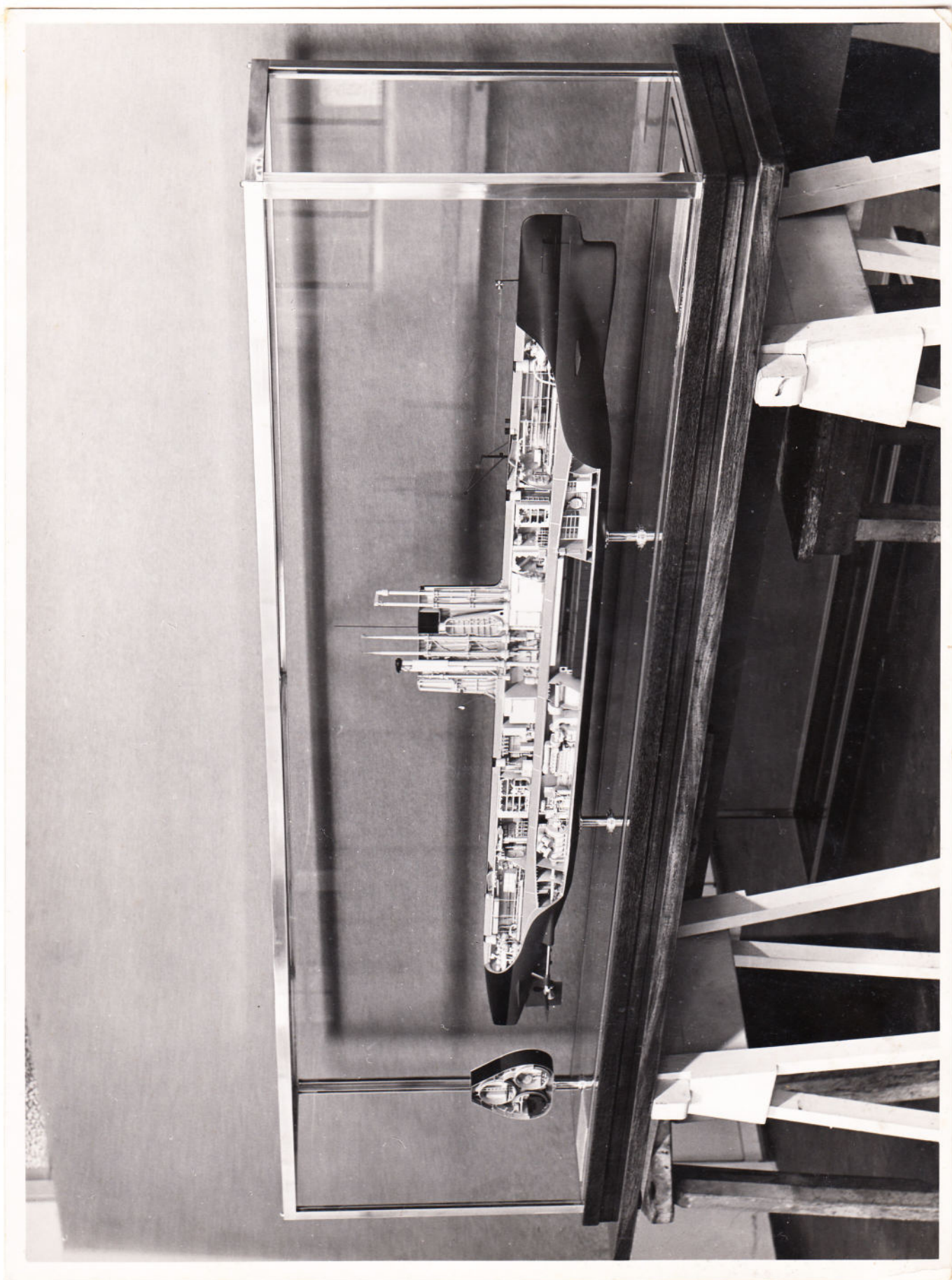

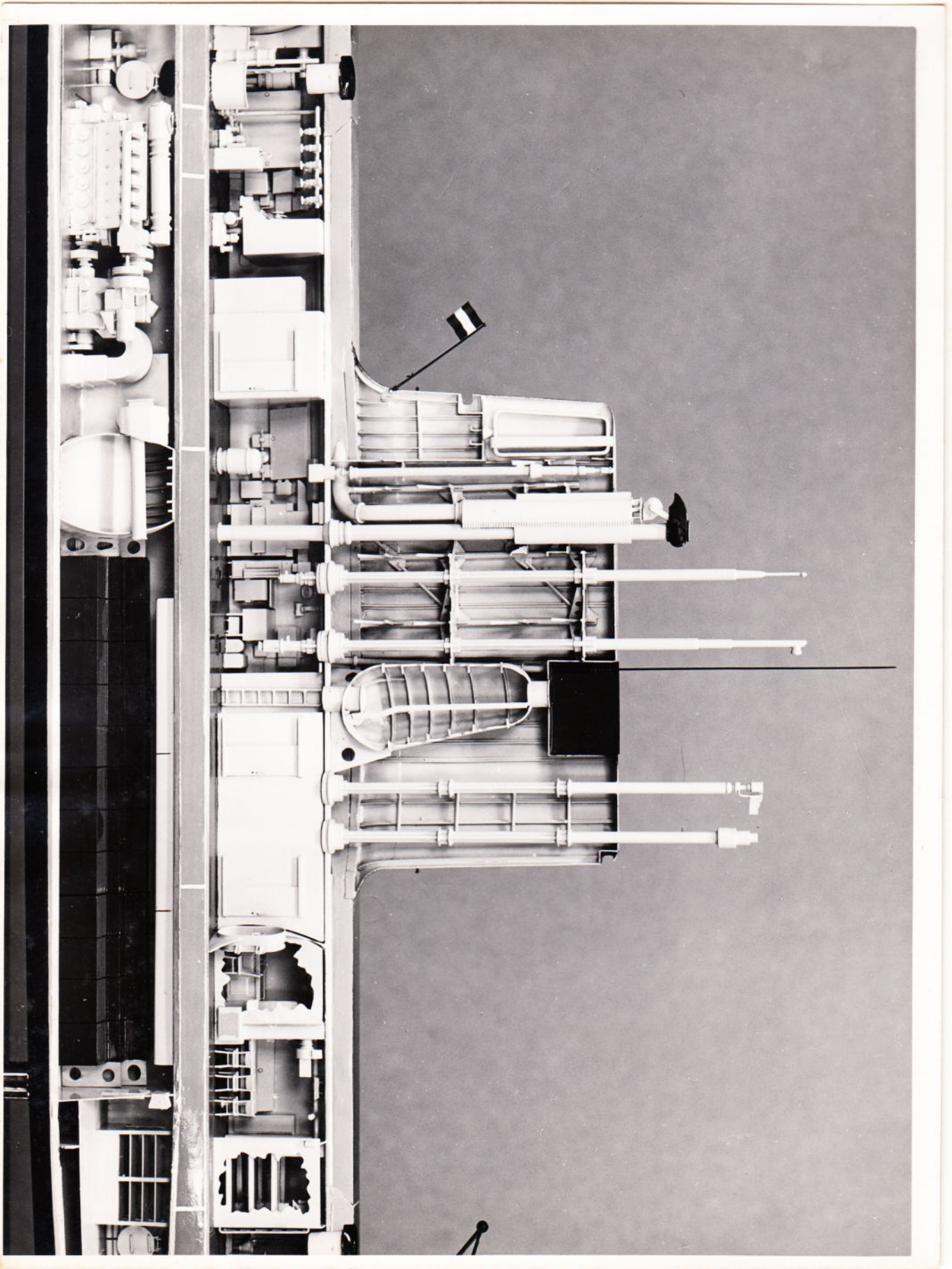

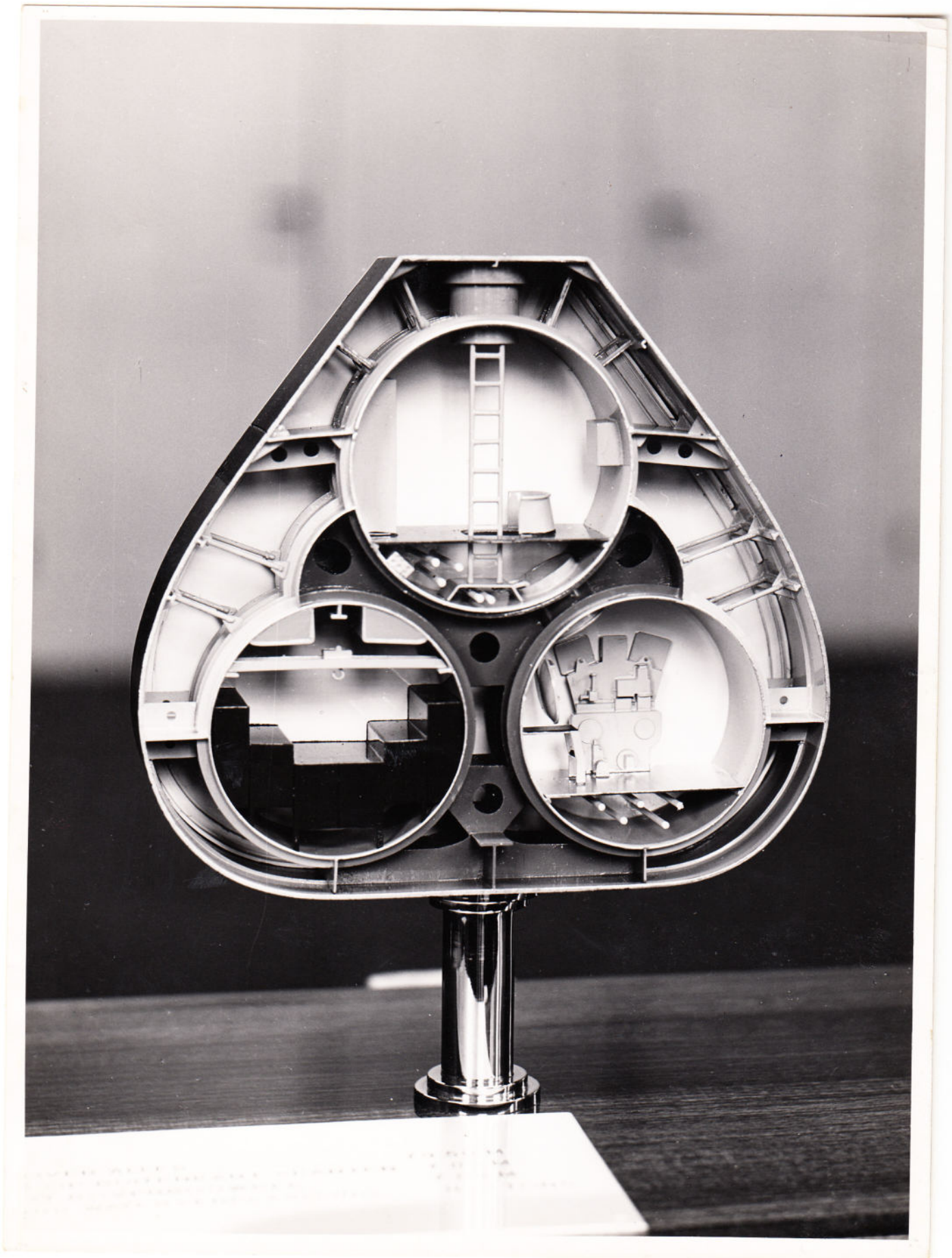

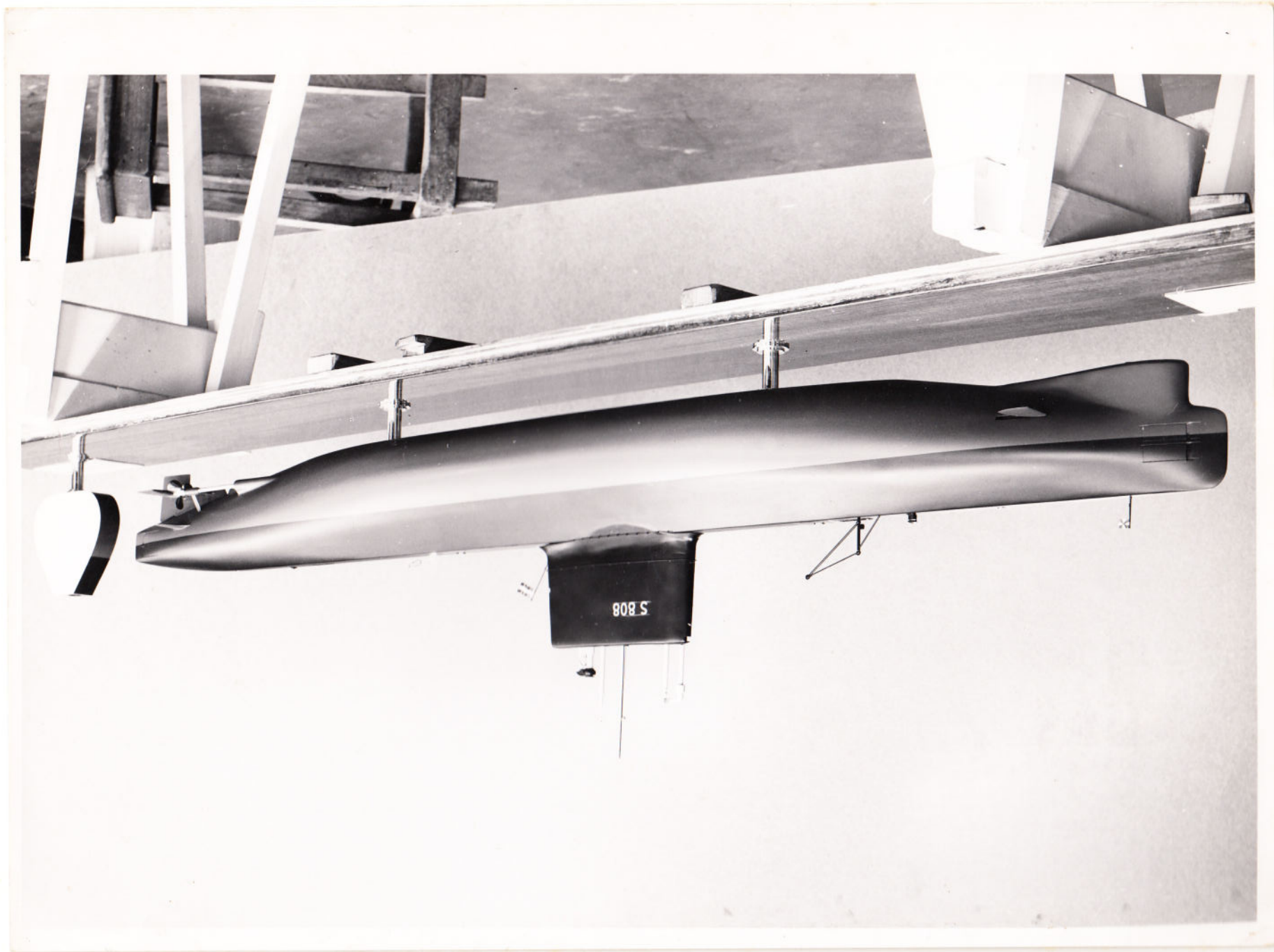

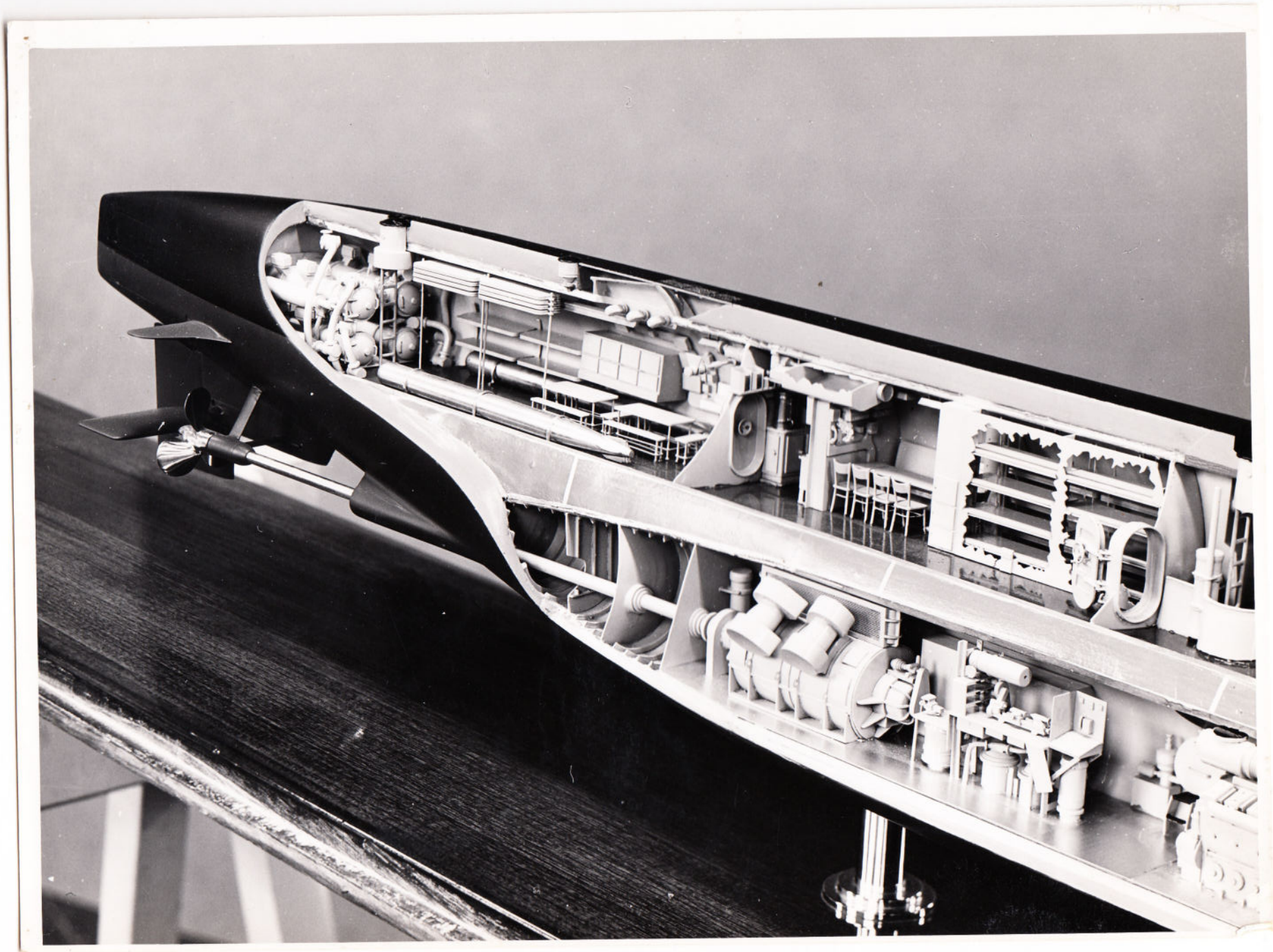

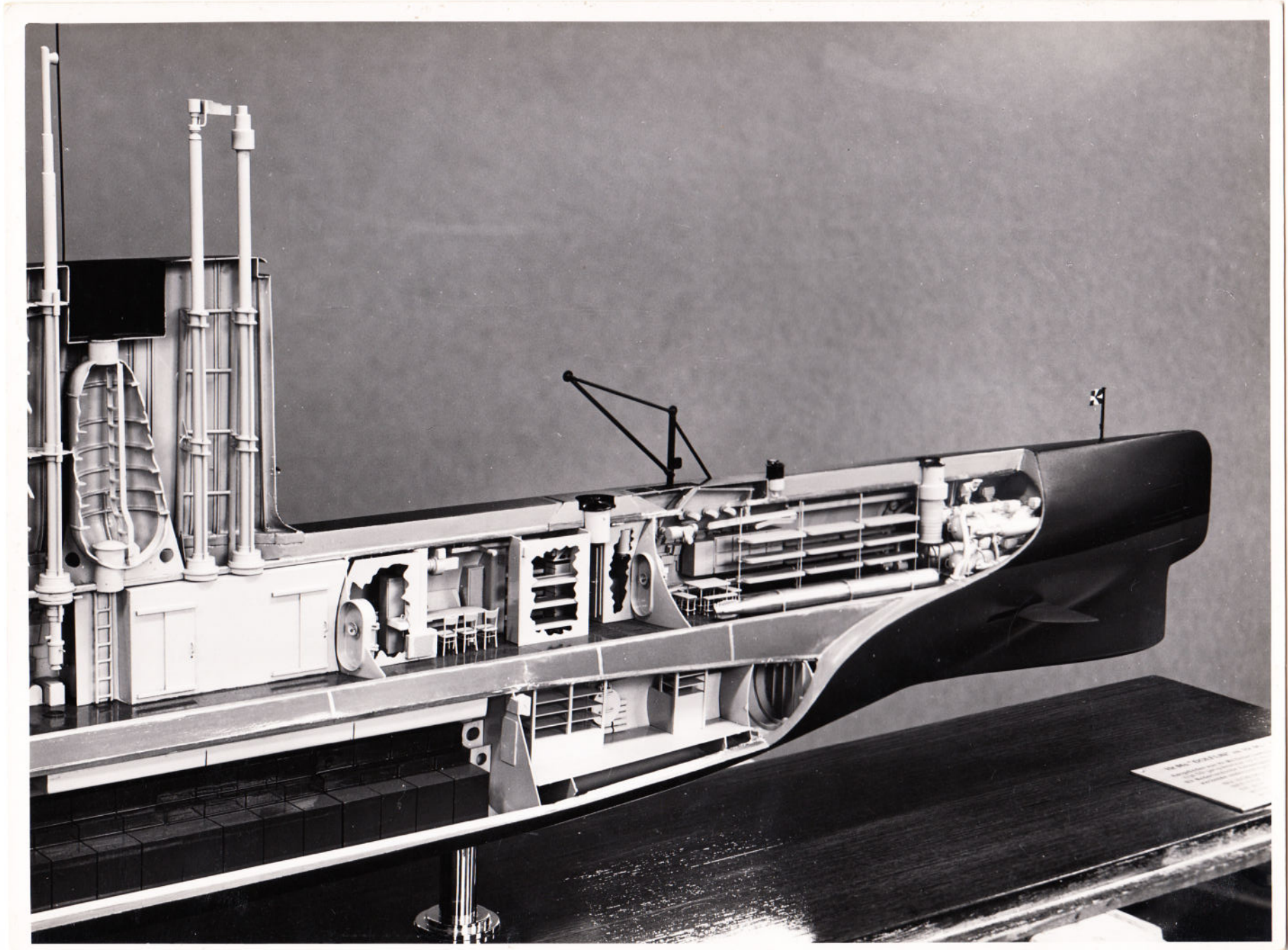

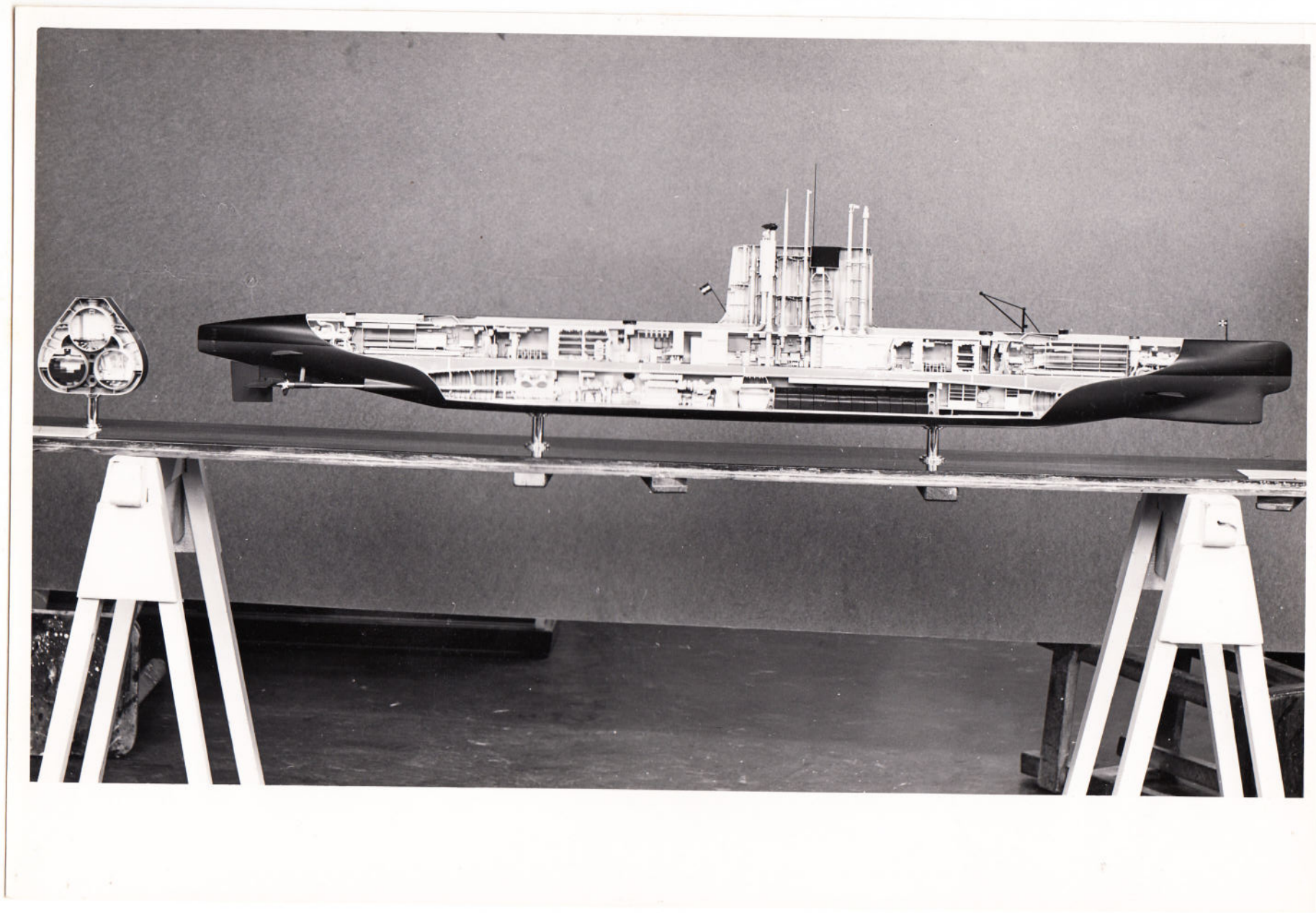

POTUIS
1966

INSTRUCTIE MODEL ~~REDA~~ POTUIS 1966

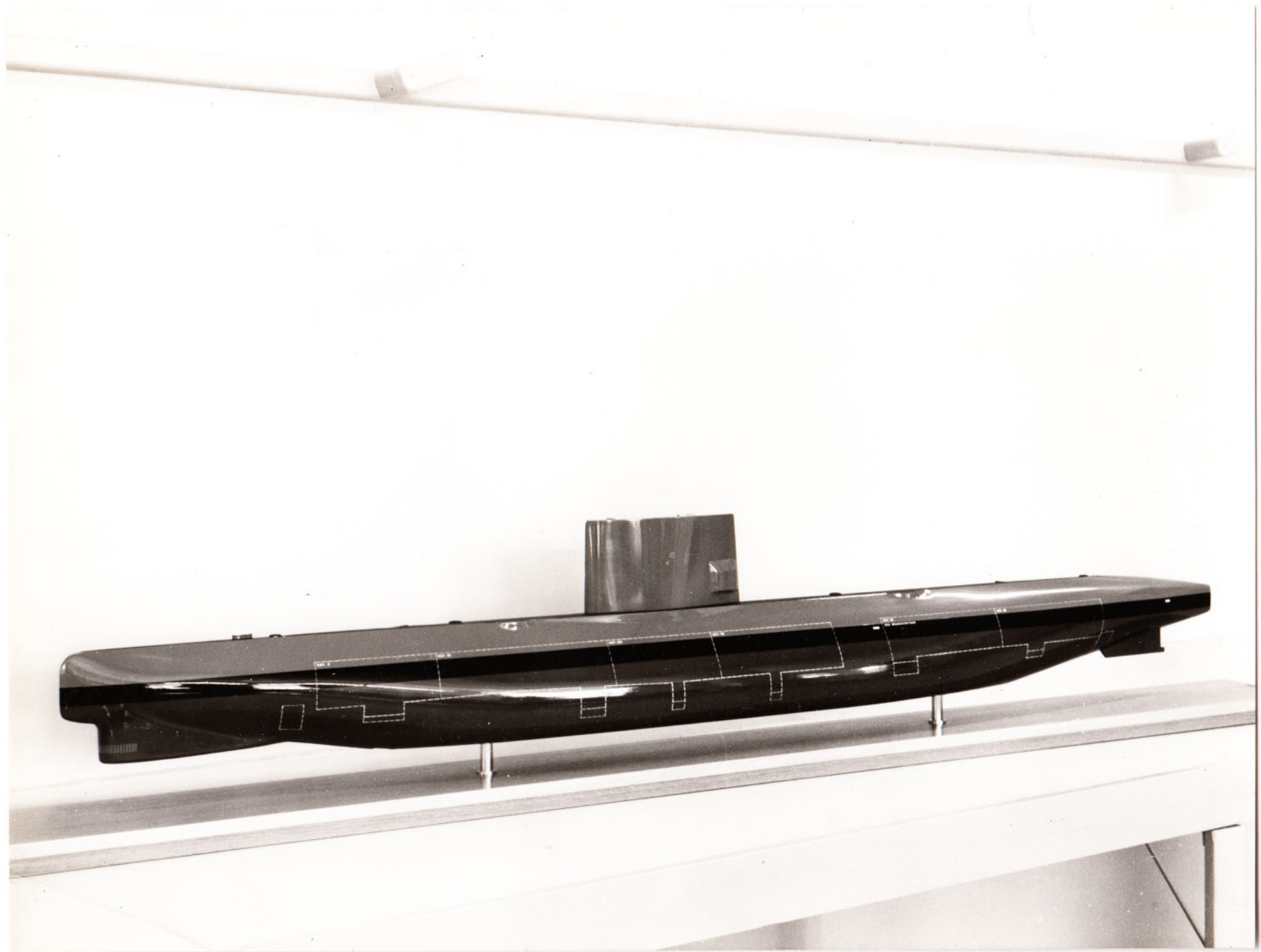



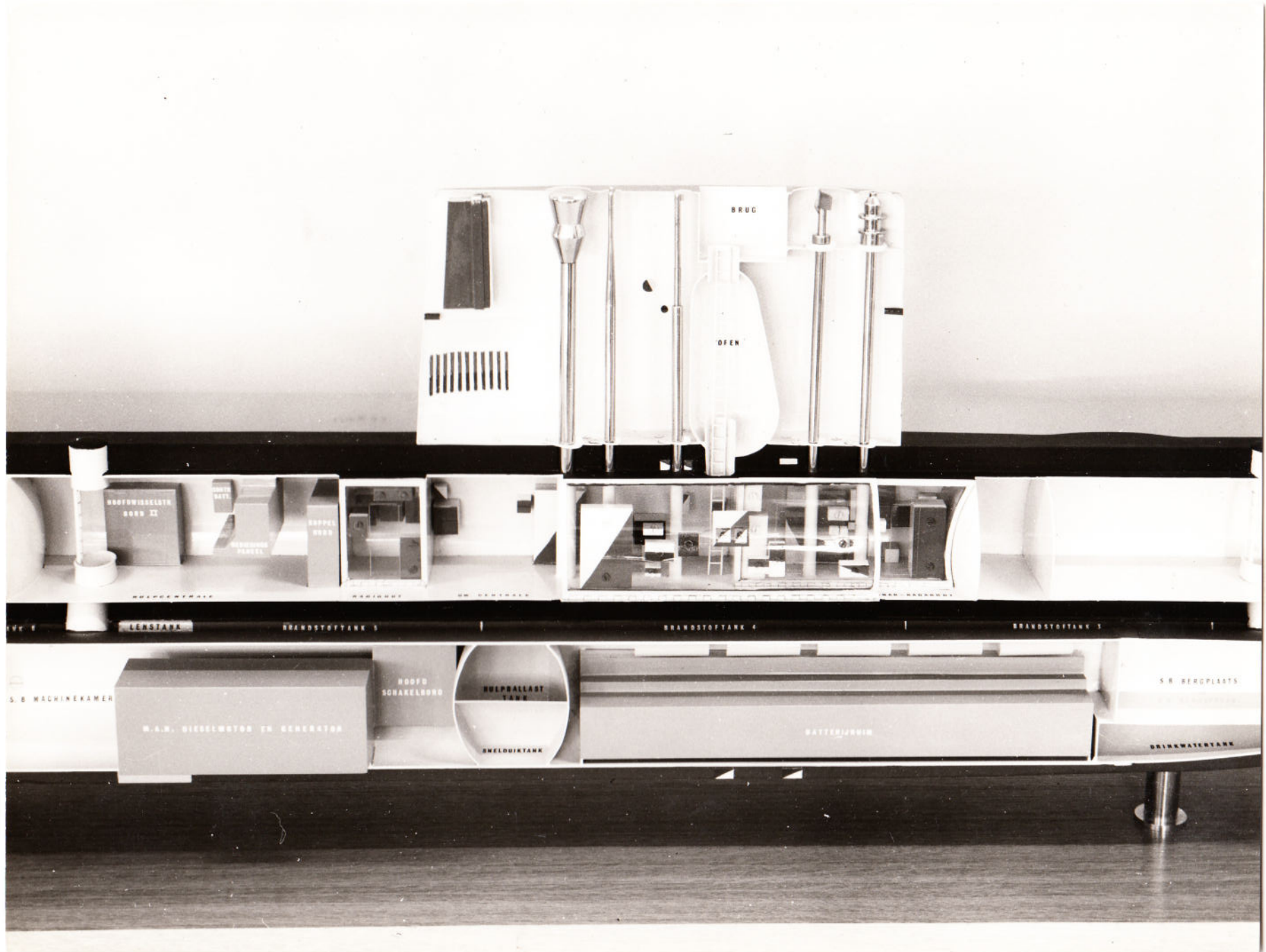

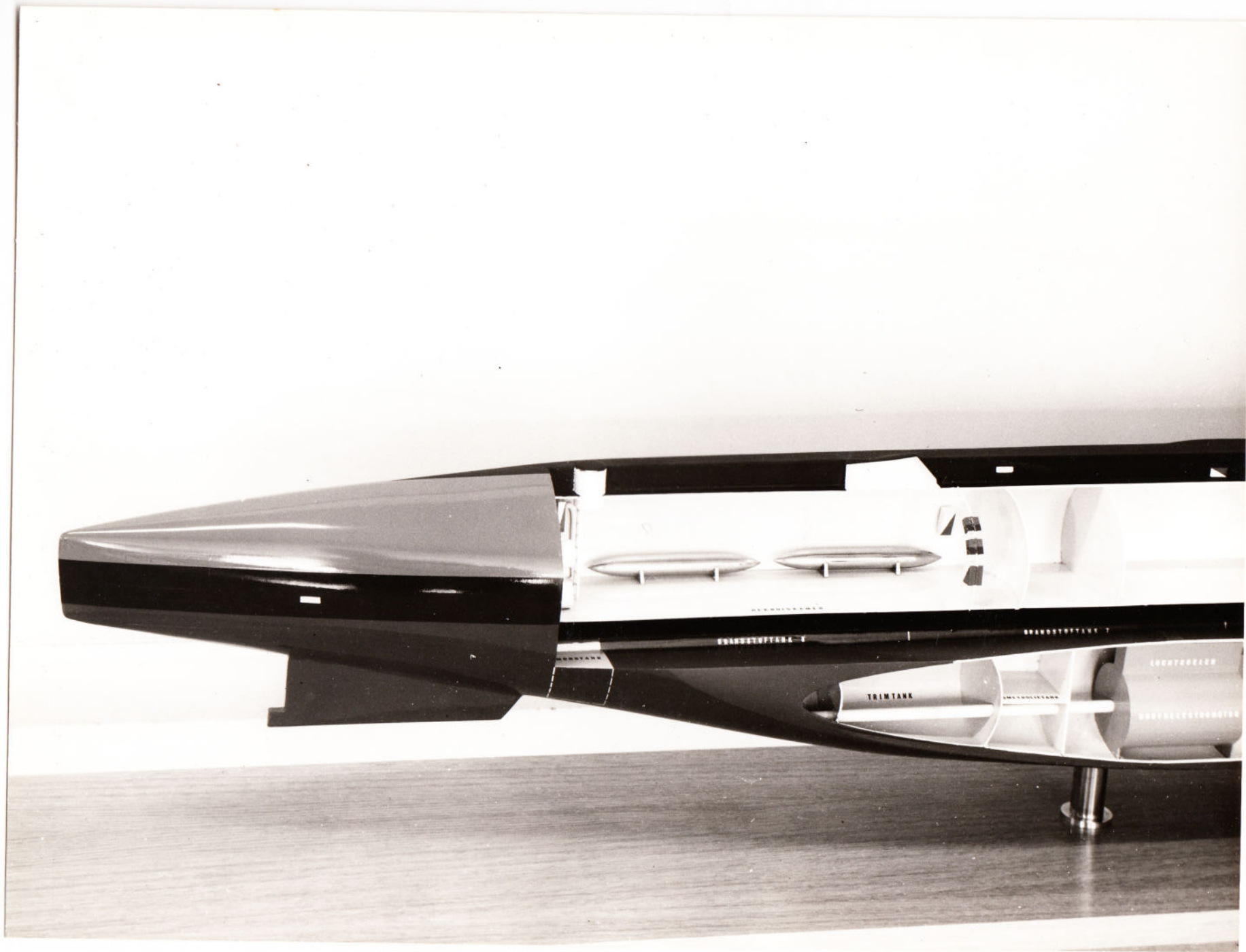

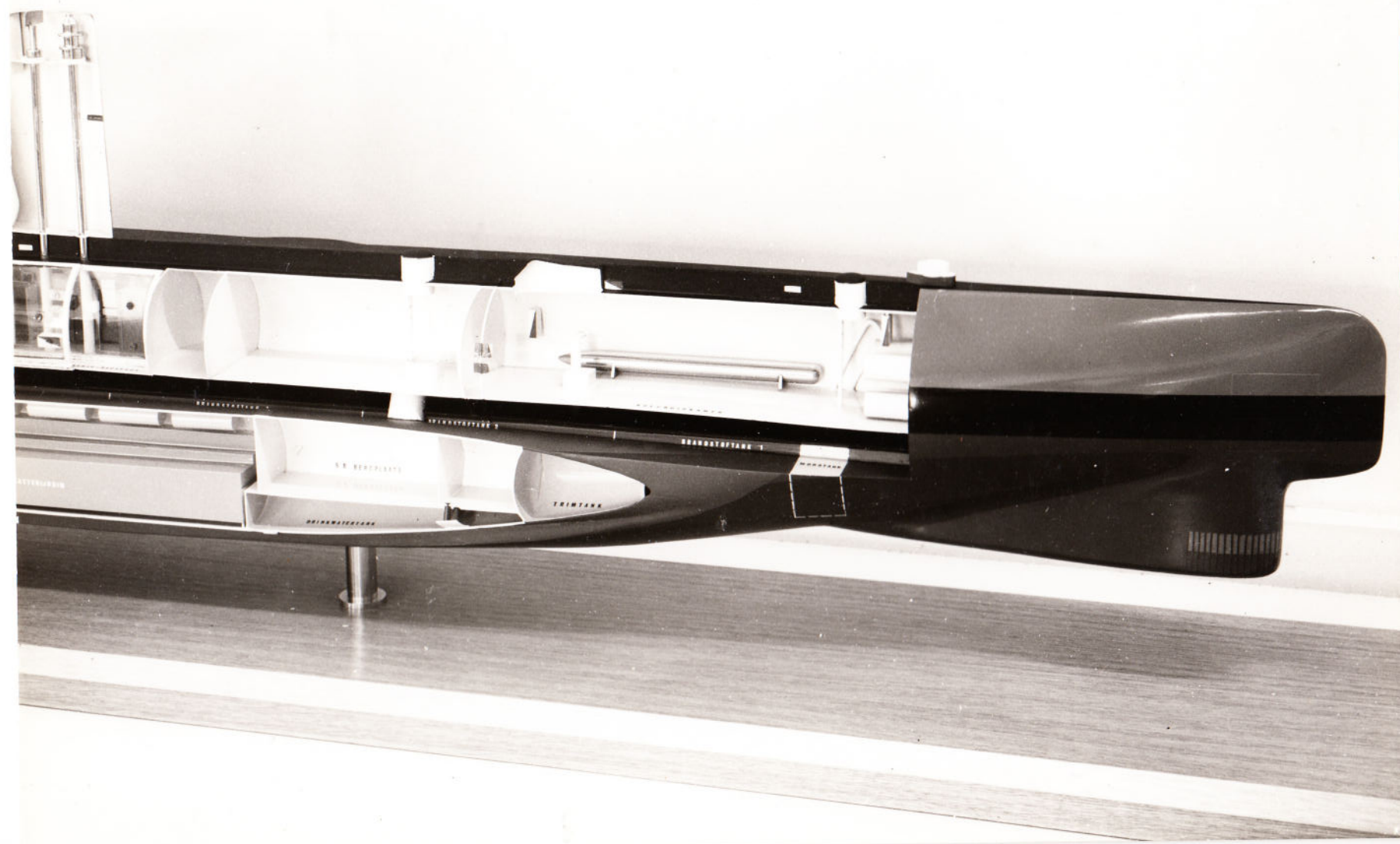

ZWAARDUIS

1972

1:50

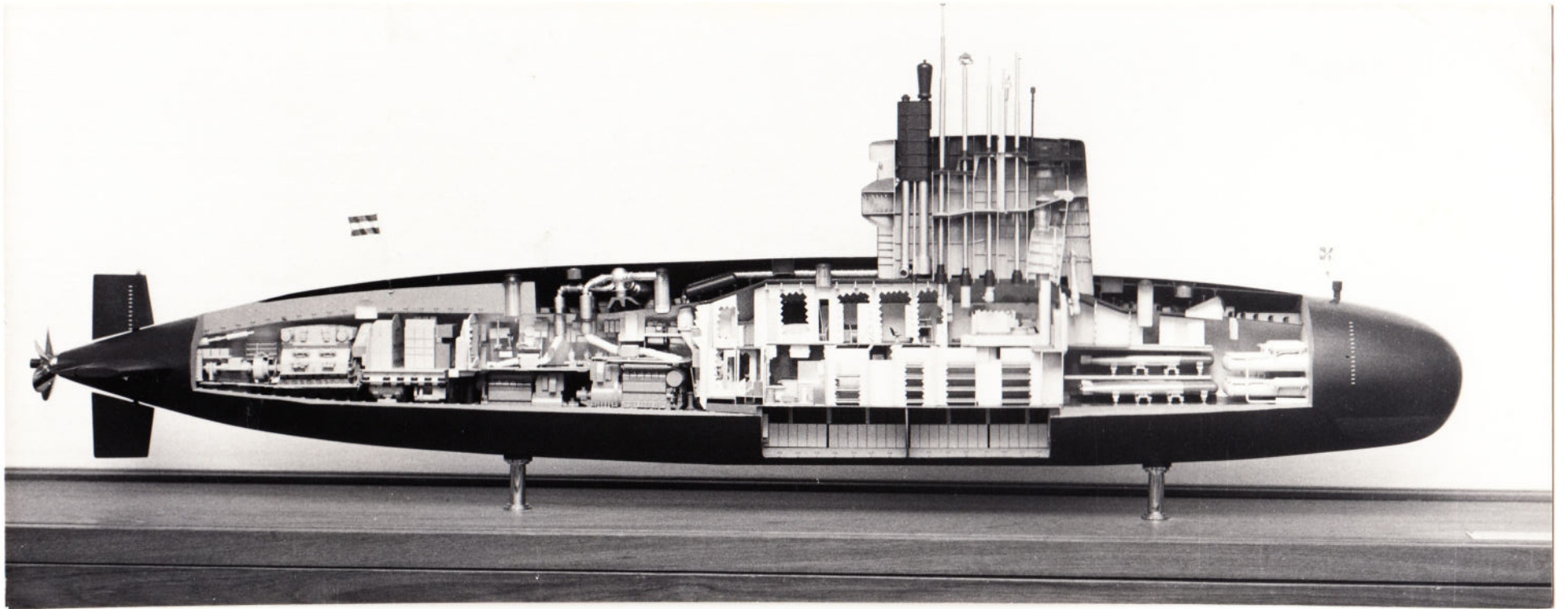

EDWARDS

1972



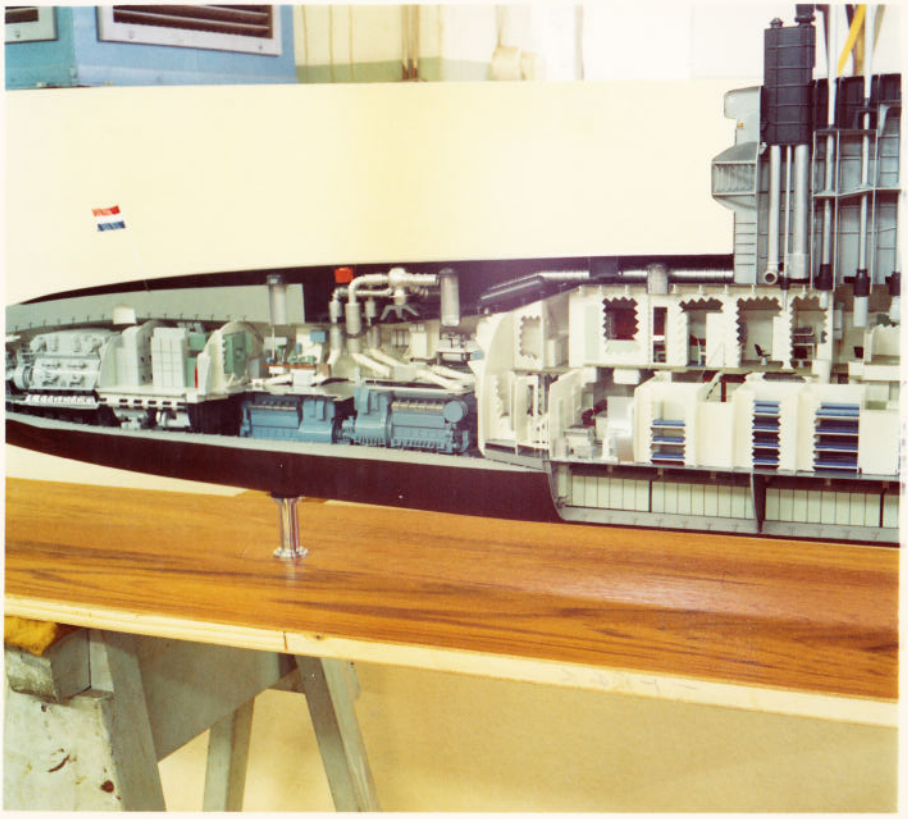
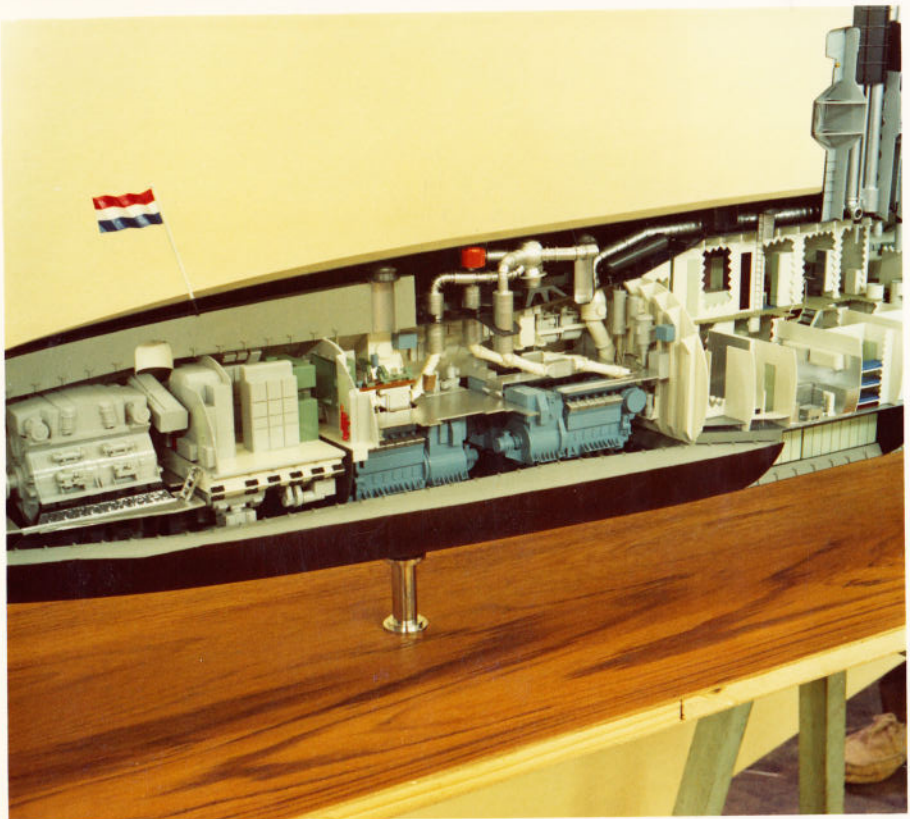
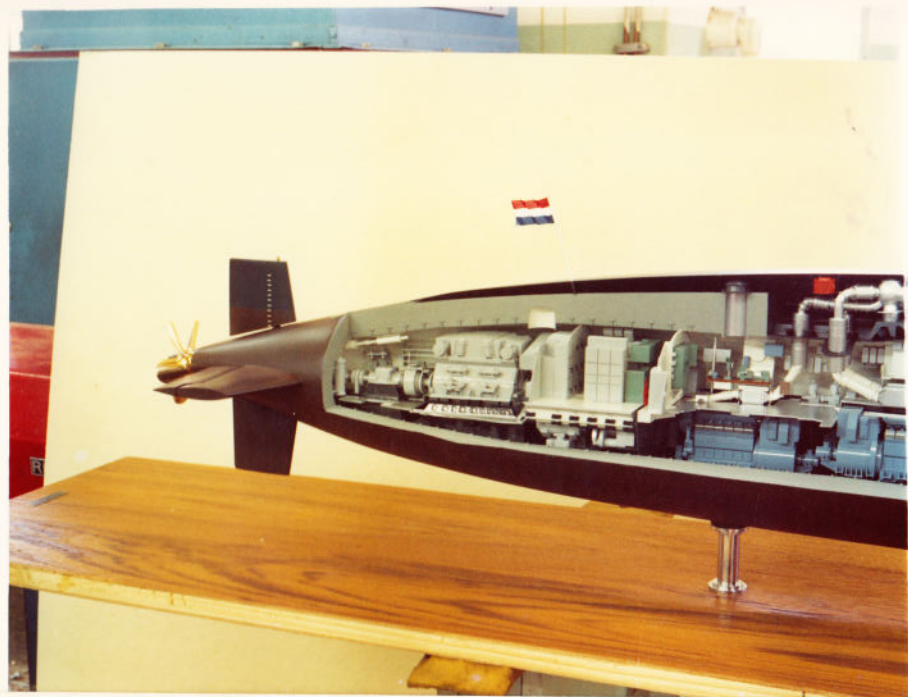
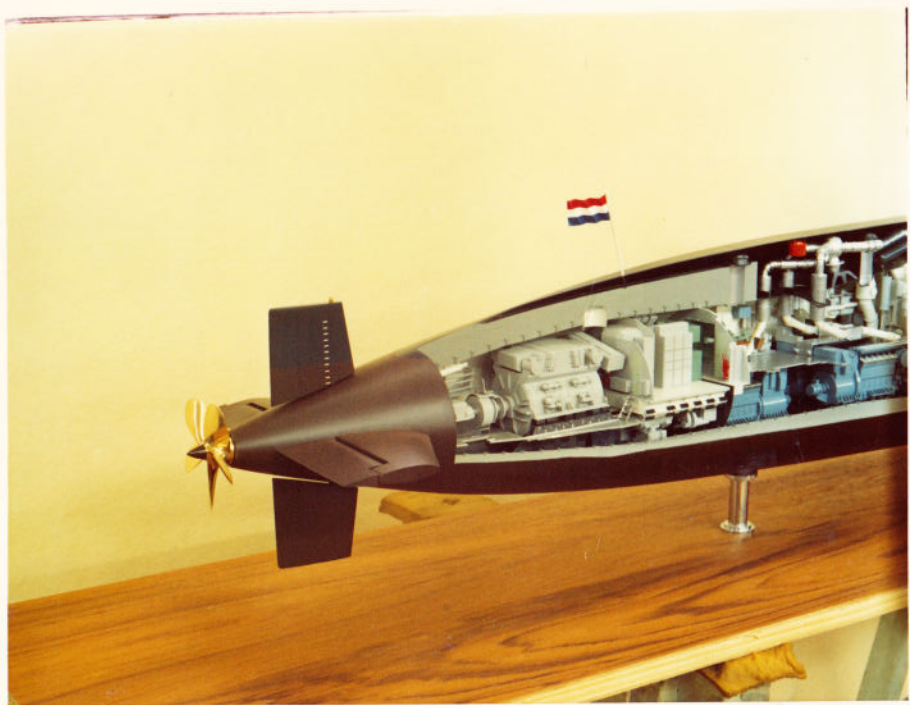

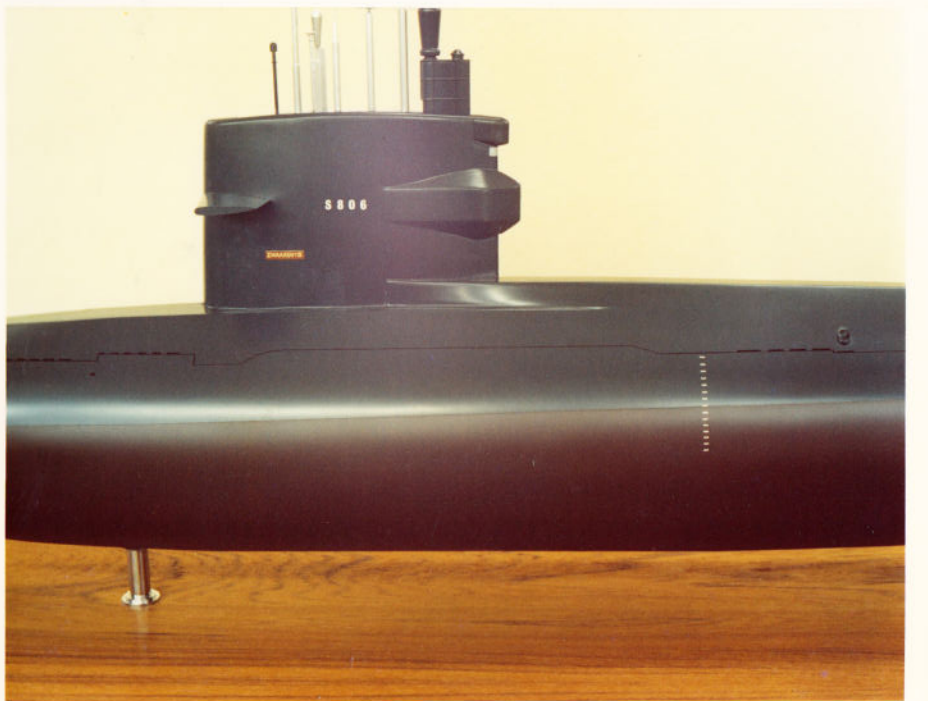
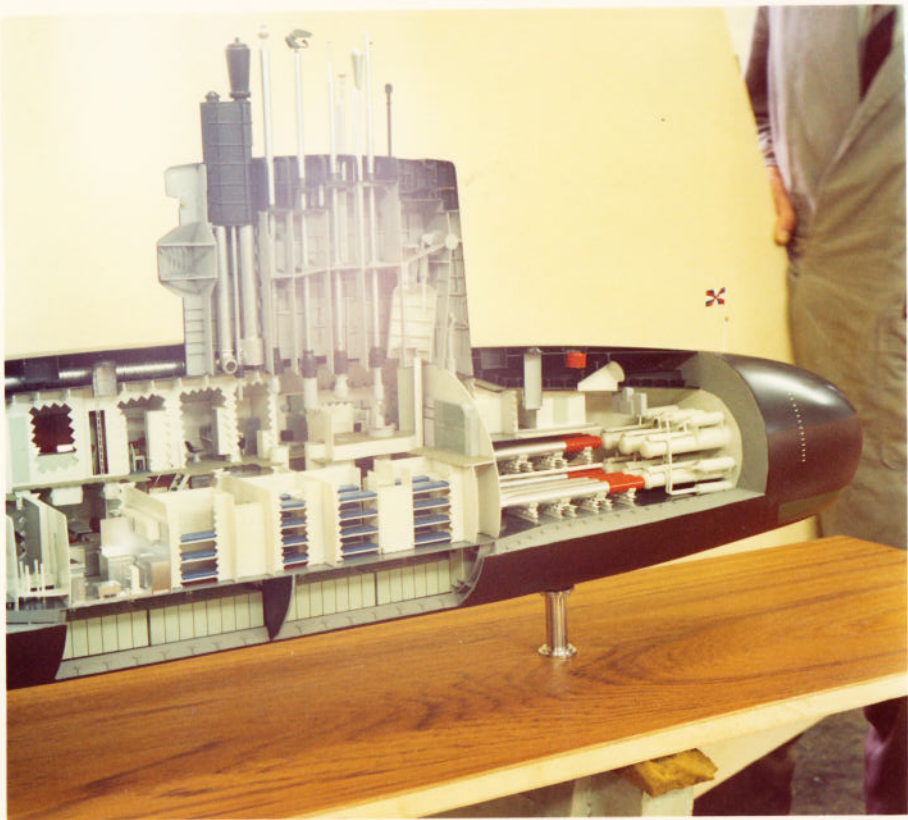
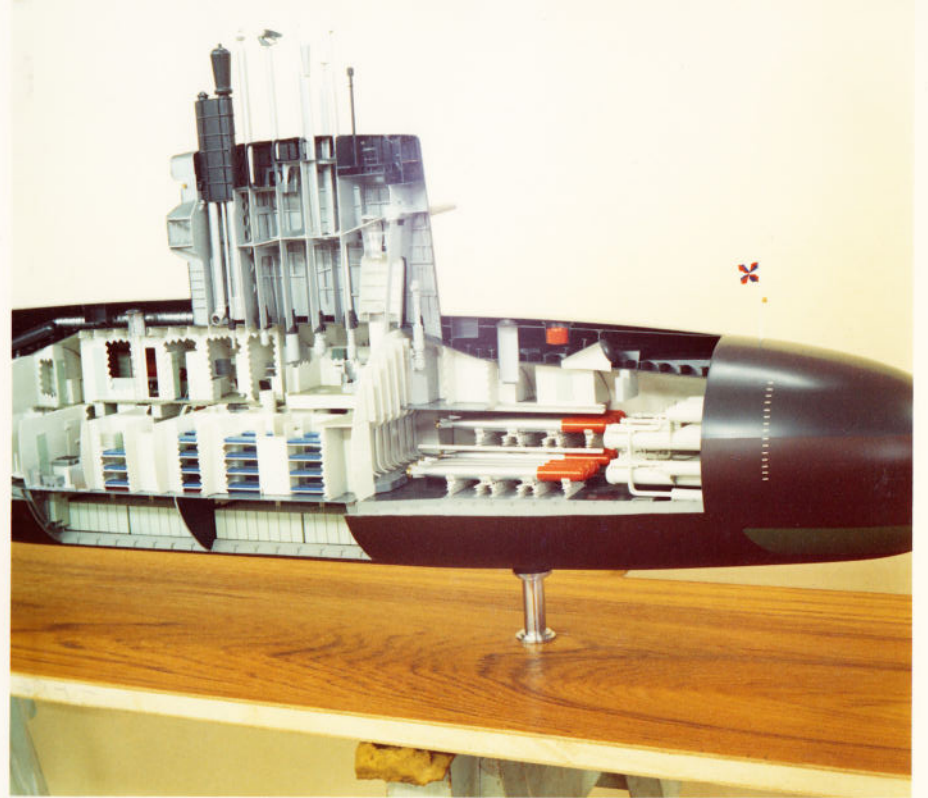
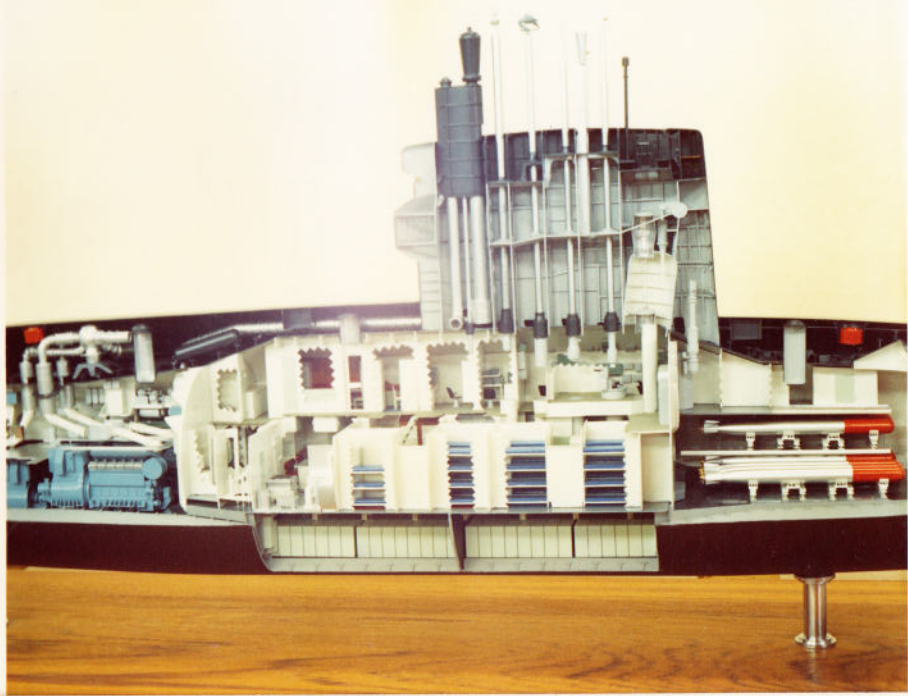



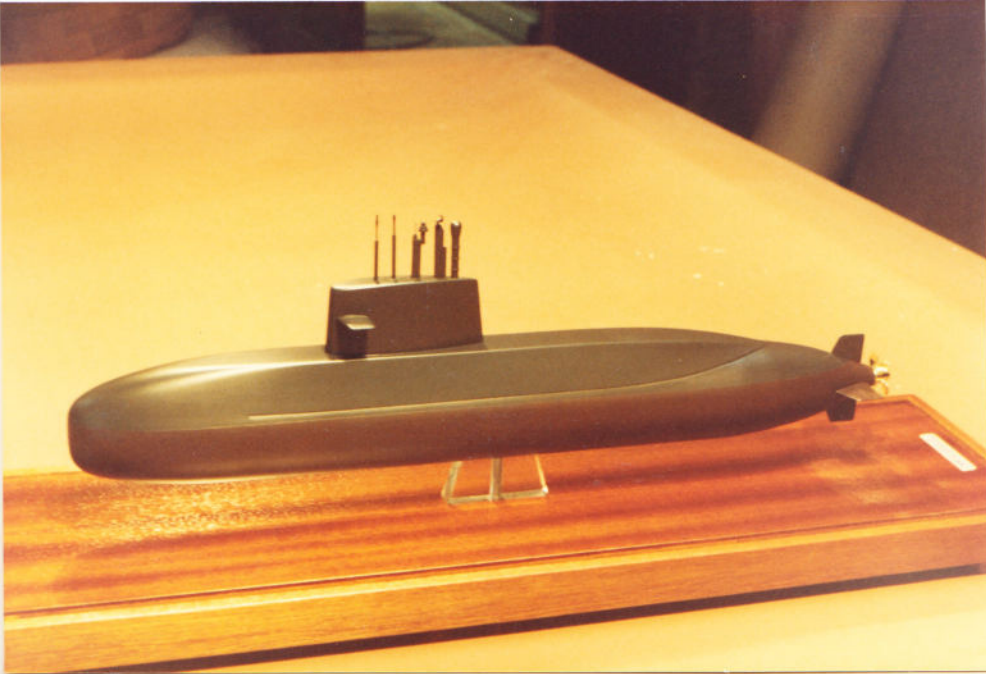

1400

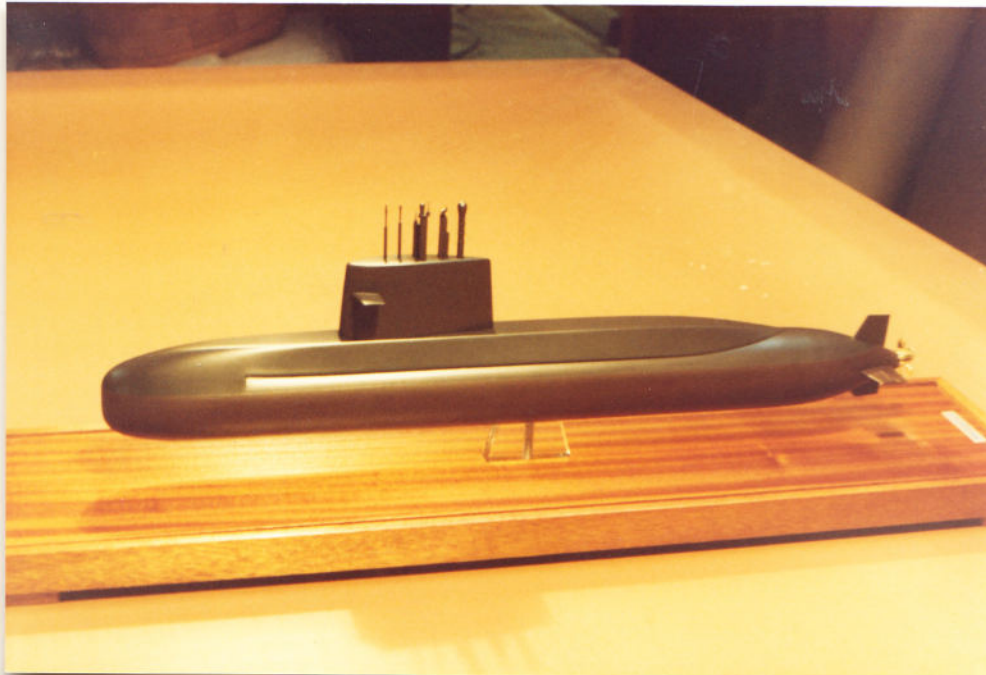

1800

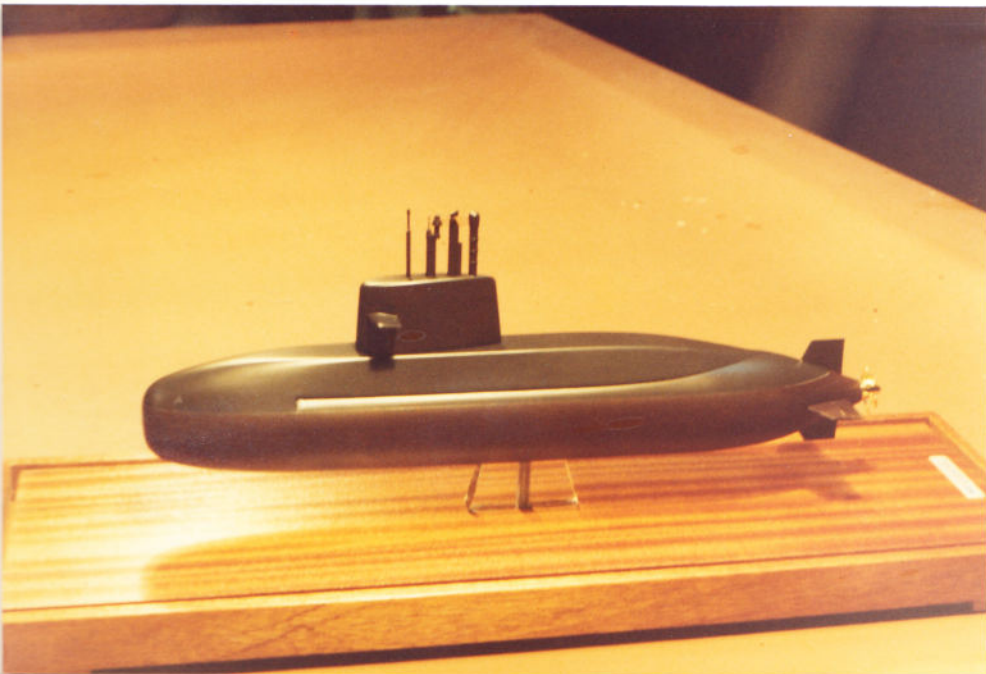

1100

2x MORAY 1100
2x MORAY 1400
2x MORAY 1800 + mat.
13 1/2 / 85 1.100
2 1/4 / 2 war.
3x MORAY 1400
1x MORAY 1100 + mat.
16 / 5 / 86 1.100
9 5 / 2 war.
3x MORAY 1400 + mat.
7 / 6 / 85 1.100
104 war.

1800

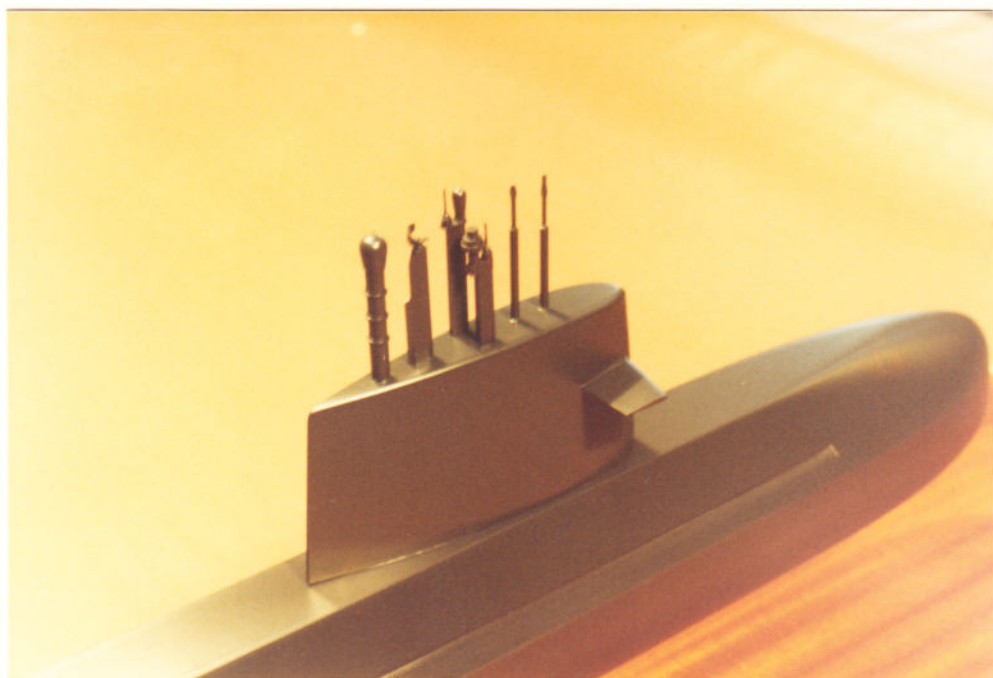

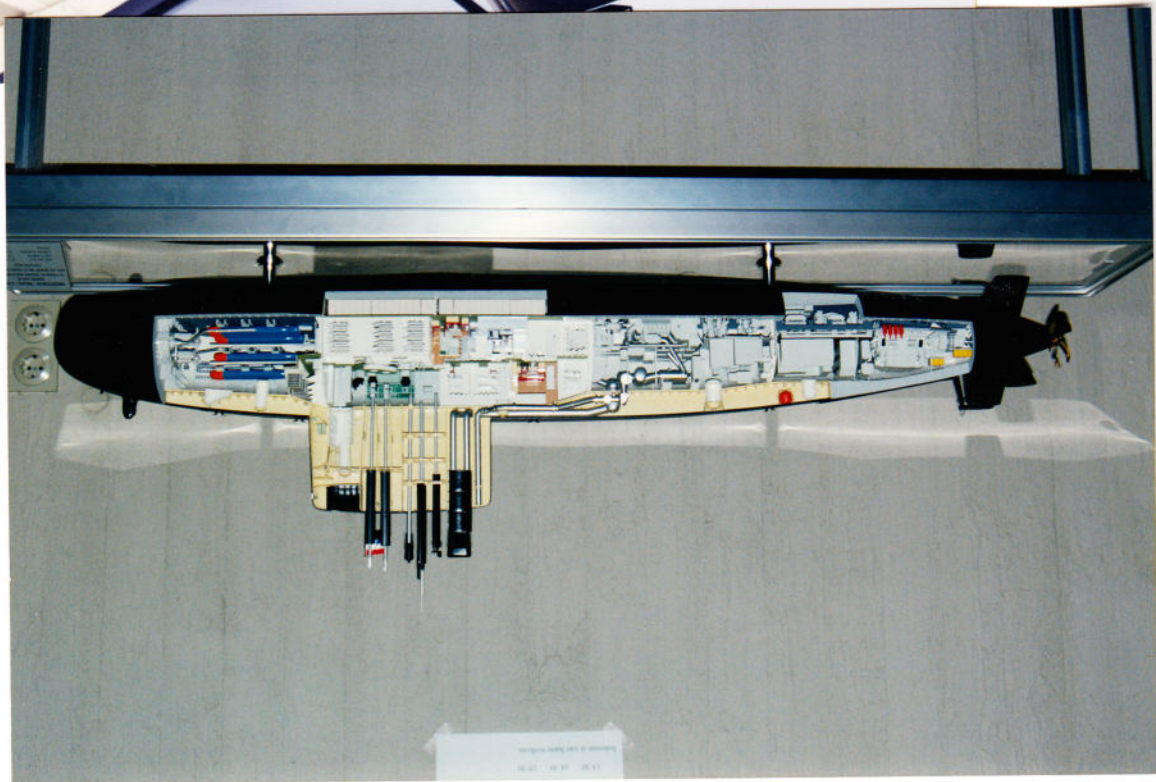
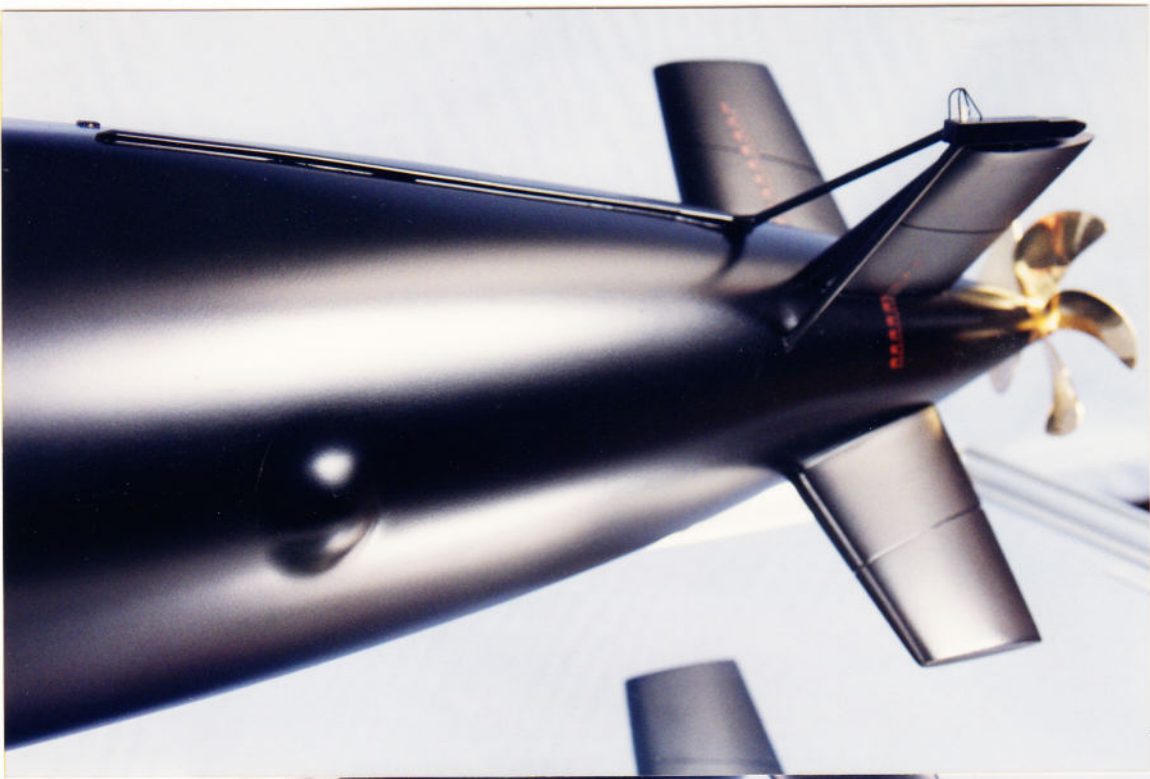

U-100

(Kees Leijter)
(Piet Weisfelt)

5/12/92

2 van der Zee's

1:50

MARINE

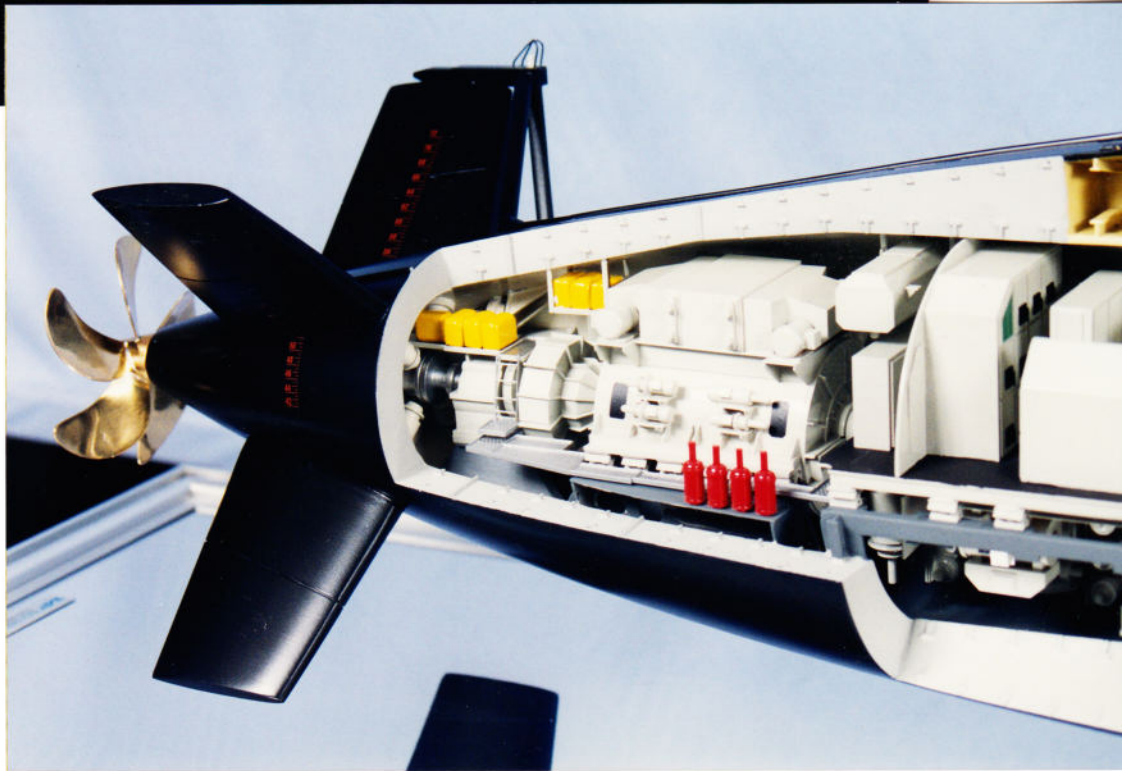
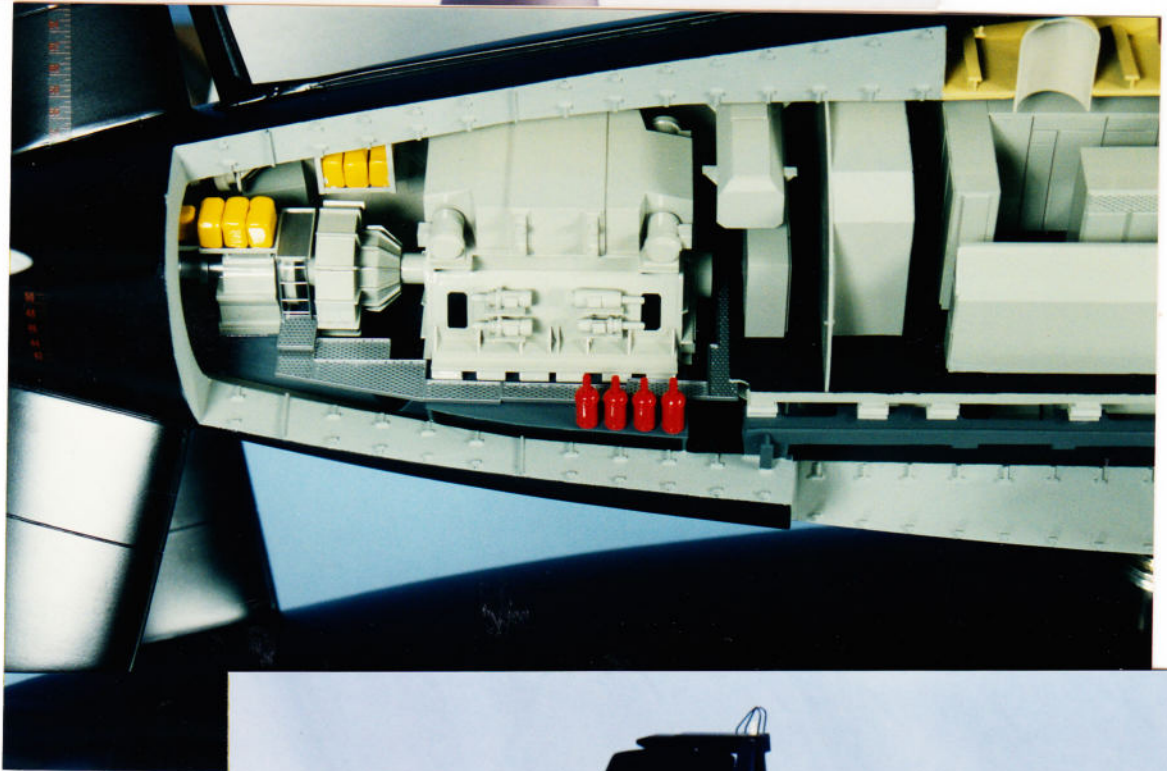
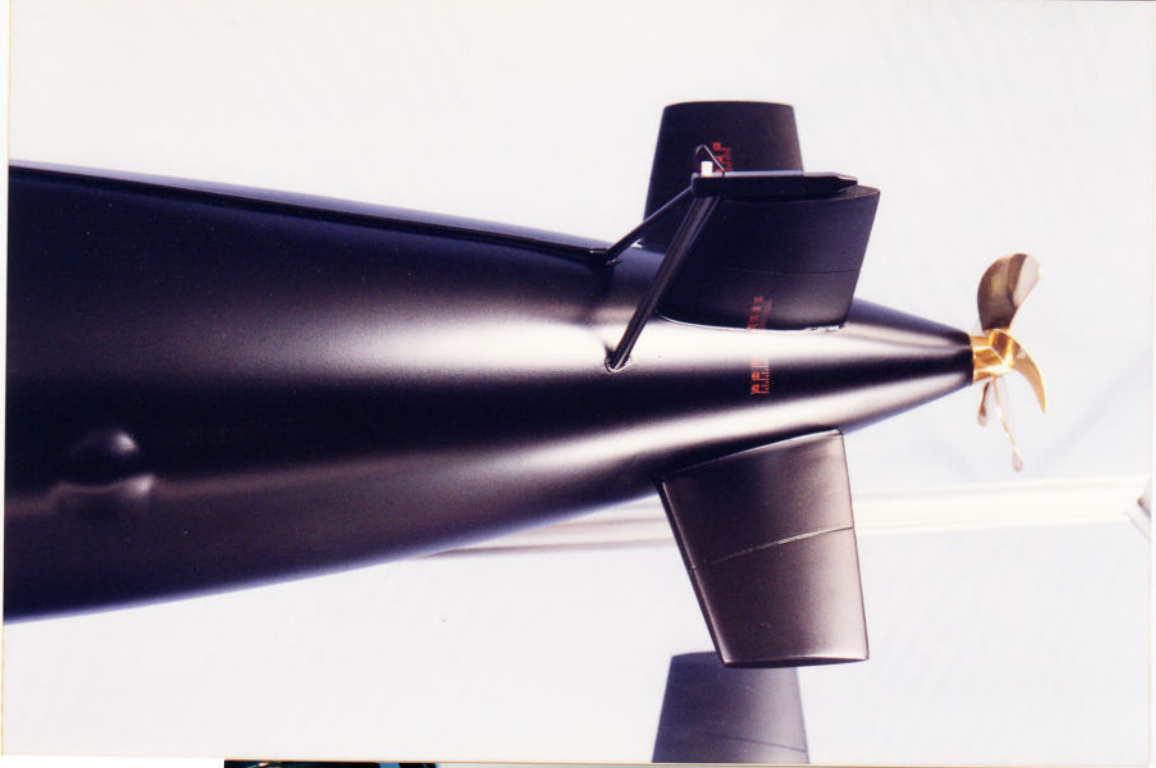

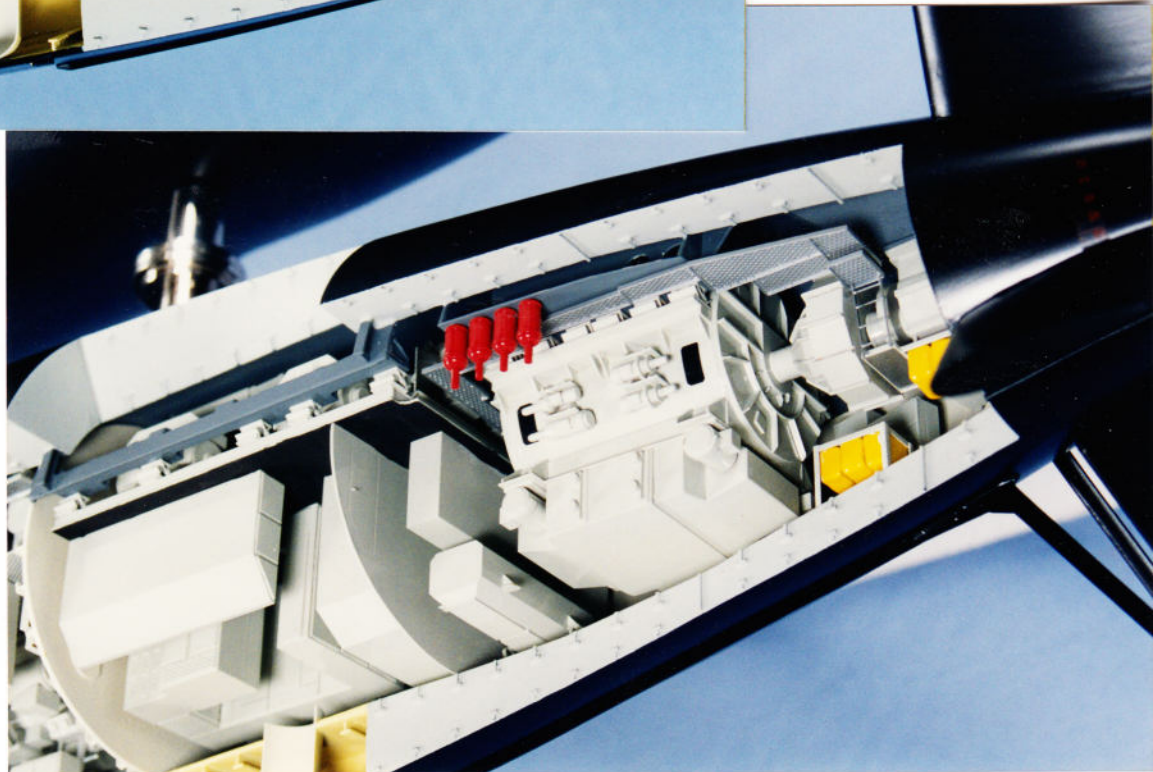
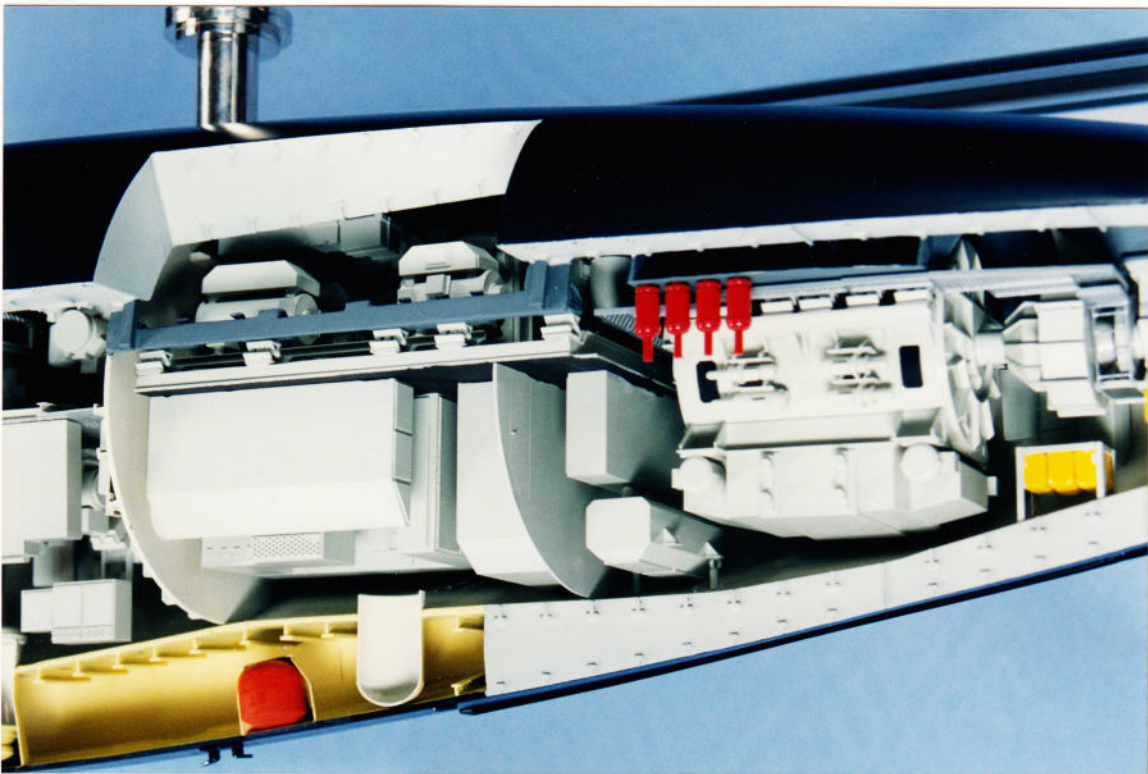
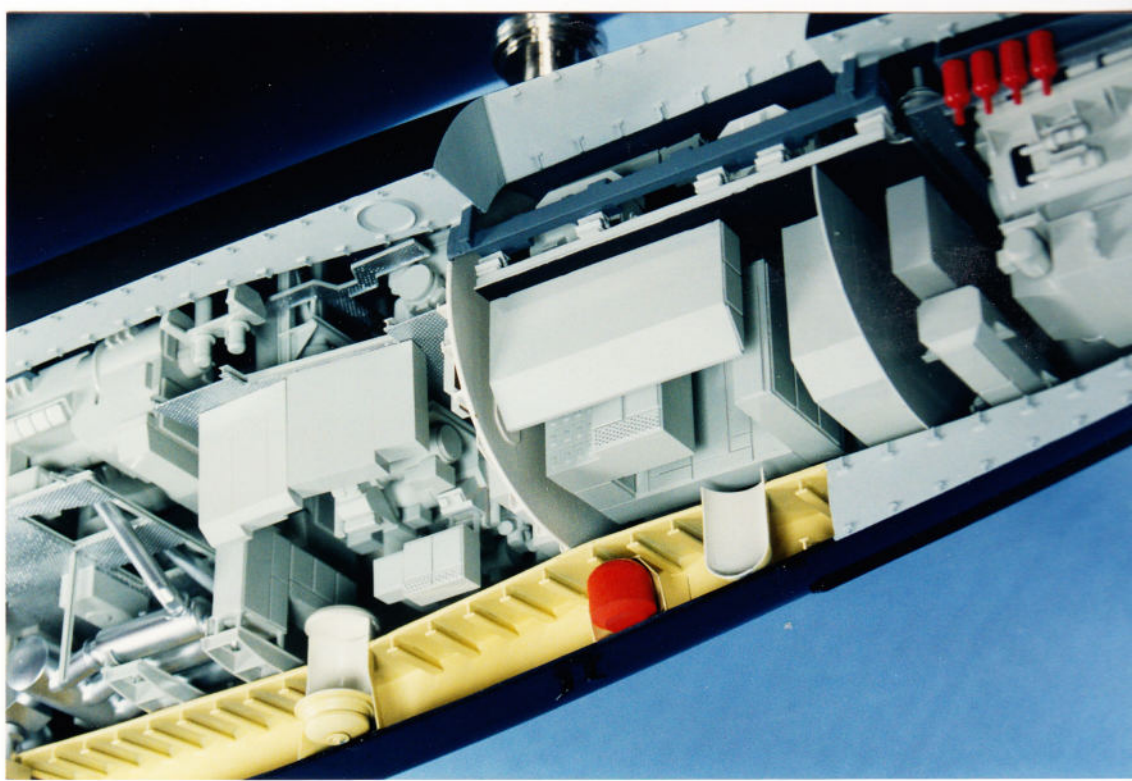

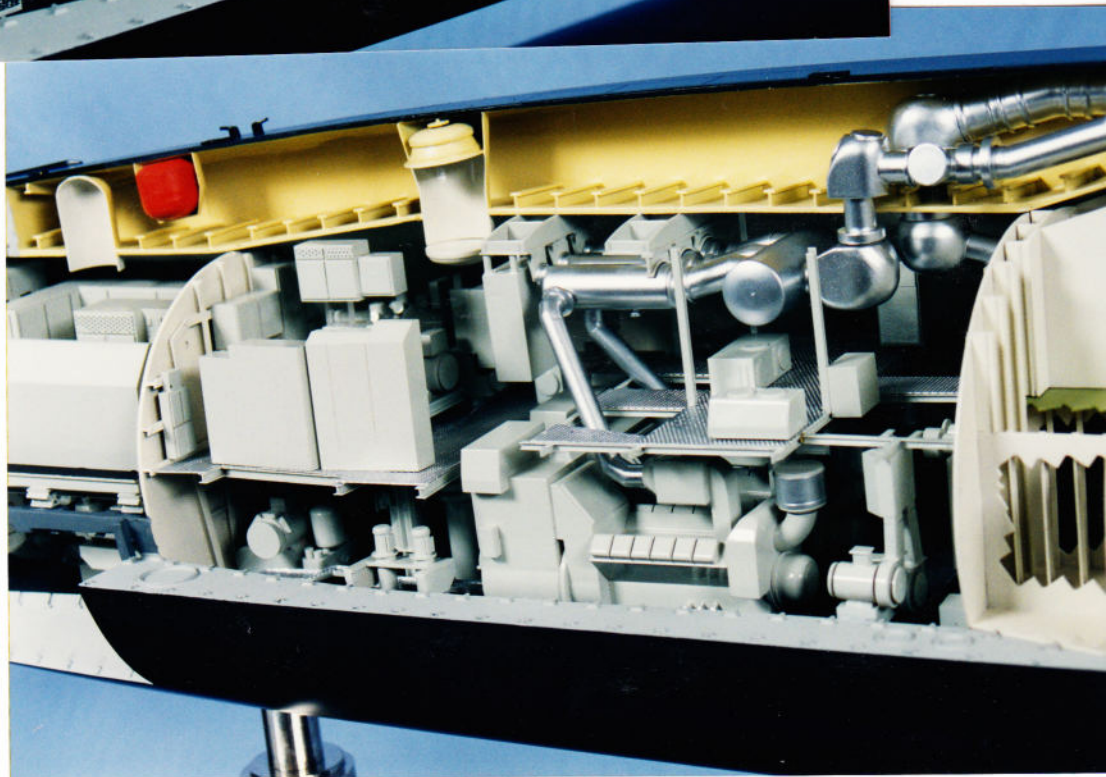
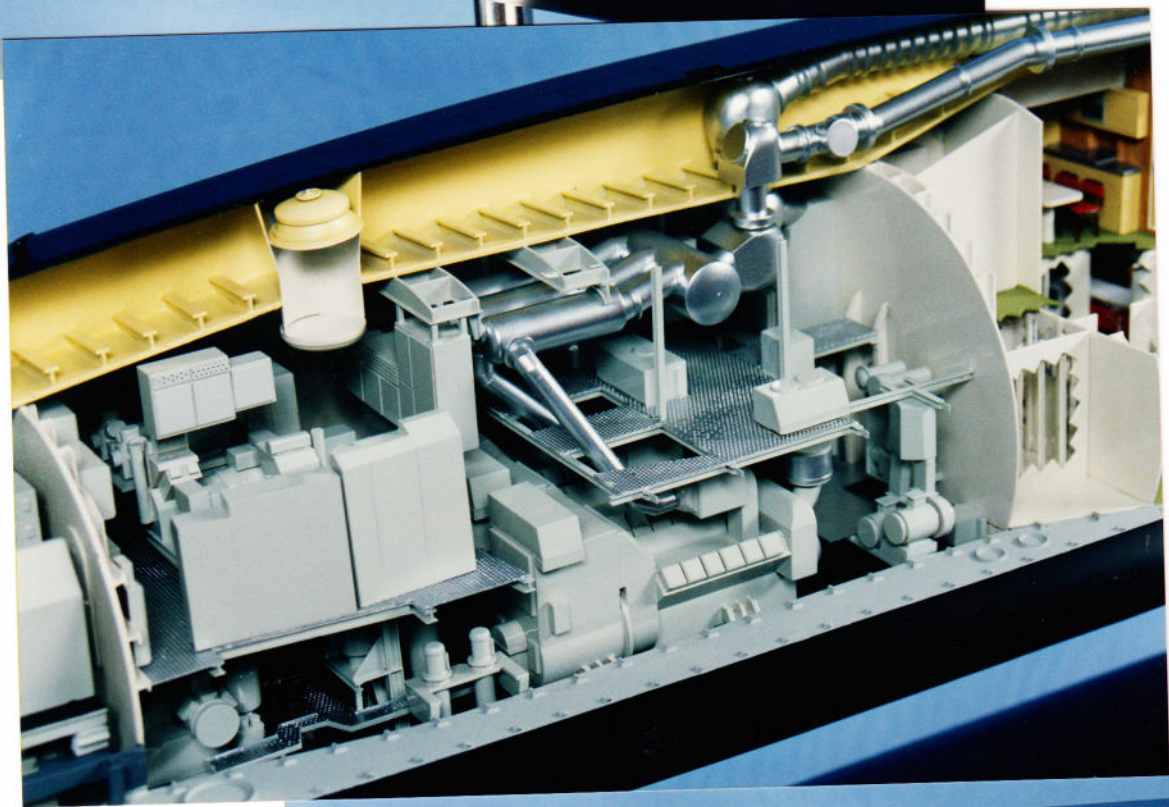
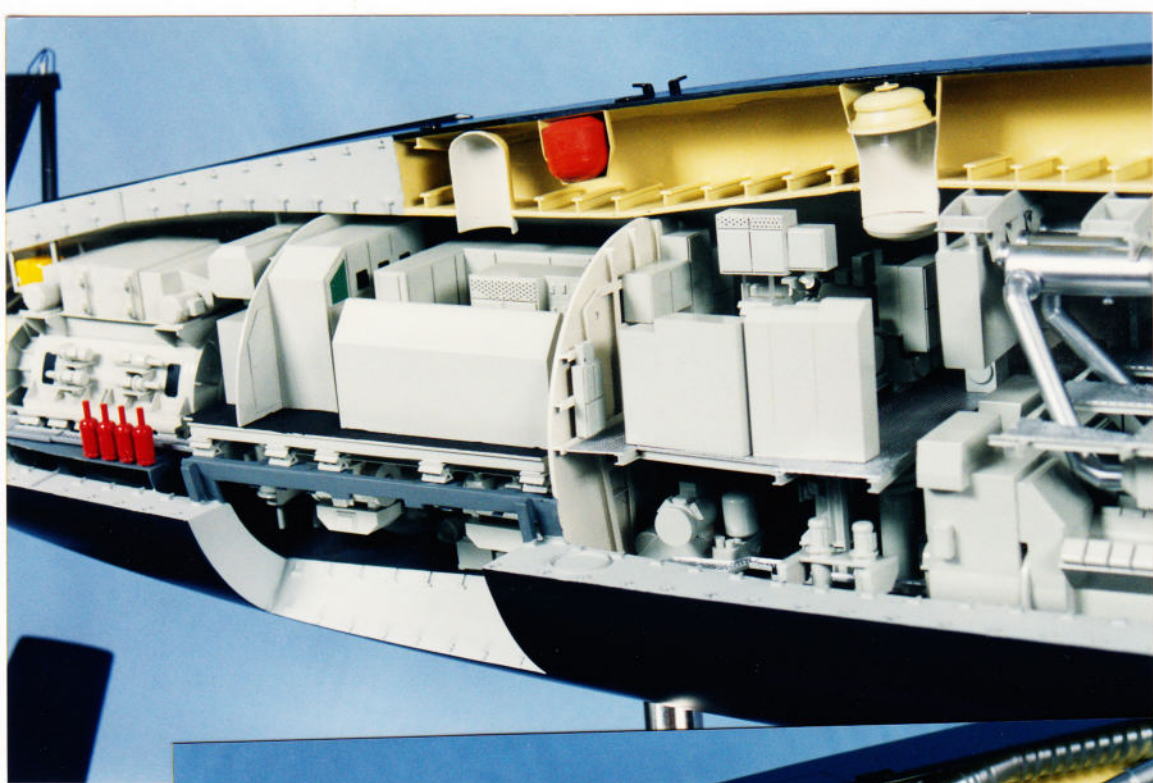

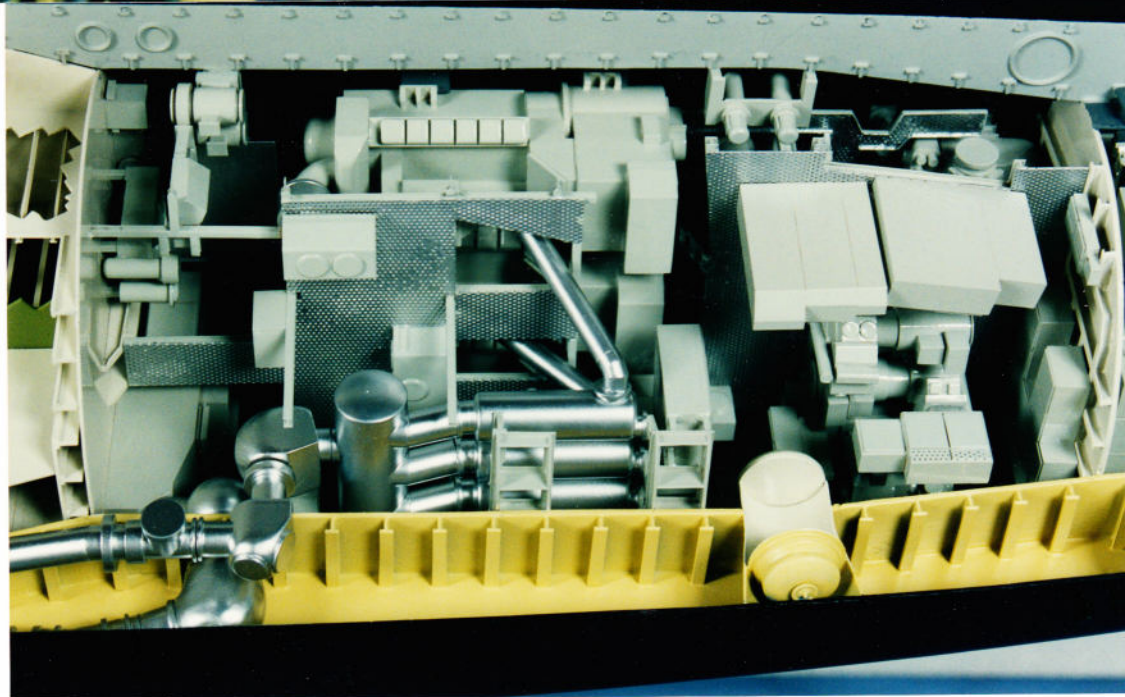
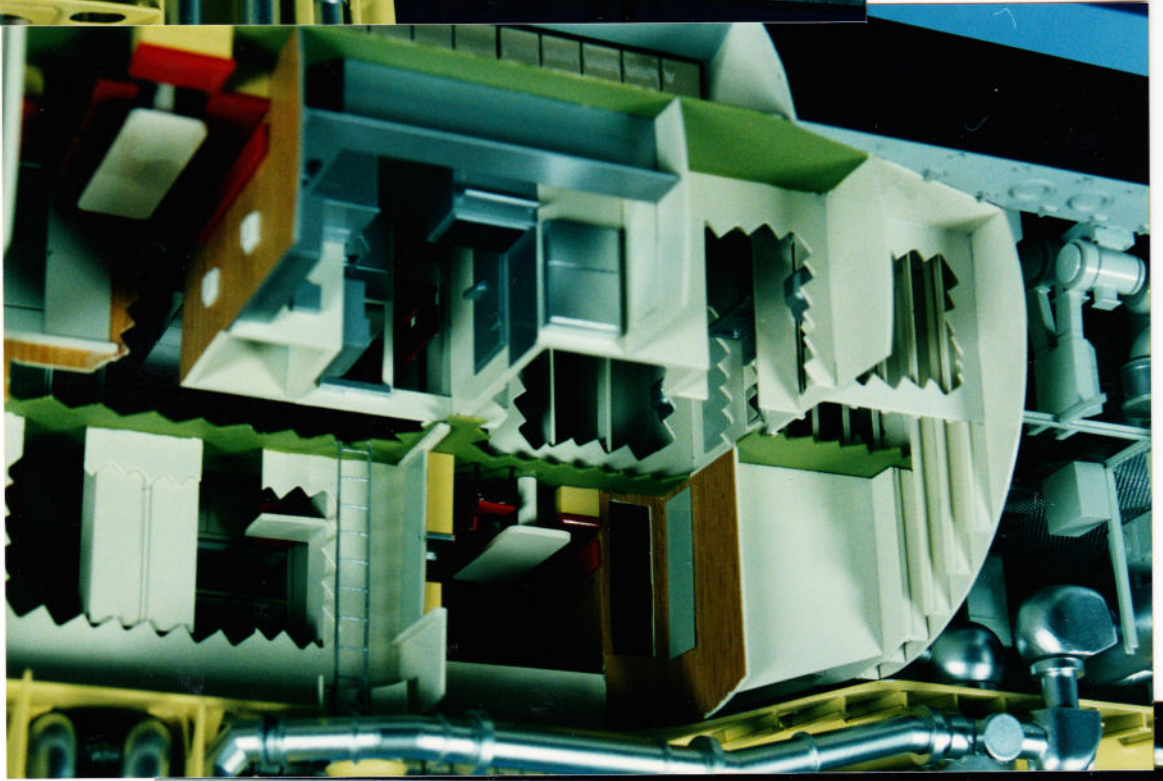
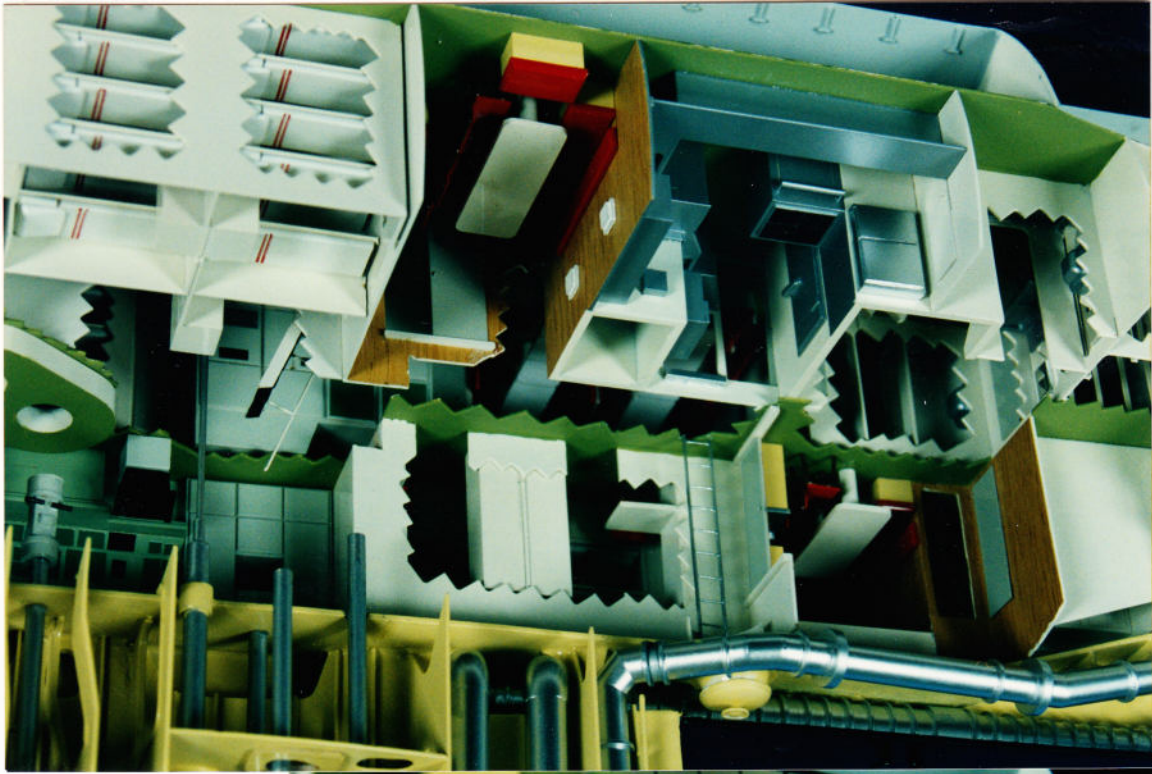

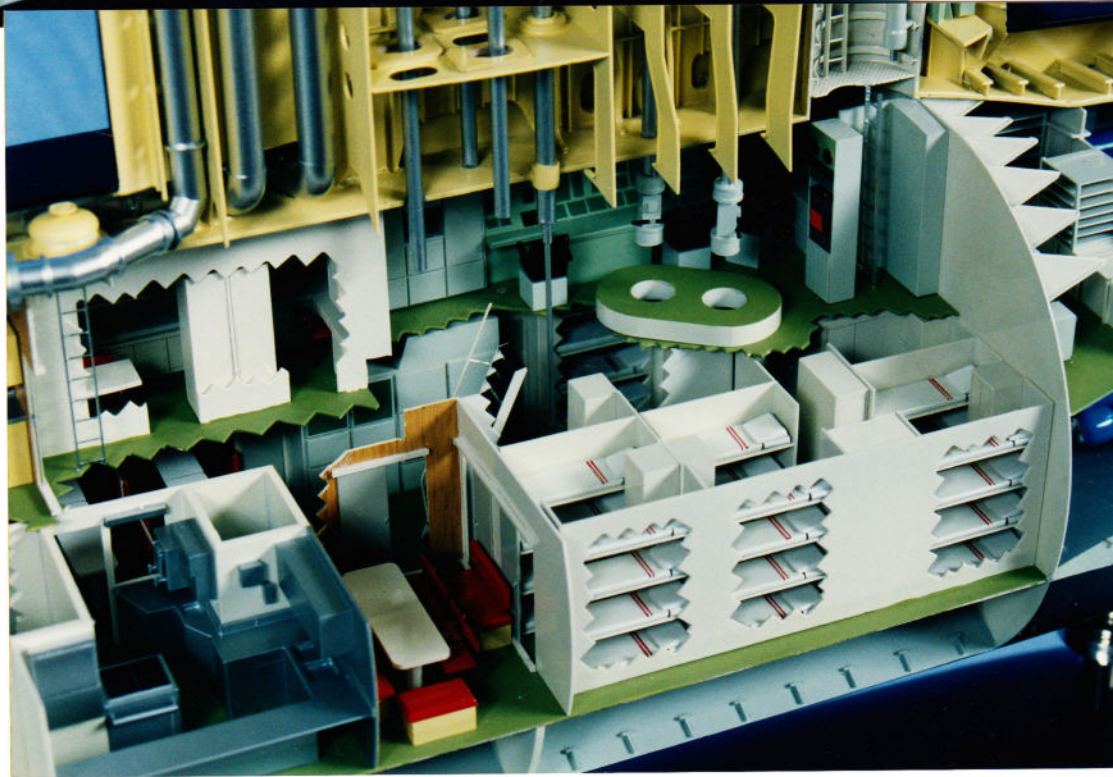
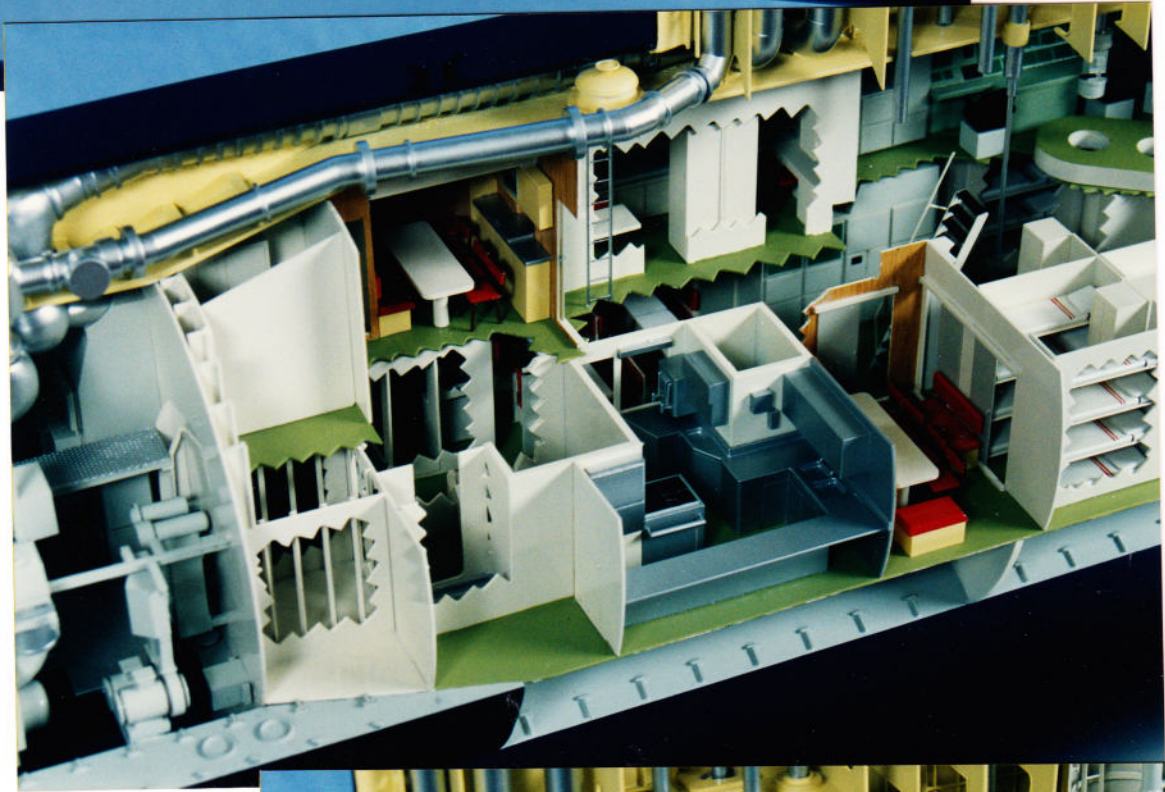
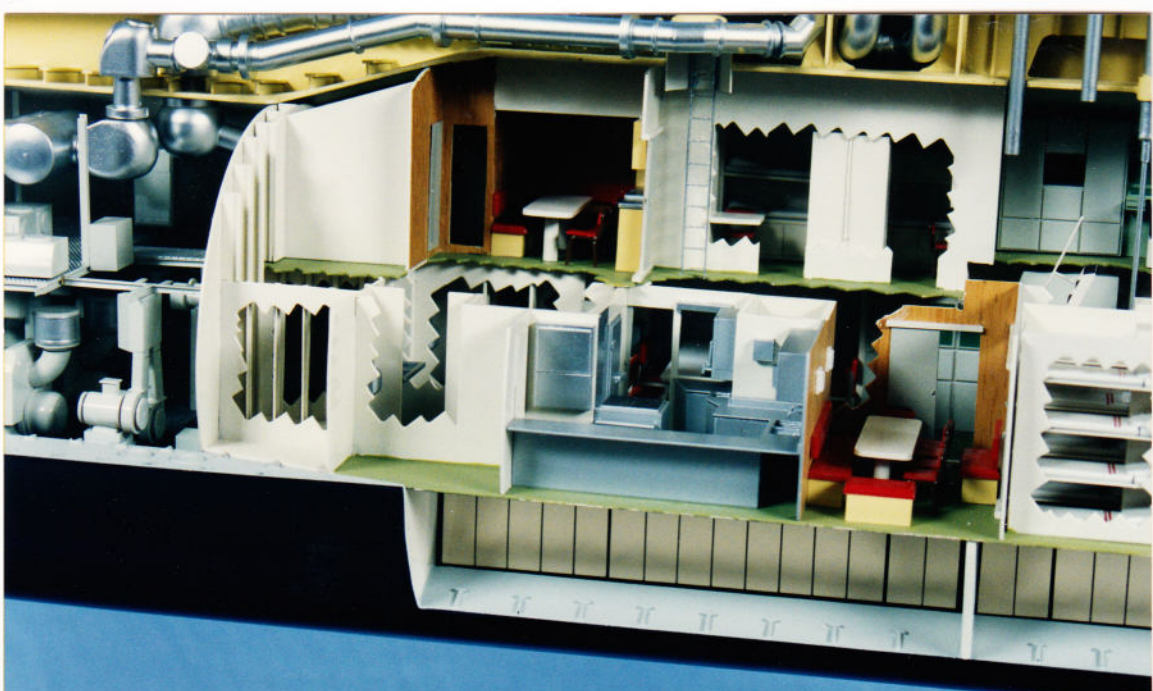

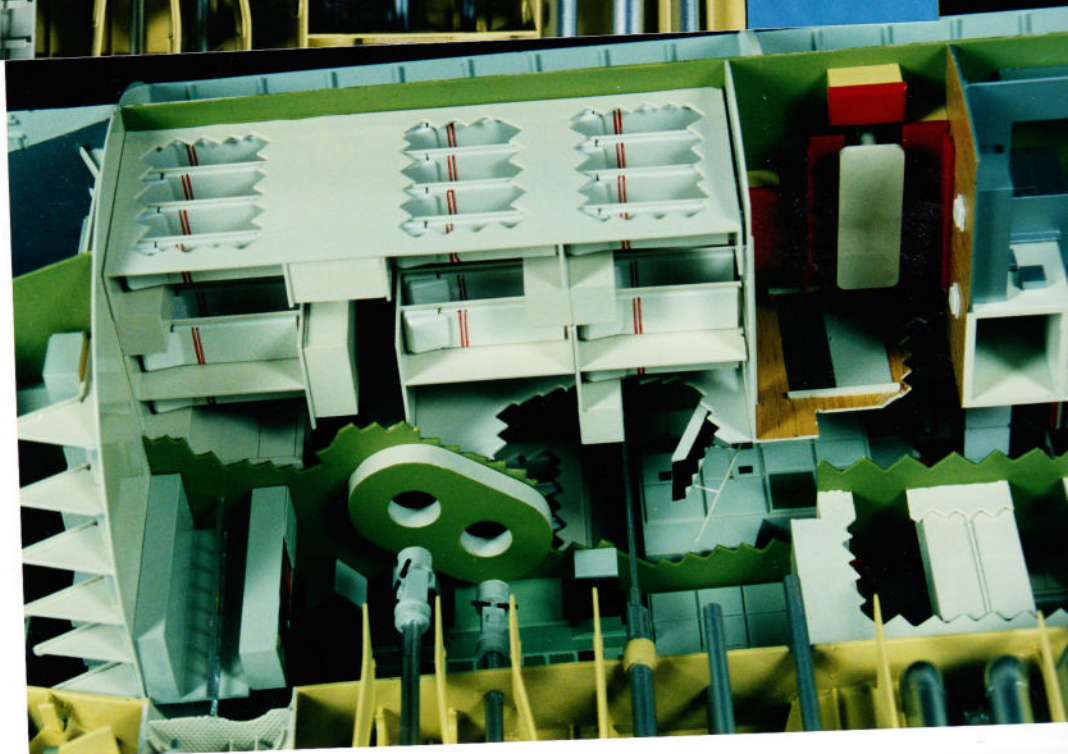

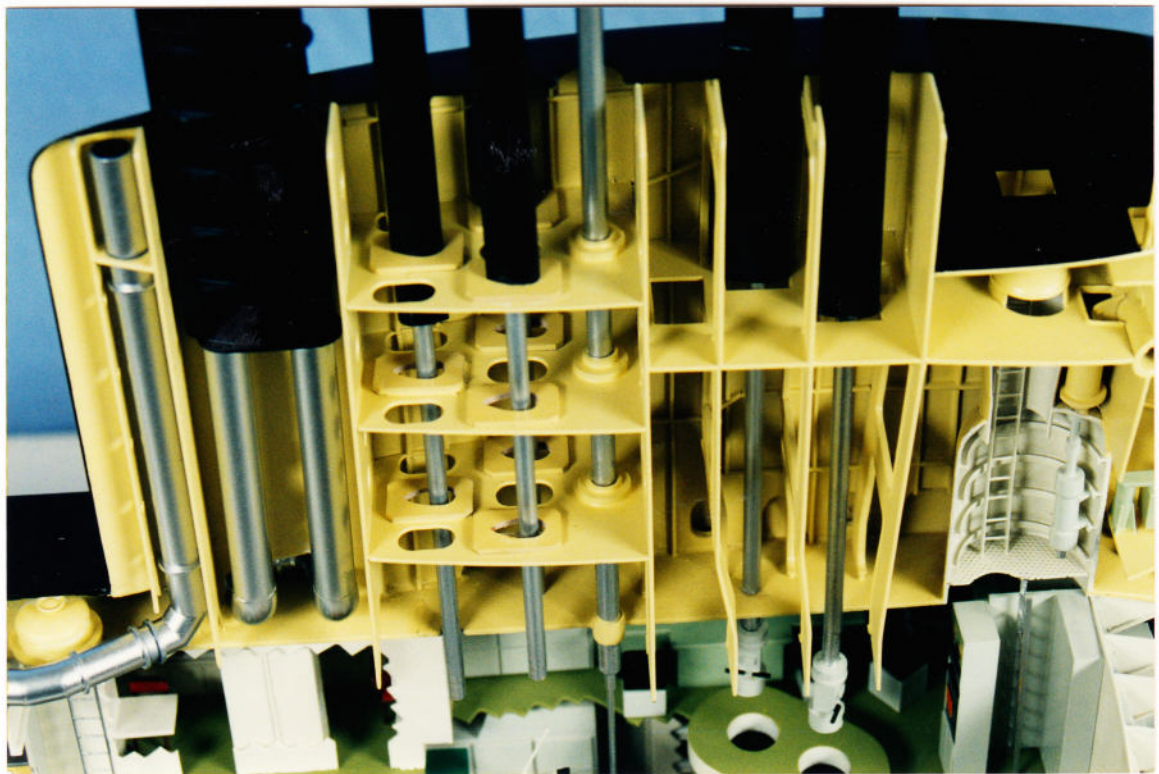
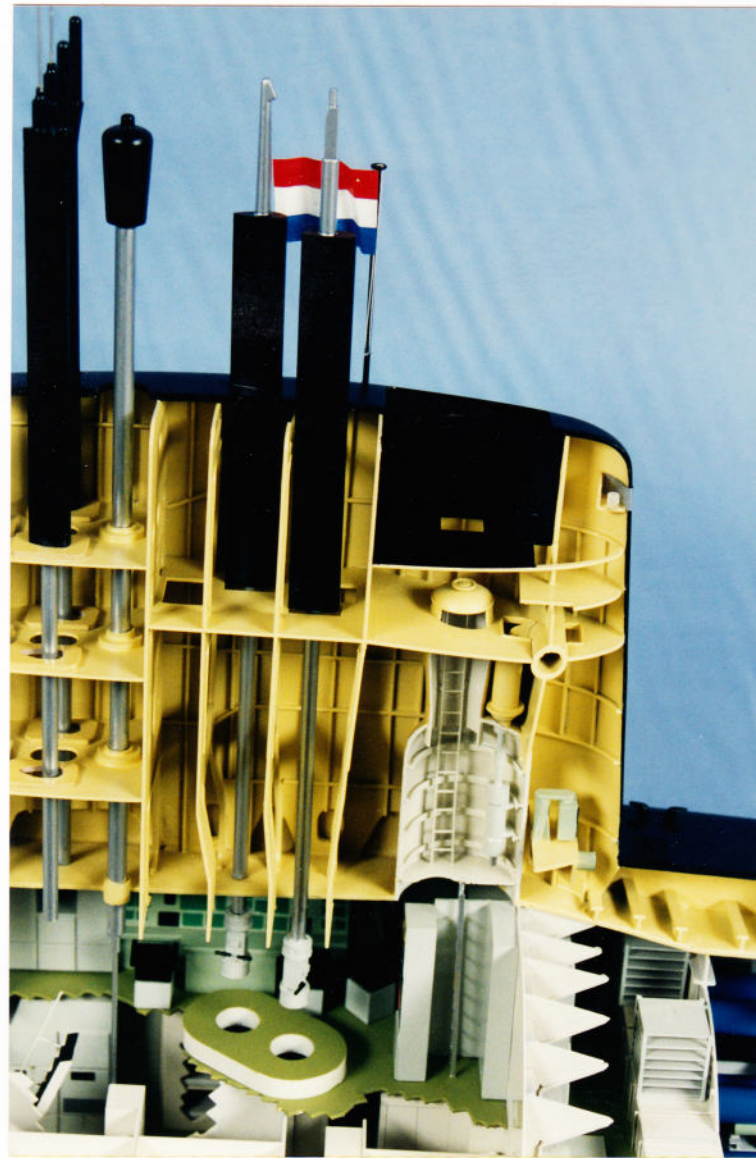
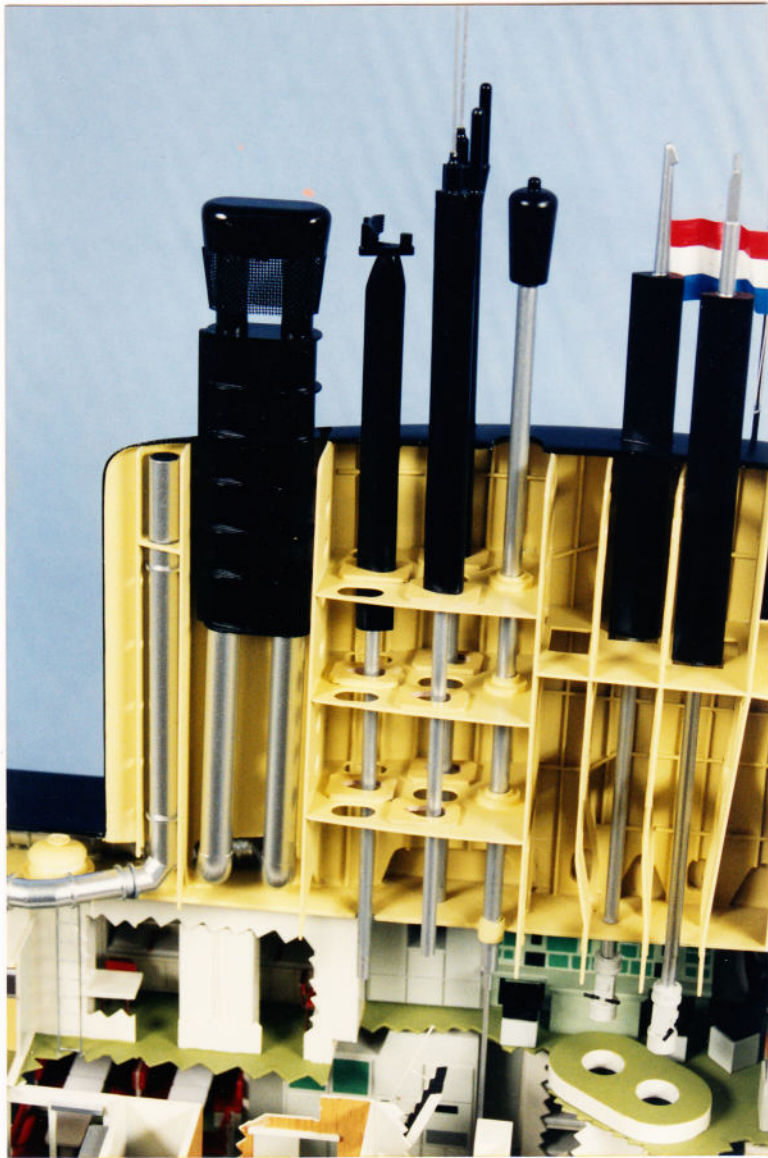

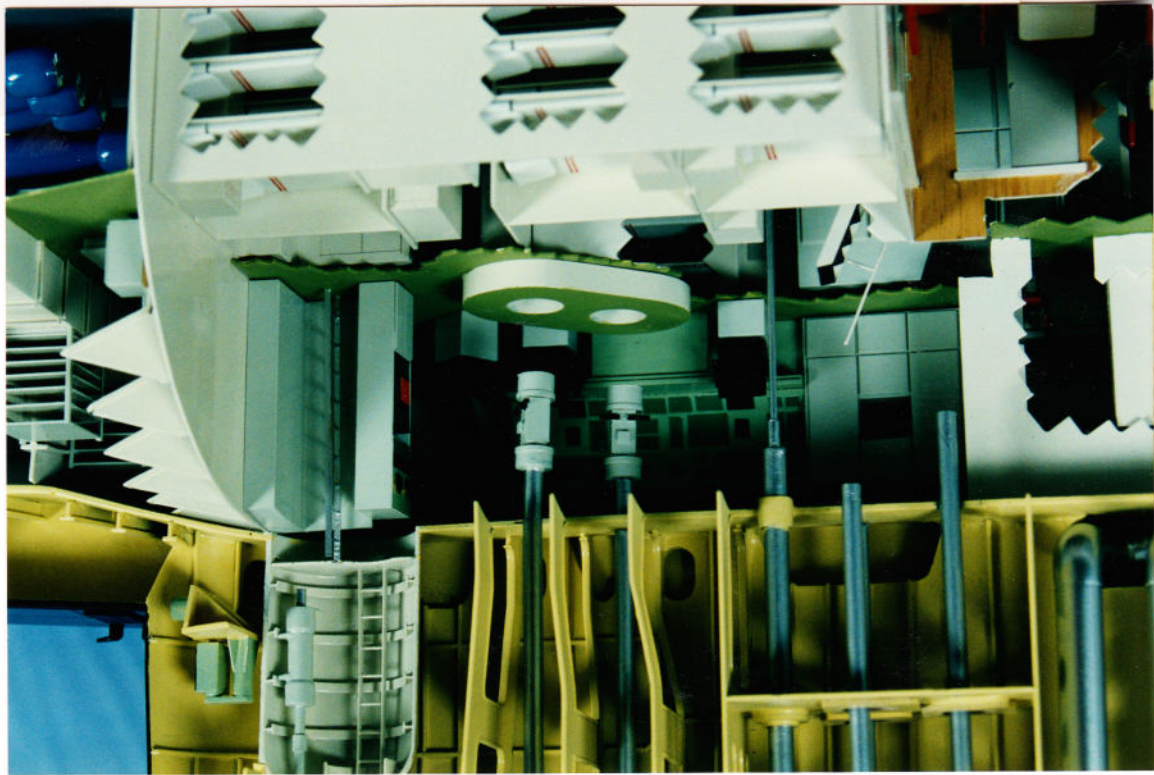
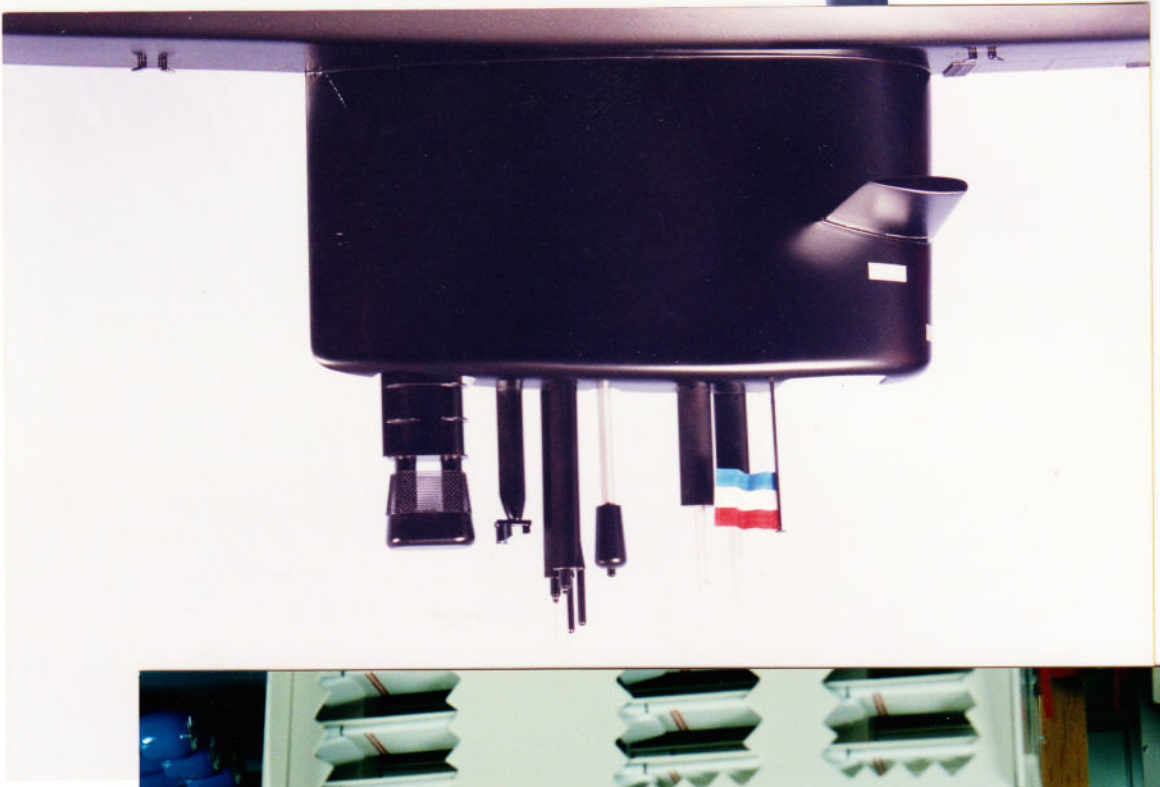
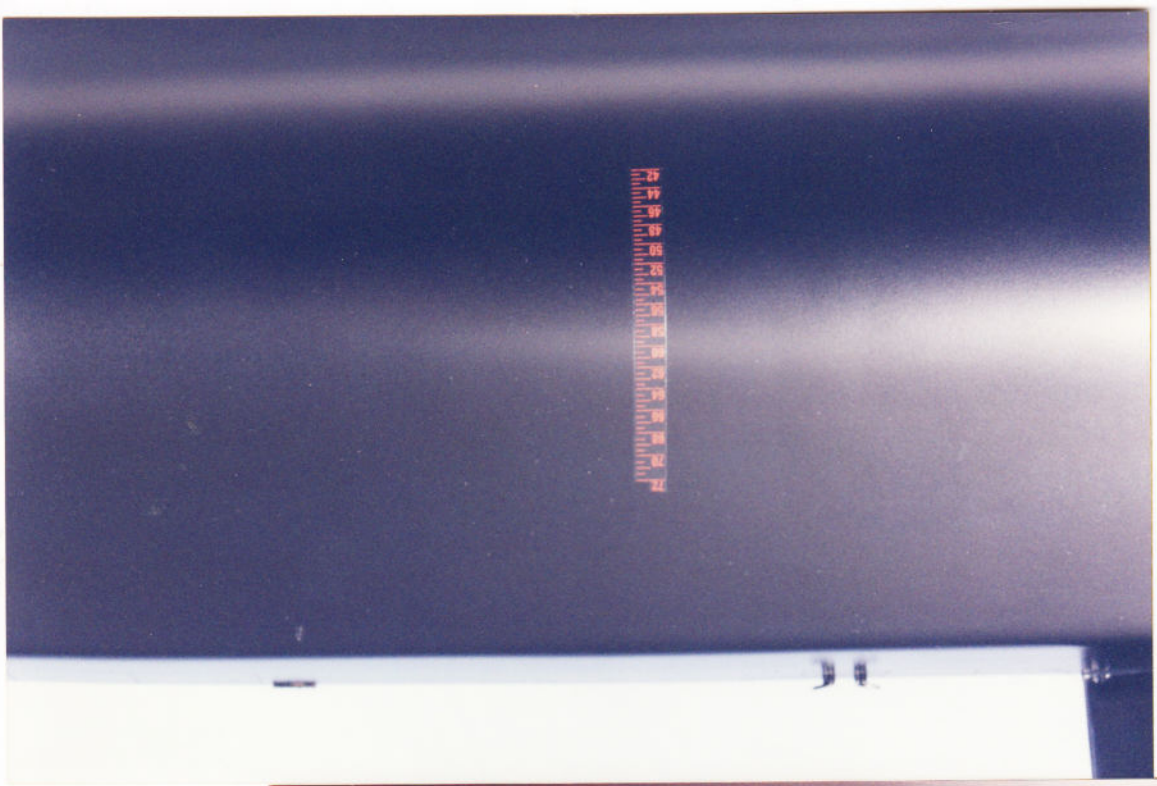

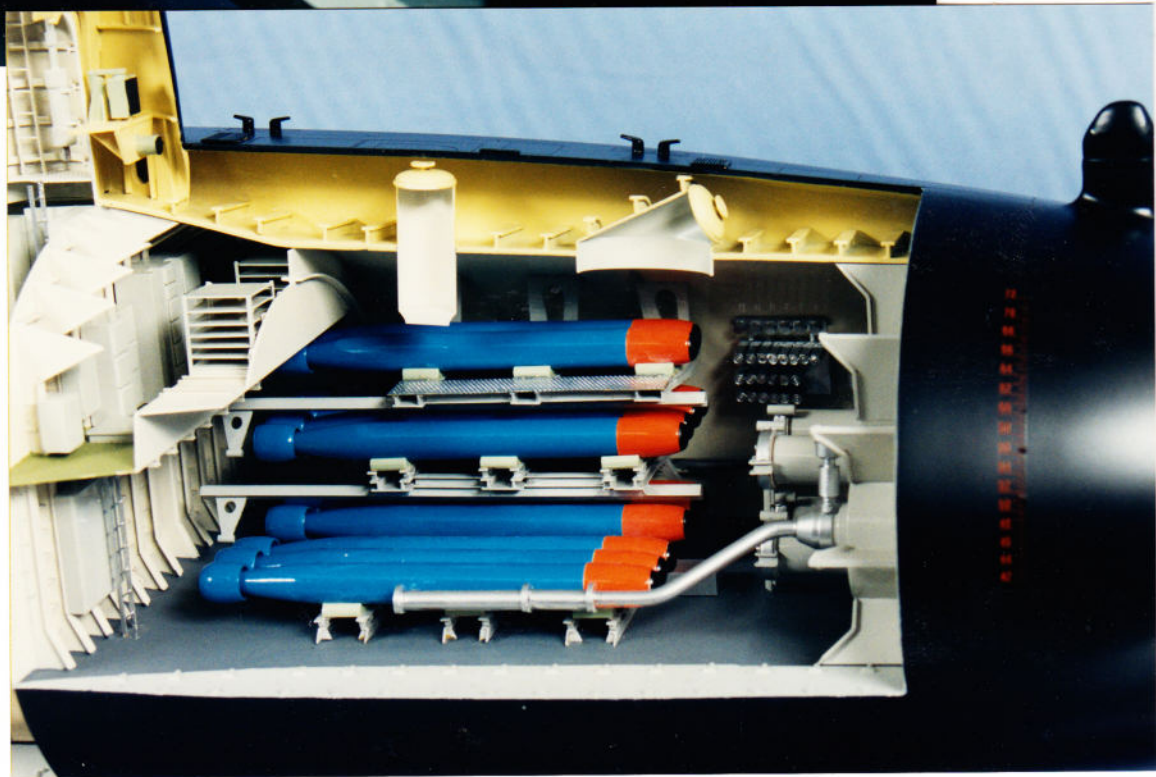
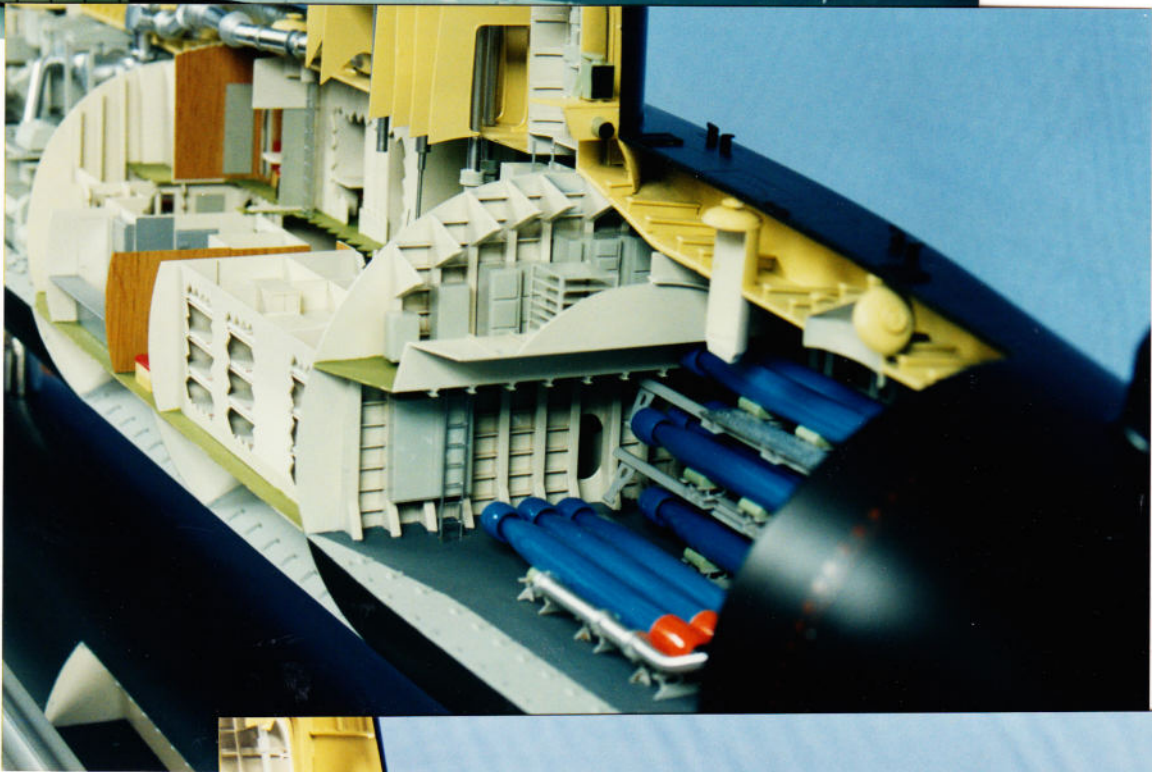
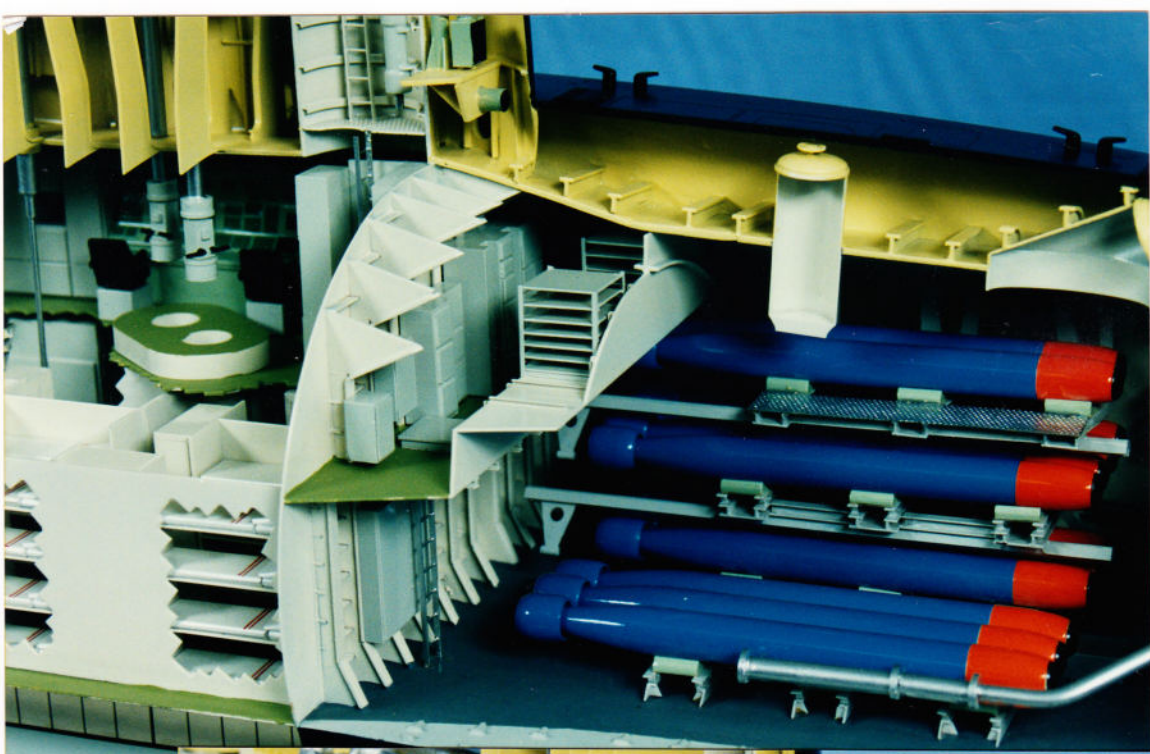

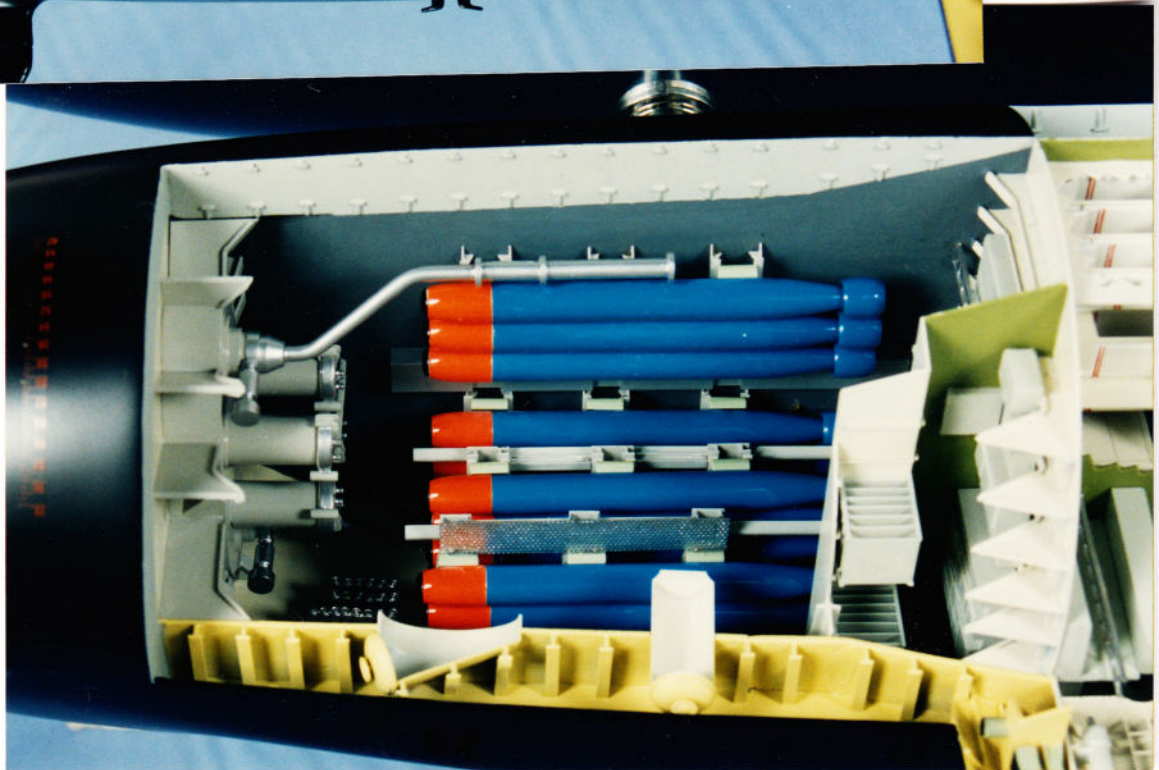
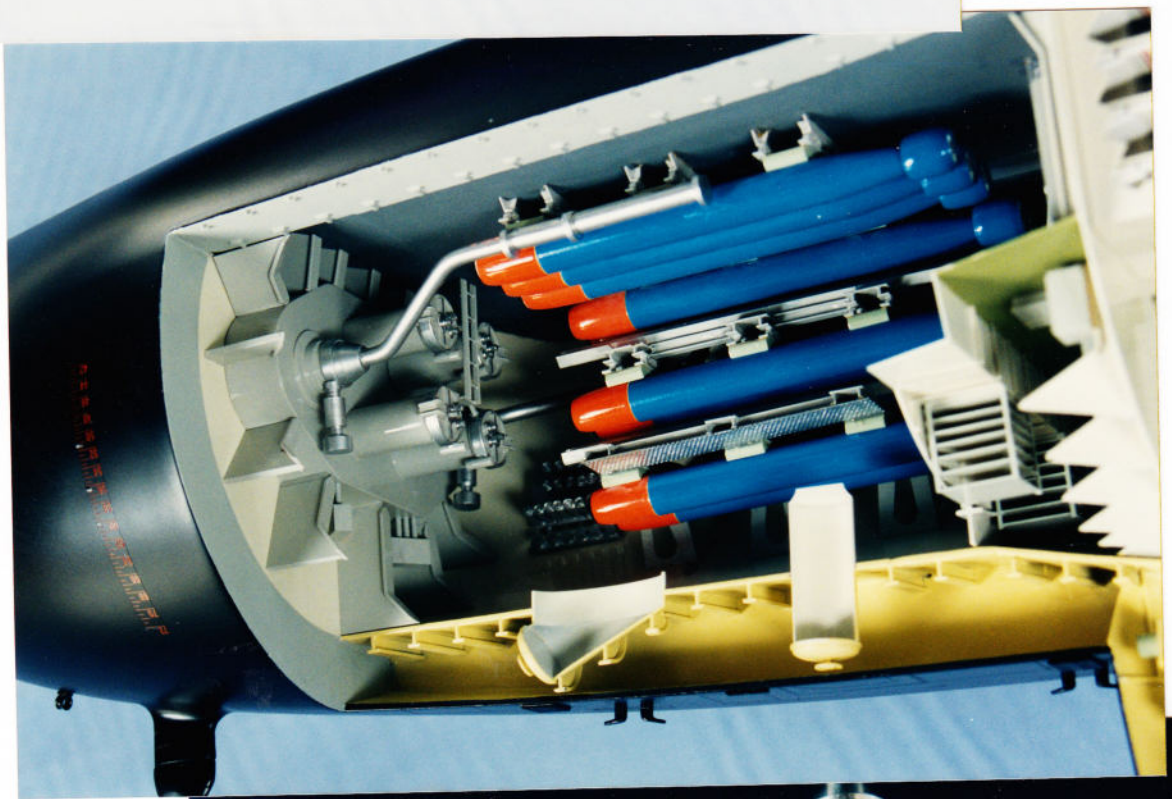



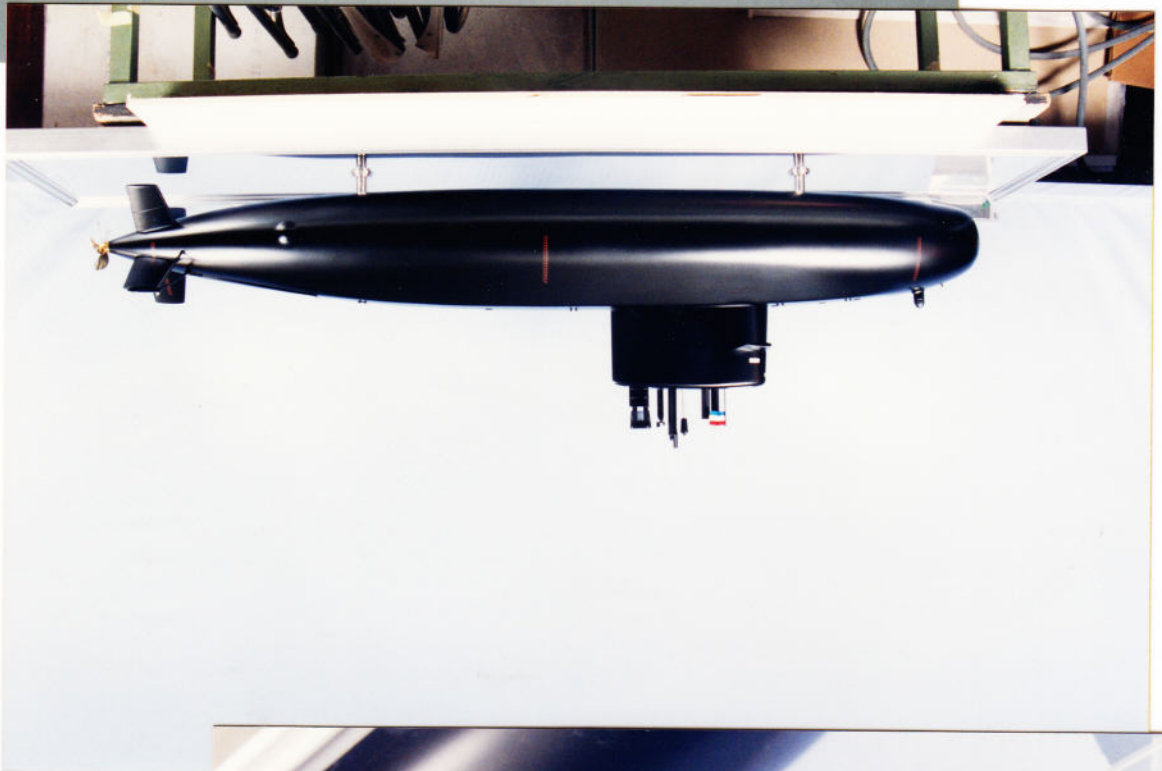
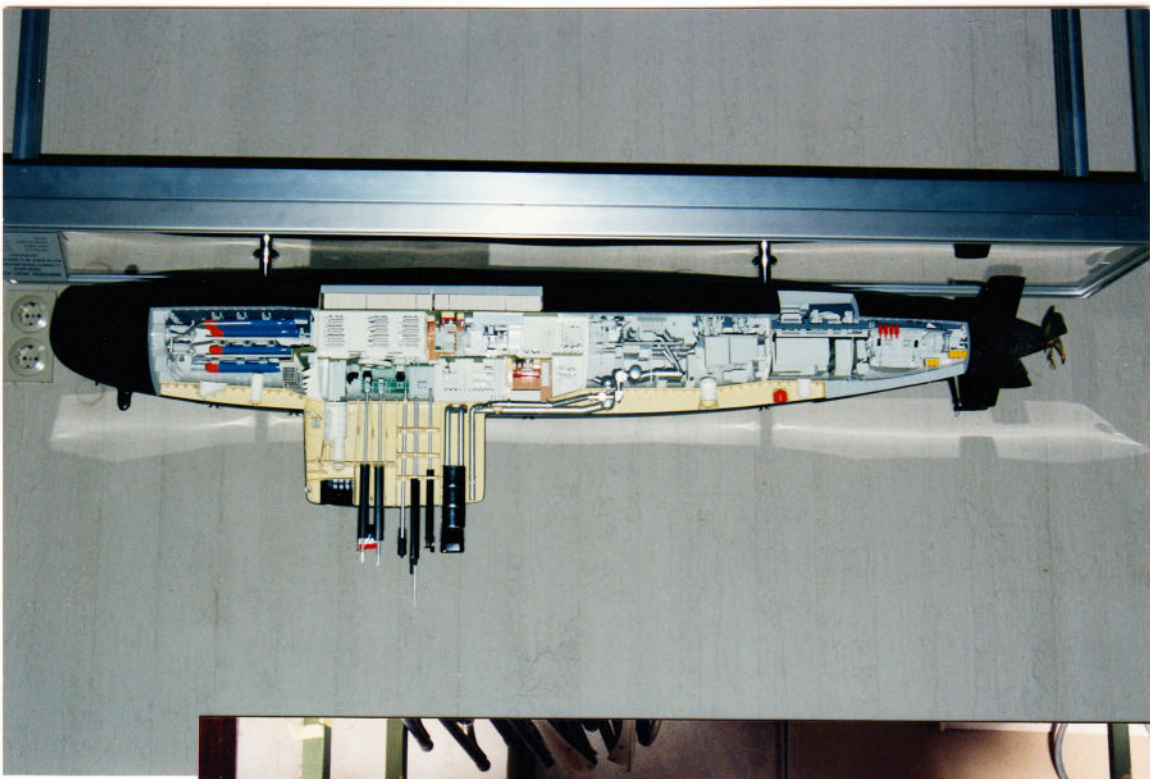

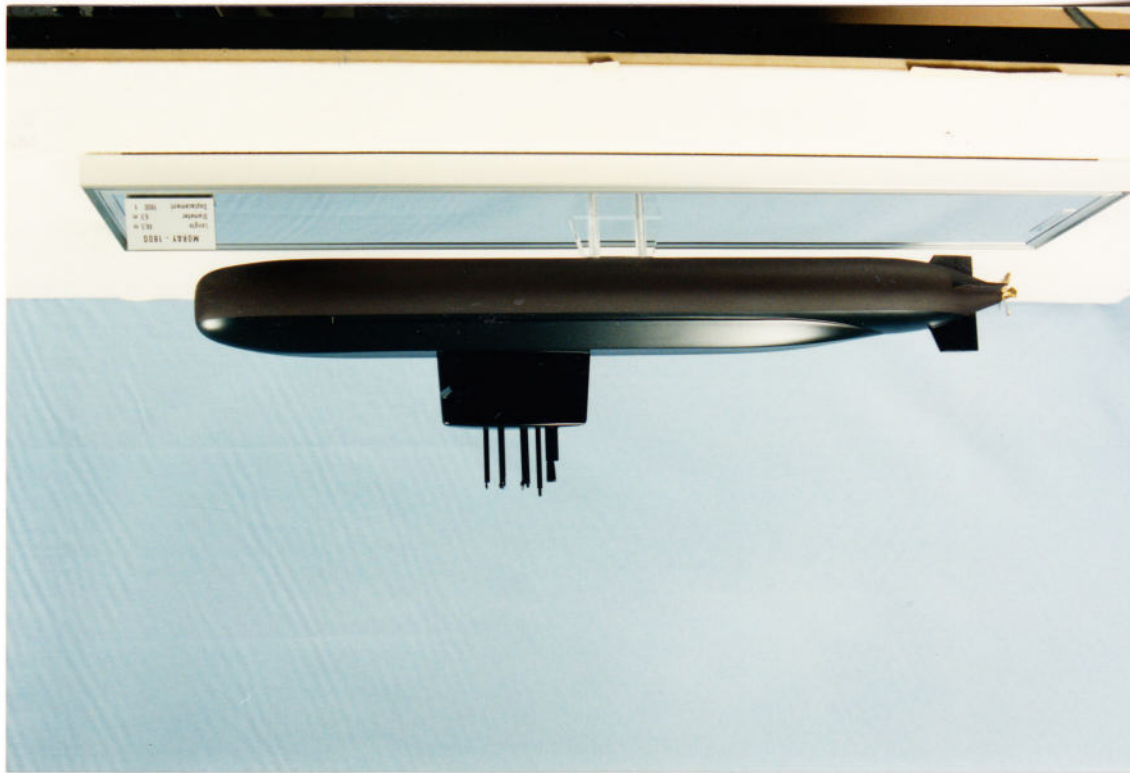

RDM
 1:100
 S modelen
 MORAY 1800
 19/1/93
 1/2 uen.

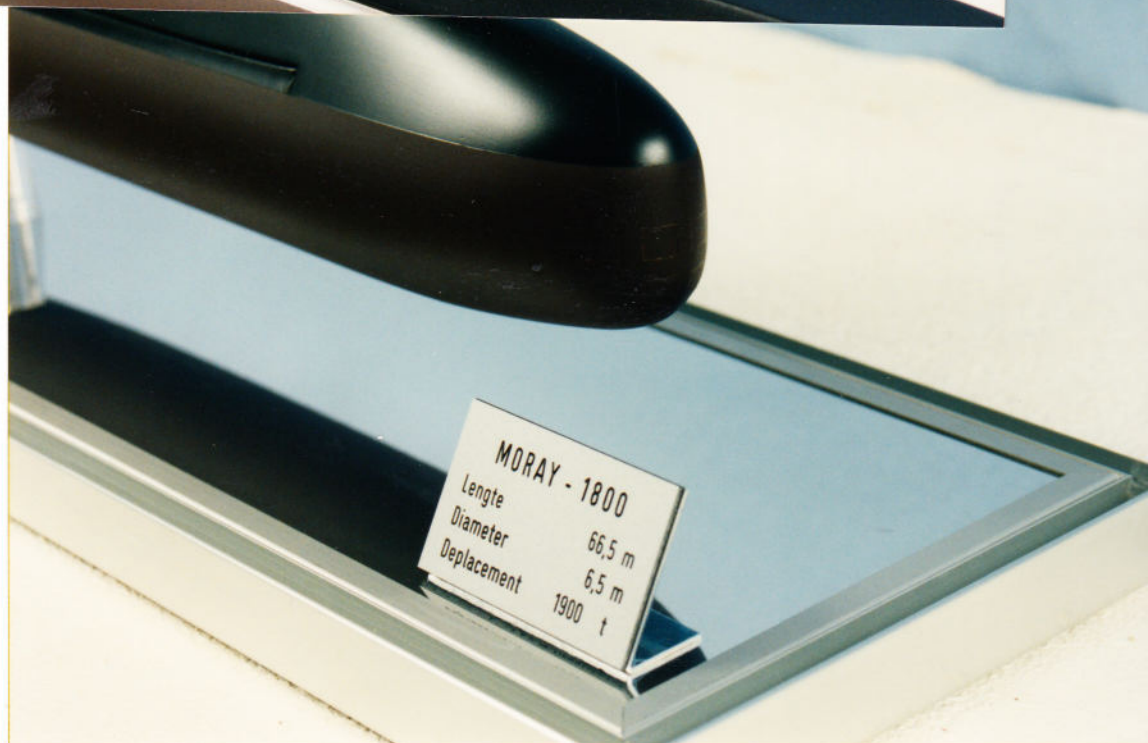
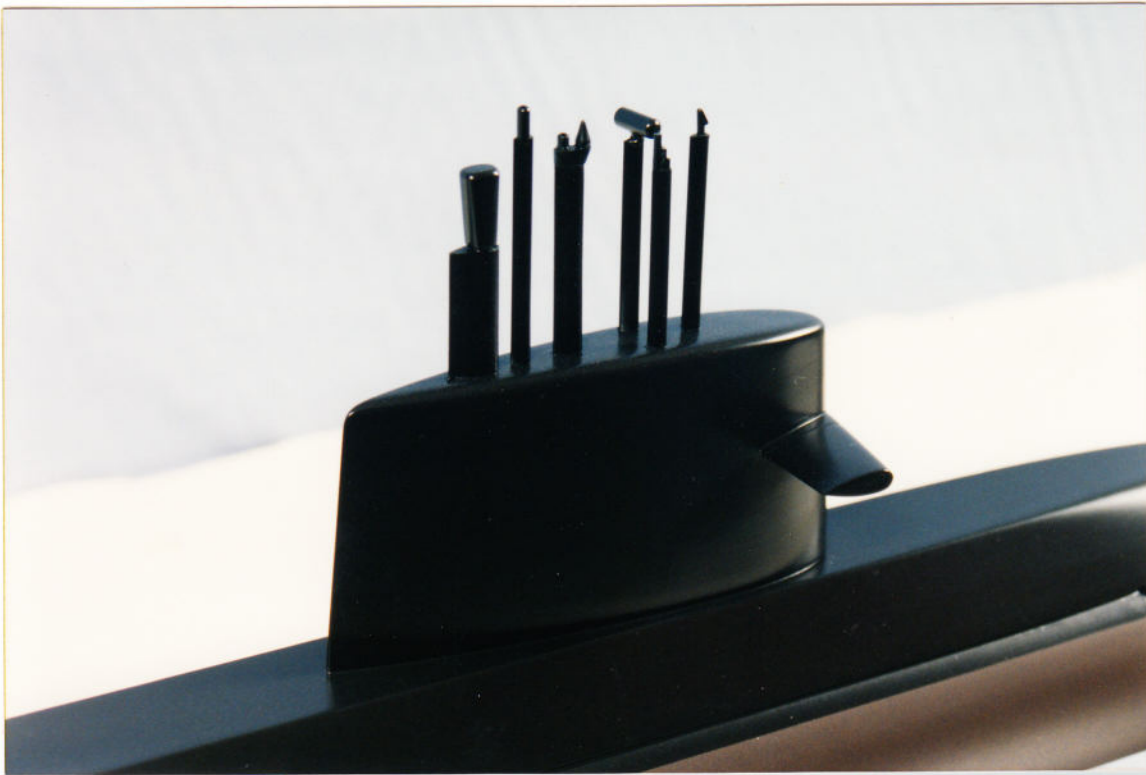

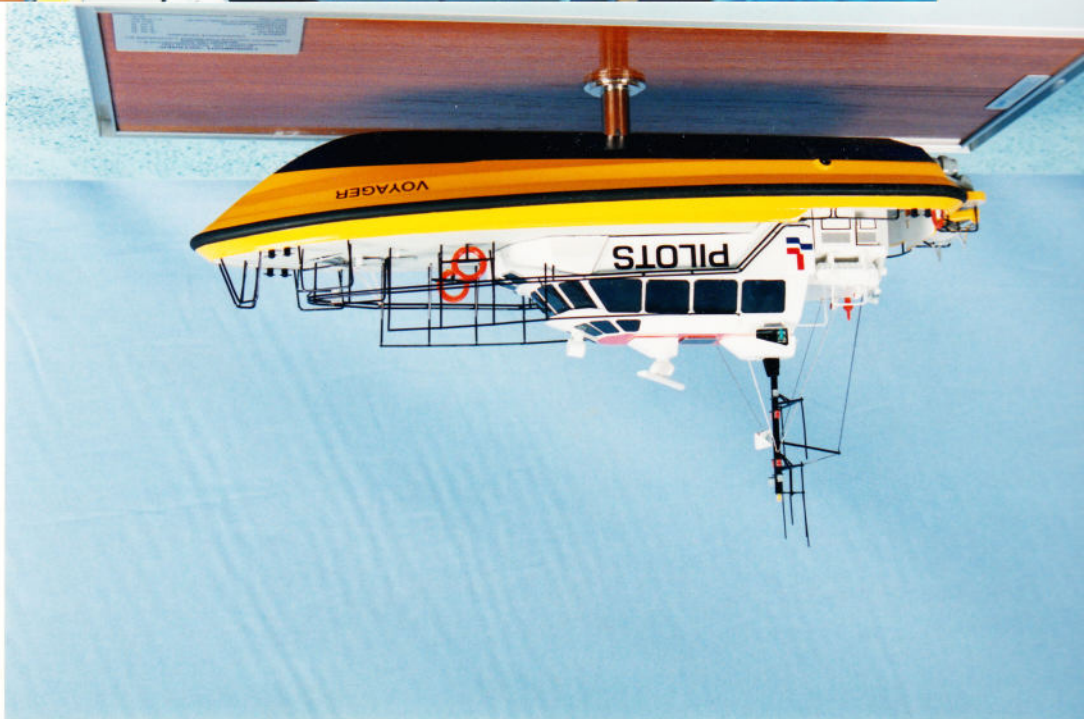

"VOYAGER"
 ENGELER BV
 LOODSBOOT
 1:50
 23-9-94
 147 mm.



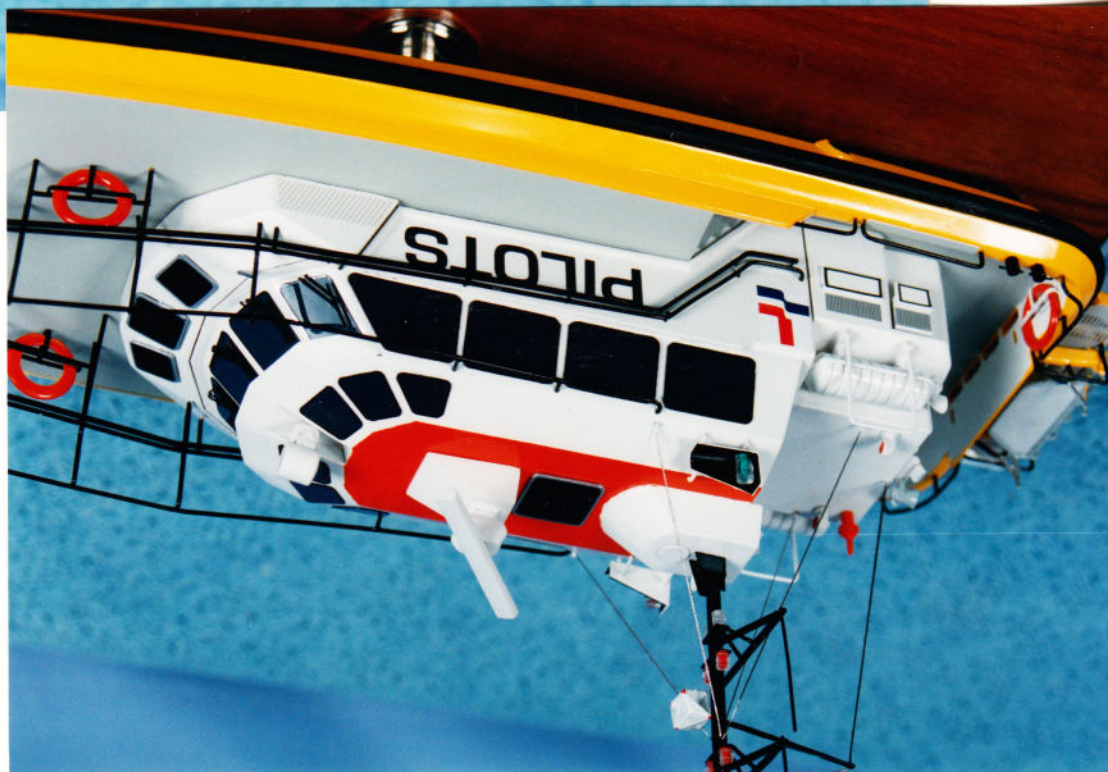
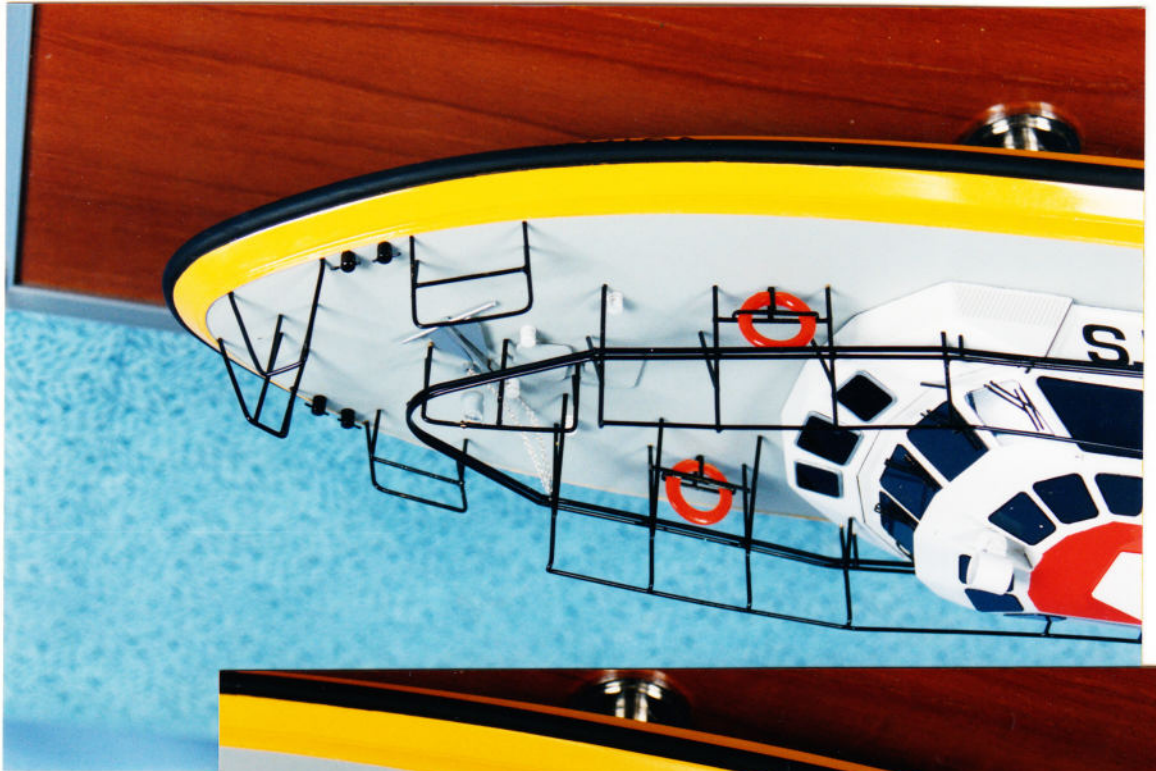
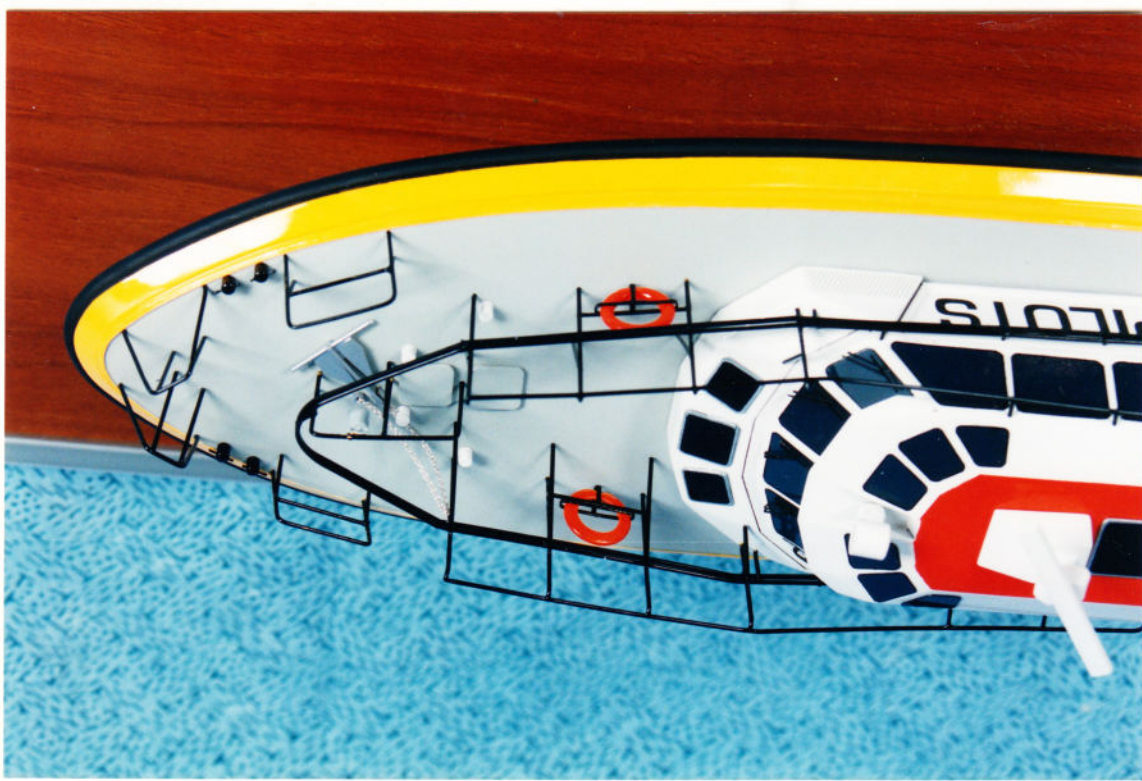



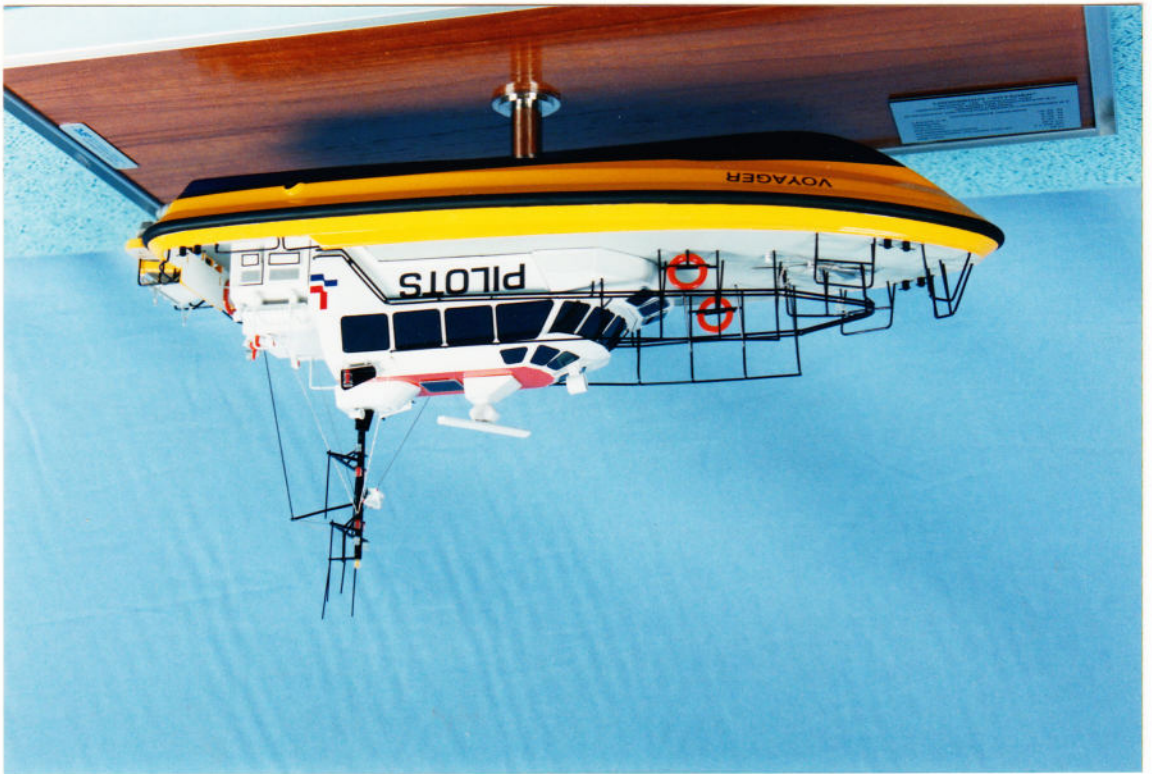



ENGELAGR
DISCOVERY
(1 voor E.
1 voor ons)
1:50

tot. 170 mm.
12/5/98



